

PFAFF

145

545

Teileliste

Parts list

Liste de pièces

Lista de piezas

Die Inhaltsübersicht auf Seite 3 gibt einen Überblick über die Aufgliederung der Liste.
Die Teile sind so abgebildet, wie sie in der Maschine funktionsmäßig zusammengehören.
Die gestrichelten Abbildungen zeigen, wo die daneben abgebildeten Teile hingehören.
Die Einrahmungen auf den Bildseiten zeigen, aus welchen Einzelteilen sich die Gruppenteile zusammensetzen.
Nähwerkzeuge und Apparate sind der separaten Unterklassen-Ausstattung zu entnehmen.
Die auf den Bildseiten verwendeten Schlüsselzeichen (□ ; ② ; ③ usw.) sind in Register „O“ zusammengefaßt und erläutert.
Das Erstellungsdatum ist auf den einzelnen Seiten oben rechts angegeben. Bei Austausch bitte Datum beachten.
Ergänzungen und Änderungen werden durch den Änderungsdienst bekanntgegeben.
Konstruktionsänderungen vorbehalten.

For the various sections of this catalogue, please refer to the "Contents" on page 3.
The parts are illustrated as they belong together in the machine.
The dashed illustrations show where the adjacent parts belong.
The framed-in sections on the illustration pages show the individual parts comprising a group.
For sewing parts and attachments please refer to the separate subclass listing.
The reference keys (□ , ② , ③ etc.) used on the illustration pages are compiled and explained in section "O".
The date of preparation of the individual pages is indicated in the upper right-hand corner. Please note the new date on revised sheets.
All alterations and modifications will be announced by special circulars.
Subject to alterations in design.

La table des matières, page 3, donne un aperçu sur la subdivision de la liste.
Les pièces figurent sur l'illustration comme elles vont ensemble.
Les figures en tirets montrent le lieu de montage des pièces figurant à côté.
Les parties encadrées sur les pages à illustration représentent les pièces individuelles formant groupe.
Pour les organes de couture et les appareils, veuillez vous référer à la fiche équipement de sous-classes.
Les symboles (□ , ② , ③ etc.) utilisés sur les pages illustrées sont regroupés et expliqués au registre „O”.
La date de parution des différentes planches est indiquée dans l'angle supérieur droit. Veiller à toujours n'utiliser que les planches les plus récentes.
Les changements seront portés à votre connaissance par l'intermédiaire de notre service de mise à jour.
Sous réserve de modifications.

En la página 3, bajo el título "contenido", puede verse un resumen de la división de la "lista de piezas".
Las piezas están ilustradas como funcionan en la máquina.
Las figuras a base de líneas entrecortadas muestran dónde y cómo van montadas las piezas ilustradas al lado.
Los recuadros en las páginas ilustradas indican las piezas individuales de que se componen los grupos.
Para los órganos de costura y aparatos, véase la „Dotación de subclases”.
Los símbolos clave (□ , ② , ③ , etc.) utilizados en las páginas ilustradas se hallan recopilados y explicados en el registro „O”.
La fecha en que cada una de las páginas ha sido editada se halla indicada en la esquina derecha superior. Al reemplazar unas hojas por otras se ruega tener en cuenta la fecha.
Todo suplemento y modificación se dará a conocer a través de nuestro servicio informativo.
Salvo modificaciones técnicas.

Register Section Registre Registro		Seite Page Página
0	Erläuterungen Explanations Légende Explicaciones	5 7 9 11
1	Kopfteile Front parts Pièces de tête Piezas de la cabeza	Pfaff 145 H3 B 13
2	Armteile Arm parts Pièces de bras Piezas del brazo	Pfaff 145 H3 B 17
3	Grundplattenteile Bedplate parts Pièces du plateau fondamental Piezas de la placa-base	Pfaff 145 H3 B 20
4	Kopfteile Front parts Pièces de tête Piezas de la cabeza	Pfaff 545 H3 C; D; N; N8; N10 23
5	Armteile Arm parts Pièces de bras Piezas del brazo	Pfaff 545 H3 C; D; N; N8; N10 27
6	Grundplattenteile Bedplate parts Pièces du plateau fondamental Piezas de la placa-base	Pfaff 545 H3 C; D; N; N8; N10 30
7	Ergänzungsteile Complementary parts Pièces complémentaires Piezas especiales	Pfaff 145 H1; H2 Pfaff 545 H1; H2 34
8	Ergänzungsteile Complementary parts Pièces complémentaires Piezas especiales	Pfaff 545 H4 34
9	Ausführung P Model P Modèle P Tipo P	35
10	Ergänzungsteile Complementary parts Pièces complémentaires Piezas especiales	Pfaff 145 H3-735/01 B Pfaff 545 H3-735/01 B; C; N Pfaff 545 H4-735/01 C; N 36
11	Unterklasse Subclass Sous-classe Subclase	-900/06 zur for pour la para la Pfaff 145 42
12	Unterklasse Subclass Sous-classe Subclase	-900/11 -900/16 -900/51 -900/56 48
13	Unterklasse Subclass Sous-classe Subclase	-906/03 zur for pour la para la Pfaff 545 60
14	Unterklasse Subclass Sous-classe Subclase	-910/01 61

Register Section Registre Registro				Seite Page Página
15	Unterklasse Subclass Sous-classe Subclase	-910/02		64
16	Unterklasse Subclass Sous-classe Subclase	-910/04		67
17	Unterklasse Subclass Sous-classe Subclase	-911/03		70
18	Unterklasse Subclass Sous-classe Subclase	-911/05		77
19	Unterklasse Subclass Sous-classe Subclase	-911/15 -911/35 -911/36		82
20	Unterklasse Subclass Sous-classe Subclase	-925/01 -925/02 -925/03		89 90 91
21	Unterklasse Subclass Sous-classe Subclase	-966/05	zur for pour la para la	Pfaff 545-900/.. 92
22	Zubehörteile Accessory parts Accessoires Accesorios			95
23	Motoranschlußsatz Motor connection kit Jeu de pièces à raccorder le moteur Juego de piezas de conexión del motor			98
24	Motor-Zugschalthebel Motor switch lever Lever de commande à tirette du moteur Palanca de mando por tracción para el motor			101
25	Positionsgeber Synchronizer Synchronisateur Sincronizador			102
26	Knieschalter Knee switch Interrupteur de genouillère Interruptor de rodilla		zur for pour la para la	-900/56-913/04 105
27	Keilriemenscheiben-Tabelle Table of V-belt pulleys Tableau des poulies à gorge en V Tabla de poleas para correas en „V”			106
28	Schmiermittel-Tabelle Table of lubricants Tableau des lubrifiants Tabla de lubricantes			107
29	Nummernverzeichnis Numerical index Tableau des numéros Índice numérico			108

00-000 000-00

Hauptgruppenteil, bestehend aus: Gruppenteilen oder
Gruppenteilen und Einzelteilen oder
Gruppenteilen, Einzelteilen und Einzelteilen mit Ergänzung.
(Siehe Einrahmungen auf den Bildseiten)

00-000 000-00

Gruppenteil, bestehend aus: Einzelteilen oder
Einzelteilen und Einzelteilen mit Ergänzung.
(Siehe Einrahmungen auf den Bildseiten)

00-000 000-00

Einzelteil mit Ergänzung (siehe Einrahmungen auf den Bildseiten)
z.B. Stellring mit Schrauben, Nadelstange mit Befestigungsschraube zur Nadel, usw.

00-000 000-00

Einzelteil

A

Maschinen-Ausstattung für feine Materialien.

B

Maschinen-Ausstattung für mittlere Materialien.

C

Maschinen-Ausstattung für mittelschwere Materialien.

D

Maschinen-Ausstattung für schwere Materialien.

H1

Obertransporthub 3,0 mm; Stoffdurchgang 7,0 mm.

H2

Obertransporthub 5,5 mm; Stoffdurchgang 7,0 mm.

H3

Obertransporthub 5,5 mm; Stoffdurchgang 11,0 mm.

H4

Obertransporthub 8,0 mm; Stoffdurchgang 14,0 mm.

S

Für Stoff

L

Für Leder

4,5

Stichlänge 4,5 mm

N

Stichlänge 6,0 mm

N8

Stichlänge 8,0 mm

N10

Stichlänge 10,0 mm

Unterklassenabhängig, Teilenummer siehe separate Unterklassen-Ausstattung.

O

Unterklassenzugehörigkeit siehe separate Unterklassen-Ausstattung.

0/1

Zur Fadenbremse Nr. 91-014 680-91 (siehe Seite 16 und 26)

3/1

Gesichert mit Loctite

5

Nähmuster einsenden

6

Nadeldicke und Spitzenform bei Bestellung angeben.

27/2

Eingeklammerte Zahl = Stärke in mm.

28

Sonderausführung

28/1

Sonderausführung, Fadenbremse

30

Frühere Ausführung, im Ersatzfall wieder bestellen.

30/0

Frühere Ausführung, nicht mehr im Programm.

30/1

Frühere Ausführung, ersetzt durch Nr. 11-210 168-15; 91-007 687-05; 91-013 106-45;
91-169 132-15.

30/2

Frühere Ausführung, ersetzt durch Nr. 11-210 168-15; 91-169 132-15.

30/3

Frühere Ausführung, ersetzt durch Nr. 91-000 335-15; 91-011 754-05.

30/4

Frühere Ausführung, ersetzt durch Nr. 91-008 469-01.

30/5

Frühere Ausführung, ersetzt durch Nr. 91-100 341-15; 91-100 342-15.
Kegelradgehäuse Nr. 91-010 127-90, wenn vorhanden, entfernen.

30/6

Frühere Ausführung, wird durch Fetten der Kegelräder mit Shell-Retina G, Bestellnummer siehe
Seite 107, nicht mehr gebraucht.

- 30/7** Frühere Ausführung, ersetzt durch Nr. 91-019 619-90; 91-100 341-15; 91-100 342-15.
- 30/8** Frühere Ausführung, ersetzt durch Nr. 91-019 619-90.
- 30/9** Frühere Ausführung, ersetzt durch Nr. 91-013 185-90 ; 91-018 150-05; 91-018 151-05 (siehe Seite 32).
- 30/10** Frühere Ausführung, ersetzt durch Nr. 91-013 185-90 (siehe Seite 32).
- 30/11** Frühere Ausführung, ersetzt durch Nr. 91-140 404-91.
- 30/12** Frühere Ausführung, ersetzt durch Nr. 91-107 923-91.
- 30/13** Frühere Ausführung, ersetzt durch Nr. 91-018 233-91.
- 30/14** Frühere Ausführung, ersetzt durch Nr. 91-107 930-91 .
- 30/15** Frühere Ausführung, ersetzt durch Nr. 91-018 235-91 .
- 30/16** Frühere Ausführung, ersetzt durch Nr. 11-130 407-15; 91-001 734-15; 91-009 599-05.
- 30/17** Frühere Ausführung, ersetzt durch Nr. 91-018 173-90 , siehe Seite 92.
- 32** Beim Einbau dieses Teils wird für die Paßgenauigkeit zum Anschlußteil keine Garantie übernommen; zweckmäßig vollständiges Aggregat bestellen.
- 32/1** Zweckmäßig Nr. 91-107 947-91 bestellen.
- 32/2** Zweckmäßig Nr. 91-018 286-91 bestellen.
- 35** Bei Montage bohren und verstiften.
- 40/1** Füllen mit Shell Tellus C 22, Bestellnummer siehe Seite 107.
- 40/4** Fetten mit Shell-Retinax G, Bestellnummer siehe Seite 107.
- 40/6** Füllen mit Sewtrol EL, Bestellnummer siehe Seite 107.
- 40/7** Tränken mit Sewtrol EL, Bestellnummer siehe Seite 107.
- 40/8** Tränken mit technischem Weißöl, Bestellnummer siehe Seite 107.
- 60** Wahlweise
- 80/1** Für Schlauch mit 4 mm Innendurchmesser.
- 80/2** Für Schlauch mit 6 mm Innendurchmesser.
- 90/1** Für Wechselstrom
- 90/2** Für Drehstrom
- 90/5** Zum Anschluß von Positionsgeber Quick B/T an Steuerkasten mit 4-poliger Buchse.
- 90/6** Zum Anschluß von Positionsgeber Quick B/K an Steuerkasten mit 7-poliger Buchse.
- 90/7** Langsamnäheinrichtung abschaltbar.
- 90/9** Für Motoren mit 8-stelliger Typennummer.
- 90/10** Nur bei Bedarf
- 90/11** Für Elektronik-Stop-Motoren
- 90/12** Für Kupplungsmotoren
- 90/13** Für Hebel-Stop-Motoren
- 90/14** Zum Motorschutzschalter
- 90/15** Für Handrad-Durchmesser 75 mm
- 90/16** Für Handrad-Durchmesser 120 mm und 150 mm.
- 90/17** Verschlußstopfen zur Grundplatte
- 95/1** x-Wert = Stichlänge, bei Bestellung angeben.
- 96** Länge angeben
- 96/1** Schlauch mit 4 mm Innendurchmesser, bei Bestellung Länge angeben.
- 96/2** Schlauch mit 6 mm Innendurchmesser, bei Bestellung Länge angeben.



00-000 000-00

Assembly, consisting of: sub-assemblies or sub-assemblies and component parts or sub-assemblies, component parts and component plus complementary parts.
(See the framed-in sections on the illustration pages).

00-000 000-00

Sub-assembly, consisting of: component parts or component parts and component plus complementary parts.
(See the framed-in sections on the illustration pages).

00-000 000-00

Component part with complementary parts (see the framed-in sections on the illustration pages), e.g. collar with screws, needle bar with needle set screw, etc.

00-000 000-00

Component part

A

Model A for sewing thin and lightweight materials.

B

Model B for sewing medium-weight materials.

C

Model C for sewing medium-heavy materials.

D

Model D for sewing heavy-weight materials.

H1

Vibrating presser lift 3.0 mm; fabric clearance 7.0 mm.

H2

Vibrating presser lift 5.5 mm; fabric clearance 7.0 mm.

H3

Vibrating presser lift 5.5 mm; fabric clearance 11.0 mm.

H4

Vibrating presser lift 8.0 mm; fabric clearance 14.0 mm.

S

For fabric

L

For leather

4,5

Stitch length 4.5 mm

N

Stitch length 6.0 mm

N8

Stitch length 8.0 mm

N10

Stitch length 10.0 mm

Subclass-dependent, for part number see subclass listing.

0

To determine subclass see subclass listing.

0/1

For thread retainer No. 91-014 680-91 (see pages 16 and 26).

3/1

Secured with Loctite

5

Submit sewing sample

6

Needle size and style of point to be stated on order.

27/2

Number in parentheses = thickness in mm.

28

Special version

28/1

Special version, thread retainer.

30

Earlier version, to be re-ordered for replacement purposes.

30/0

Earlier version, no longer produced.

30/1

Earlier version, replaced by Nos. 11-210 168-15; 91-007 687-05; 91-013 106-45; 91-169 132-15.

30/2

Earlier version, replaced by Nos. 11-210 168-15; 91-169 132-15.

30/3

Earlier version, replaced by Nos. 91-000 335-15; 91-011 754-05.

30/4

Earlier version, replaced by No. 91-008 469-01.

30/5

Earlier version, replaced by Nos. 91-100 341-15; 91-100 342-15.
Remove bevel gear casing No. 91-010 127-90, if applicable.

30/6

Earlier version, no longer required because bevel gears are greased with Shell-Retimax G (for ordering number see page 107).

- 30/7** Earlier version, replaced by Nos. 91-019 619-90; 91-100 341-15; 91-100 342-15.
- 30/8** Earlier version, replaced by No. 91-019 619-90.
- 30/9** Earlier version, replaced by Nos. 91-013 185-90 ; 91-018 150-05; 91-018 151-05 (see page 32).
- 30/10** Earlier version, replaced by No. 91-013 185-90 (see page 32).
- 30/11** Earlier version, replaced by No. 91-140 404-91.
- 30/12** Earlier version, replaced by No. 91-107 923-91.
- 30/13** Earlier version, replaced by No. 91-018 233-91.
- 30/14** Earlier version, replaced by No. 91-107 930-91 .
- 30/15** Earlier version, replaced by No. 91-018 235-91 .
- 30/16** Earlier version, replaced by Nos. 11-130 407-15; 91-001 734-15; 91-009 599-05.
- 30/17** Earlier version, replaced by No. 91-018 173-90 , see page 92.
- 32** For the fitting of this part no guarantee is accepted for accuracy of tolerance with the corresponding part. It is advisable to order a complete assembly.
- 32/1** Preferably order No. 91-107 947-91.
- 32/2** Preferably order No. 91-018 286-91.
- 35** To be drilled and pinned after assembly.
- 40/1** Top up with Shell-Tellus C 22, Ordering No. see page 107.
- 40/4** Grease with Shell-Retinax G, Ordering No. see page 107.
- 40/6** Top up with Sewtrol EL, Ordering No. see page 107.
- 40/7** Soak with Sewtrol EL, Ordering No. see page 107.
- 40/8** Soak with white oil, Ordering No. see page 107.
- 60** Optional
- 80/1** For tube with 4 mm inside diameter.
- 80/2** For tube with 6 mm inside diameter.
- 90/1** For single-phase A.C.
- 90/2** For three-phase A.C.
- 90/5** For connecting Quick synchronizer B/T to control box, with 4-pin plug.
- 90/6** For connecting Quick synchronizer B/K to control box, with 7-pin plug.
- 90/7** Inching device disengageable.
- 90/9** For Motors with 8-digit model number.
- 90/10** Only if required
- 90/11** For electronic Stop motors
- 90/12** For clutch motors
- 90/13** For lever operated Stop motors
- 90/14** For motor protection switch
- 90/15** For balance wheel diameter 75 mm.
- 90/16** For balance wheel diameter 120 mm and 150 mm.
- 90/17** Plug for bedplate
- 95/1** x-suffix = Stitch length, to be stated on order.
- 96** State length
- 96/1** Tube with 4 mm inside dia.; state length on order.
- 96/2** Tube with 6 mm inside dia.; state length on order.



00-000 000-00

Groupe principal de pièces, comprenant: des groupes de pièces ou des groupes de pièces et des pièces détachées ou des groupes de pièces, des pièces détachées et des pièces détachées avec des pièces complémentaires
(Voir parties encadrées sur illustrations).

00-000 000-00

Groupe de pièces, comprenant: des pièces détachées ou des pièces détachées et des pièces détachées avec pièces complémentaires
(Voir parties encadrées sur illustrations).

00-000 000-00

Pièce détachée avec pièces complémentaires (Voir parties encadrées sur illustrations).
Par exemple, bague avec vis, barre à aiguille avec vis de fixation d'aiguille, etc.

00-000 000-00

Pièce détachée

A

Modèle A pour la couture de matières fines et légères.

B

Modèle B pour la couture de matières moyennes.

C

Modèle C pour la couture de matières mi-lourdes.

D

Modèle D pour la couture de matières lourdes.

H1

Course du pied entraîneur 3,0 mm; passage sous les pieds 7,0 mm.

H2

Course du pied entraîneur 5,5 mm; passage sous les pieds 7,0 mm.

H3

Course du pied entraîneur 5,5 mm; passage sous les pieds 11,0 mm.

H4

Course du pied entraîneur 8,0 mm; passage sous les pieds 14,0 mm.

S

Pour tissu

L

Pour cuir

4,5

Longueur du point 4,5 mm

N

Longueur du point 6,0 mm

N8

Longueur du point 8,0 mm

N10

Longueur du point 10,0 mm

Fonction de la sous-classe, pour le numéro de la pièce, voir équipement de sous-classes.

0

Appartenance de sous-classe, voir équipement de sous-classes.

0/1

Pour le frein de fil n° 91-014 680-91 (voir pages 16 et 26).

3/1

Bloqué par Loctite

5

Joindre échantillons de couture.

6

Préciser la grosseur de l'aiguille et la forme de la pointe à la commande.

27/2

Chiffre entre parenthèses = épaisseur en mm.

28

Version spéciale

28/1

Version spéciale, frein de fil.

30

Ancienne version, à commander à nouveau pour échange.

30/0

Ancienne version, retirée du programme.

30/1

Ancienne version, remplacée par nos 11-210 168-15; 91-007 687-05; 91-013 106-45; 91-169 132-15.

30/2

Ancienne version, remplacée par nos 11-210 168-15; 91-169 132-15.

30/3

Ancienne version, remplacée par nos 91-000 335-15; 91-011 754-05.

30/4

Ancienne version, remplacée par n° 91-008 469-01.

30/5

Ancienne version, remplacée par nos 91-100 341-15; 91-100 342-15.
Enlever le carter n° 91-010 127-90, de l'engrenage conique, s'il existe.

- 30/6** Ancienne version, n'est plus nécessaire, les pignons coniques étant graissés par de la Shell-Retinax G (n° de commande, voir page 107).
- 30/7** Ancienne version, remplacée par nos 91-019 619-90; 91-100 341-15; 91-100 342-15.
- 30/8** Ancienne version, remplacée par n° 91-019 619-90.
- 30/9** Ancienne version, remplacée par nos 91-013 185-90 ; 91-018 150-05; 91-018 151-05 (voir page 32).
- 30/10** Ancienne version, remplacée par n° 91-013 185-90 (voir page 32).
- 30/11** Ancienne version, remplacée par n° 91-140 404-91.
- 30/12** Ancienne version, remplacée par n° 91-107 923-91.
- 30/13** Ancienne version, remplacée par n° 91-018 233-91.
- 30/14** Ancienne version, remplacée par n° 91-107 930-91.
- 30/15** Ancienne version, remplacée par n° 91-018 235-91.
- 30/16** Ancienne version, remplacée par nos 11-130 407-15; 91-001 734-15; 91-009 599-05.
- 30/17** Ancienne version, remplacée par n° 91-018 173-90 , voir page 92.
- 32** Aucune garantie ne pourra être assurée quant à la précision d'ajustage de cette pièce avec la pièce correspondante; il est indiqué de commander un mécanisme complet.
- 32/1** Commander de préférence le n° 91-107 947-91.
- 32/2** Commander de préférence le n° 91-018 286-91.
- 35** Percée et goupillée après montage.
- 40/1** Remplir de Shell-Tellus C 22, n° de commande voir page 107.
- 40/4** Graisser avec de la graisse Shell-Retinax-G: n° de commande, voir page 107.
- 40/6** Remplir de Sewtrol EL: n° de commande, voir page 107.
- 40/7** Imbiber de Sewtrol EL: n° de commande, voir page 107.
- 40/8** Imbiber d'huile blanche: n° de commande, voir page 107.
- 60** Au choix
- 80/1** Pour tuyau de 4 mm de diamètre intérieur.
- 80/2** Pour tuyau de 6 mm de diamètre intérieur.
- 90/1** Pour du courant alternatif
- 90/2** Pour du courant triphasé
- 90/5** Pour raccorder le synchronisateur Quick B/T sur la boîte de contrôle avec prise à 4 pôles.
- 90/6** Pour raccorder le synchronisateur Quick B/K sur la boîte de contrôle avec prise à 7 pôles.
- 90/7** Réducteur de vitesse débrayable.
- 90/9** Pour moteurs avec numéro de modèle à 8 chiffres.
- 90/10** Uniquement en cas de besoin.
- 90/11** Pour moteurs Stop électroniques.
- 90/12** Pour moteurs-transmetteurs.
- 90/13** Pour moteurs Stop à levier.
- 90/14** Pour contacteur-disjoncteur du moteur.
- 90/15** Pour diamètre du volant 75 mm.
- 90/16** Pour diamètres du volant 120 mm et 150 mm.
- 90/17** Bouchon pour plateau fondamental.
- 95/1** Valeur x = longueur du point, à préciser à la commande.
- 96** Préciser la longueur
- 96/1** Tuyau de 4 mm de diamètre intérieur; préciser la longueur.
- 96/2** Tuyau de 6 mm de diamètre intérieur; préciser la longueur.

00-000 000-00

Grupo principal de piezas, compuesto de: subgrupo de piezas o subgrupo de piezas y piezas individuales o subgrupo de piezas, piezas individuales y piezas complementarias (véanse los recuadros en las páginas ilustradas)

00-000 000-00

Subgrupo de piezas, compuesto de: piezas individuales o piezas individuales y piezas complementarias (véanse los recuadros en las páginas ilustradas).

00-000 000-00

Pieza individual con pieza complementaria (véanse los recuadros en las páginas ilustradas). Por ejemplo: anillo de ajuste con tornillo, barra de aguja con tornillo de fijación para la aguja, etc.

00-000 000-00

Pieza individual

- A Tipo A para materiales ligeros.
- B Tipo B para materiales semiligeros.
- C Tipo C para materiales semipesados.
- D Tipo D para materiales pesados.
- H1 Carrera T.S. 3,0 mm; paso para el material 7,0 mm.
- H2 Carrera T.S. 5,5 mm; paso para el material 7,0 mm.
- H3 Carrera T.S. 5,5 mm; paso para el material 11,0 mm.
- H4 Carrera T.S. 8,0 mm; paso para el material 14,0 mm.
- S Para tela
- L Para cuero
- 4,5 Largo de puntada 4,5 mm
- N Largo de puntada 6,0 mm
- N8 Largo de puntada 8,0 mm
- N10 Largo de puntada 10,0 mm
- Dependientes de la subclase, para el N° de pieza véase „Dotación de subclases”.
- 0 Para saber a qué subclase pertenece, véase „Dotación de subclases”.
- 0/1 Para el frenahilos N° 91-014 680-91 (véanse las páginas 16 y 26).
- 3/1 Asegurado con Loctite
- 5 Enviase muestra de costura.
- 6 Grosor de aguja y forma de la punta, indíquese en los pedidos.
- 27/2 Cifra entre paréntesis = espesor en mm.
- 28 Tipo especial
- 28/1 Tipo especial, frenahilos.
- 30 Tipo anterior, en caso de sustitución pidase de nuevo.
- 30/0 Tipo anterior, fuera de programa.
- 30/1 Tipo anterior, se sustituye por los N°s 11-210 168-15; 91-007 687-05; 91-013 106-45; 91-169 132-15.
- 30/2 Tipo anterior, se sustituye por los N°s 11-210 168-15; 91-169 132-15.
- 30/3 Tipo anterior, se sustituye por los N°s 91-000 335-15; 91-011 754-05.
- 30/4 Tipo anterior, se sustituye por el N° 91-008 469-01.
- 30/5 Tipo anterior, se sustituye por los N°s 91-100 341-15; 91-100 342-15. El cárter del engranaje cónico N° 91-010 127-90, deberá quitarse si existe.
- 30/6 Tipo anterior, no se usa más, ya que el engranaje cónico se engrasa con Shell-Retinax G (N° de pedido véase página 107).

- 30/7** Tipo anterior, se sustituye por los N^{os} 91-019 619-90; 91-100 341-15; 91-100 342-15.
- 30/8** Tipo anterior, se sustituye por el N^o 91-019 619-90.
- 30/9** Tipo anterior, se sustituye por los N^{os} 91-013 185-90 ; 91-018 150-05; 91-018 151-05 (véase página 32).
- 30/10** Tipo anterior, se sustituye por el N^o 91-013 185-90 (véase página 32).
- 30/11** Tipo anterior, se sustituye por el N^o 91-140 404-91.
- 30/12** Tipo anterior, se sustituye por el N^o 91-107 923-91.
- 30/13** Tipo anterior, se sustituye por el N^o 91-018 233-91.
- 30/14** Tipo anterior, se sustituye por el N^o 91-107 930-91 .
- 30/15** Tipo anterior, se sustituye por el N^o 91-018 235-91 .
- 30/16** Tipo anterior, se sustituye por los N^{os} 11-130 407-15; 91-001 734-15; 91-009 599-05.
- 30/17** Tipo anterior, se sustituye por el N^o 91-018 173-90 , véase página 92.
- 32** Al montar esta pieza no se asume garantía alguna en cuanto a la tolerancia y precisión de ajuste respecto a la pieza correspondiente; por esta razón se recomienda pedir el grupo completo.
- 32/1** Es conveniente pedir el N^o 91-107 947-91.
- 32/2** Es conveniente pedir el N^o 91-018 286-91.
- 35** Deberá hacerse un taladro y colocarse un pasador después del montaje.
- 40/1** Rellénese con Shell-Tellus C 22, para el N^o de pedido véase la página 107.
- 40/4** Engrase con grasa Shell-Retinax G, para el N^o de pedido véase la página 107.
- 40/6** Rellene con Sewtrol EL, para el N^o de pedido véase la página 107.
- 40/7** Empape con Sewtrol EL, para el N^o de pedido véase la página 107.
- 40/8** Empape con aceite blanco, para el N^o de pedido véase la página 107.
- 60** Opcional
- 80/1** Para tubo de plástico de 4 mm de diámetro interior.
- 80/2** Para tubo de plástico de 6 mm de diámetro interior.
- 90/1** Para corriente alterna monofásica
- 90/2** Para corriente alterna trifásica
- 90/5** Para conectar el posicionador Quick B/T a la caja de mandos con enchufe de 4 polos.
- 90/6** Para conectar el posicionador Quick B/K a la caja de mandos con enchufe de 7 polos.
- 90/7** Dispositivo para costura lenta, desconectable.
- 90/9** Para motores con número de modelo de 8 cifras.
- 90/10** Solo en caso necesario.
- 90/11** Para motores stop electrónicos.
- 90/12** Para motores de embrague.
- 90/13** Para motores stop de palanca.
- 90/14** Para el interruptor de seguridad del motor (guardamotor).
- 90/15** Para 75 mm de diámetro del volante.
- 90/16** Para 120 mm y 150 mm de diámetro del volante.
- 90/17** Tapón para la placa base.
- 95/1** Valor x = Largo de puntada, indíquese en los pedidos.
- 96** Indíquese la largura
- 96/1** Tubo flexible de 4 mm de diámetro interior; indíquese la largura en los pedidos.
- 96/2** Tubo flexible de 6 mm de diámetro interior; indíquese la largura en los pedidos.

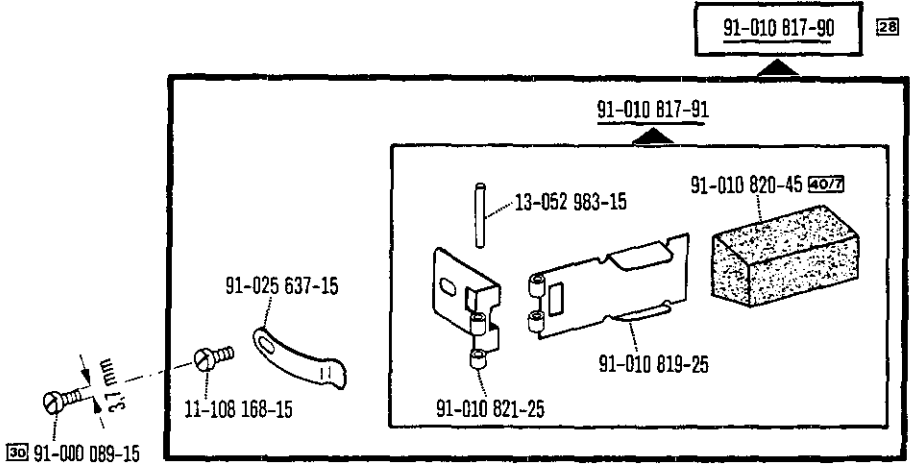
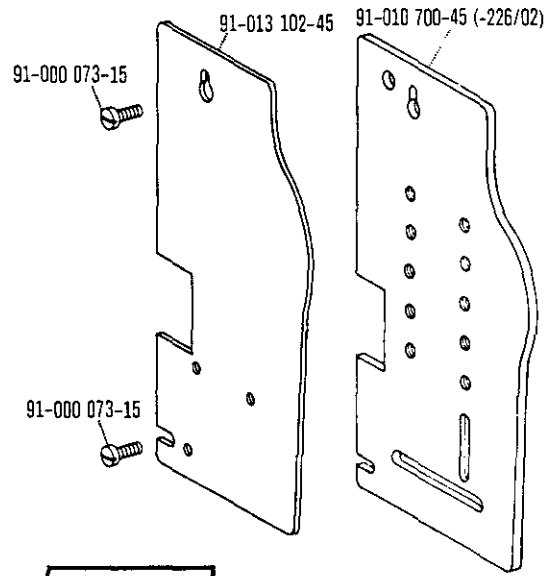
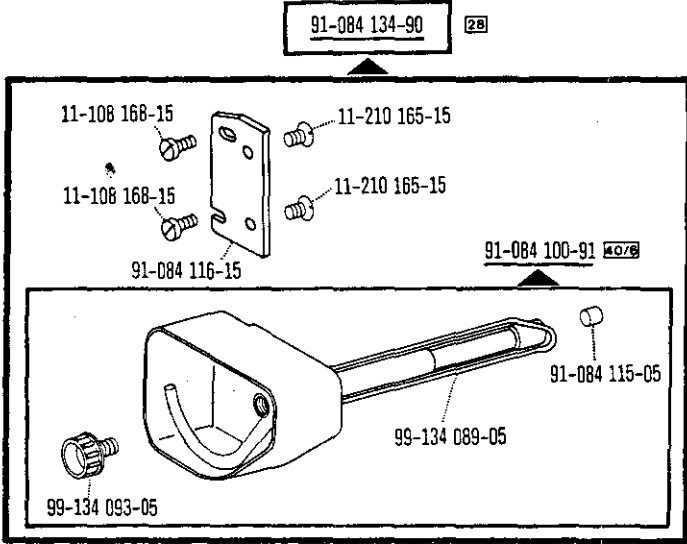
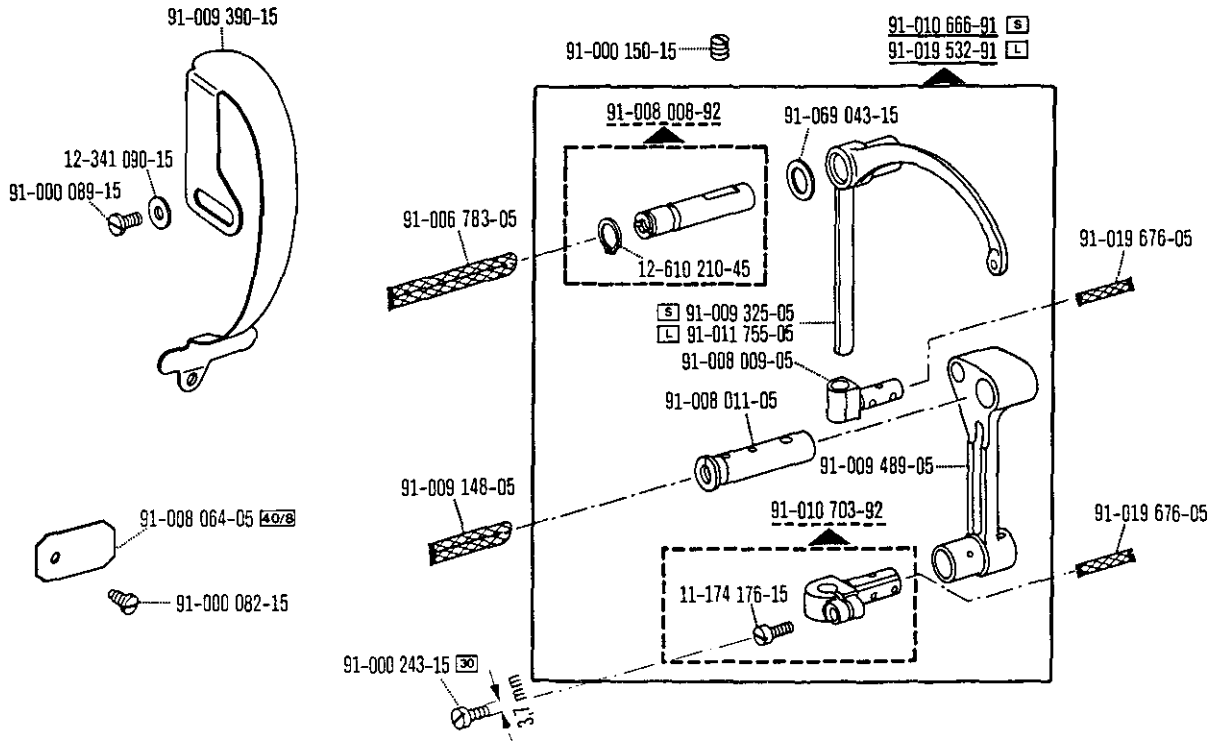

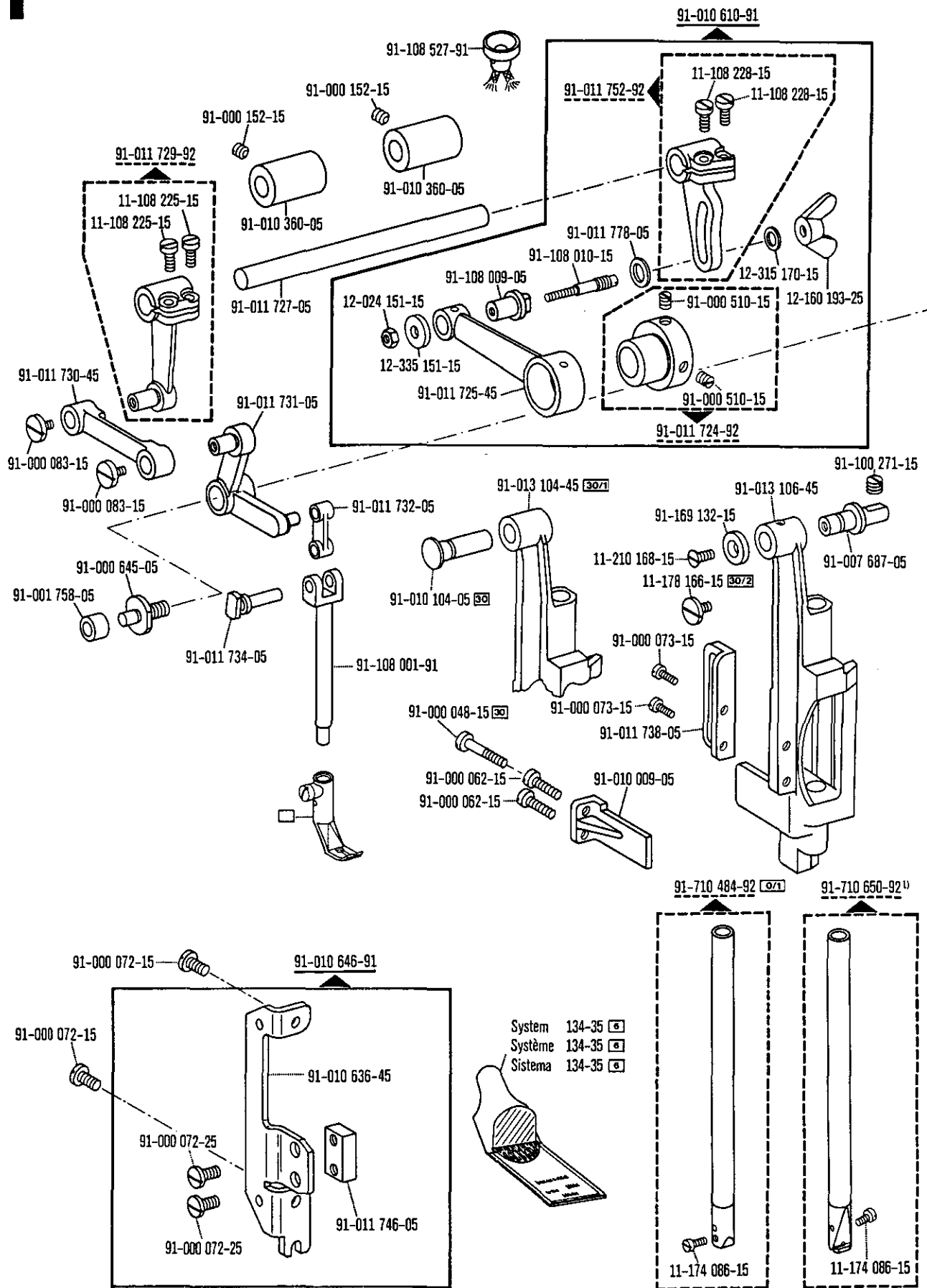

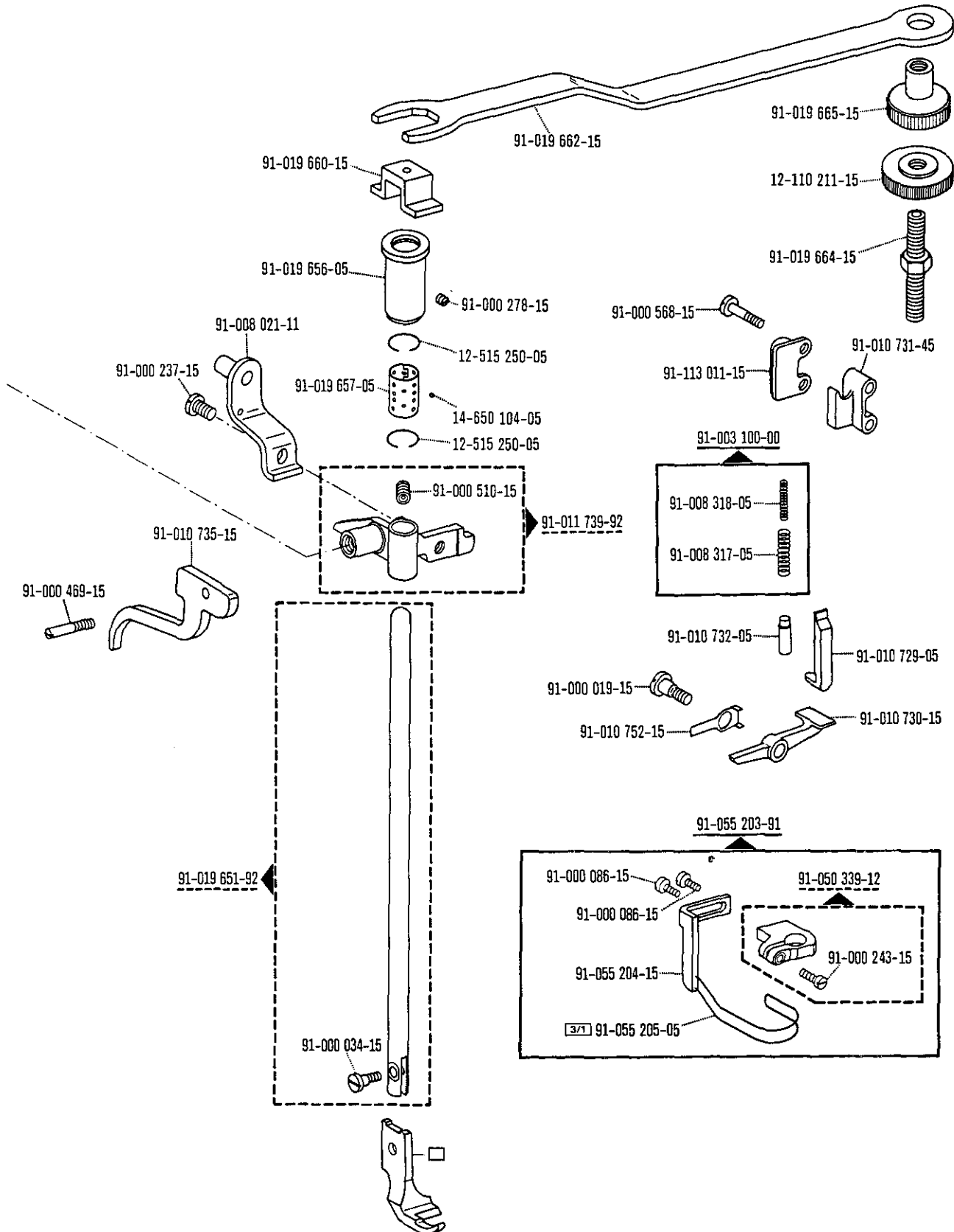

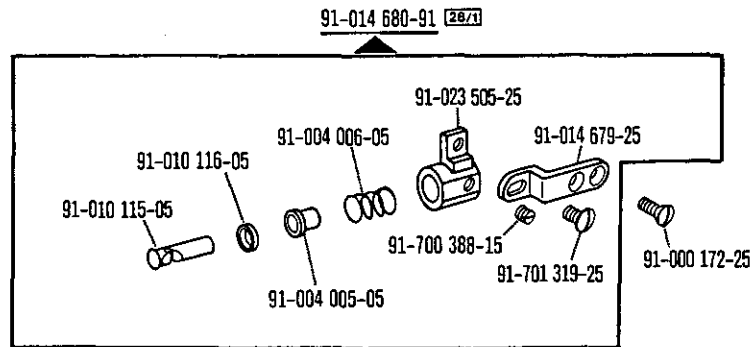
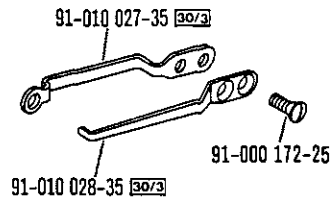
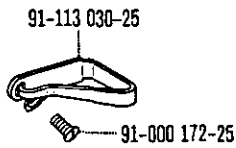
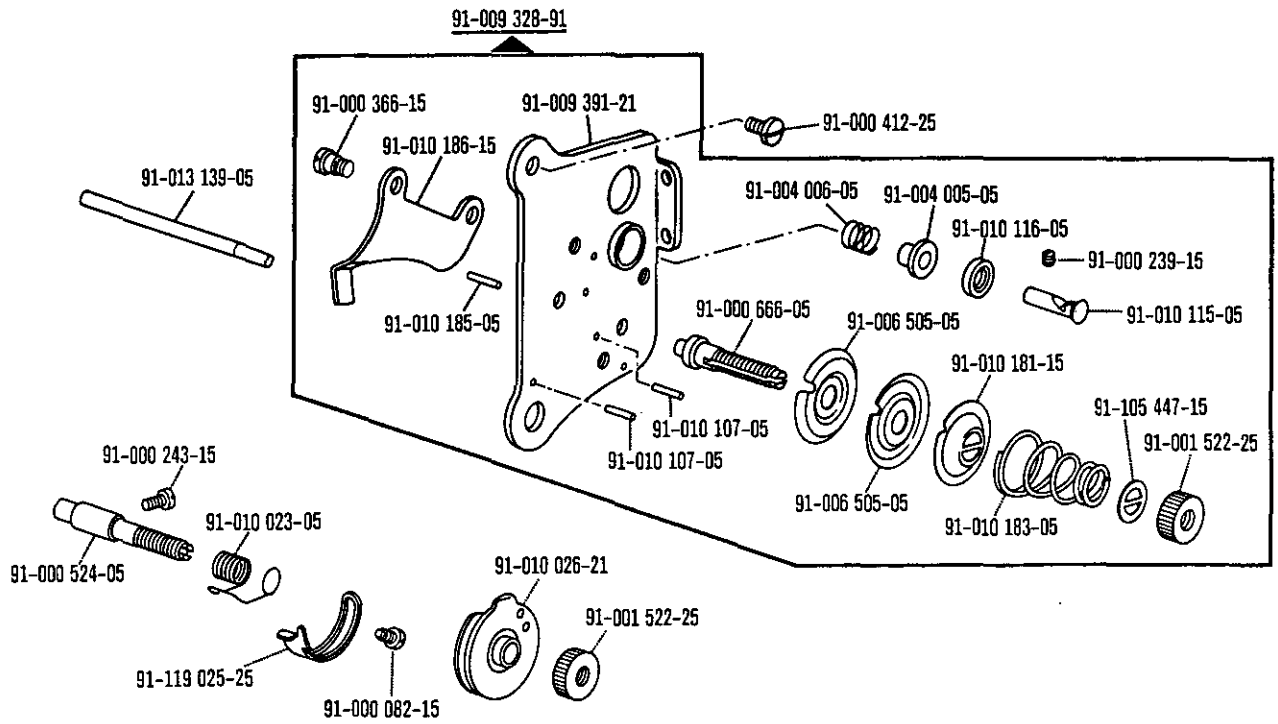

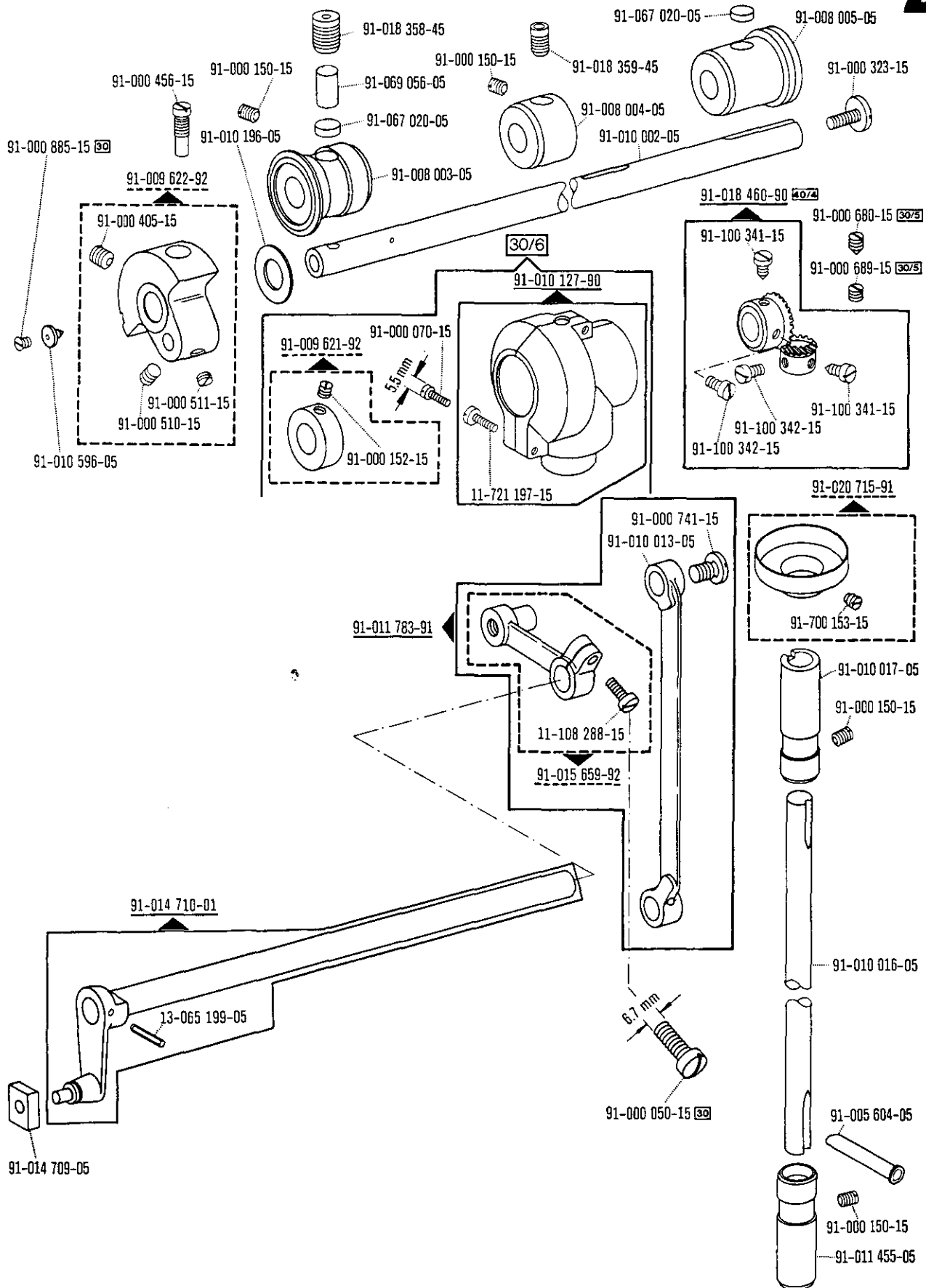

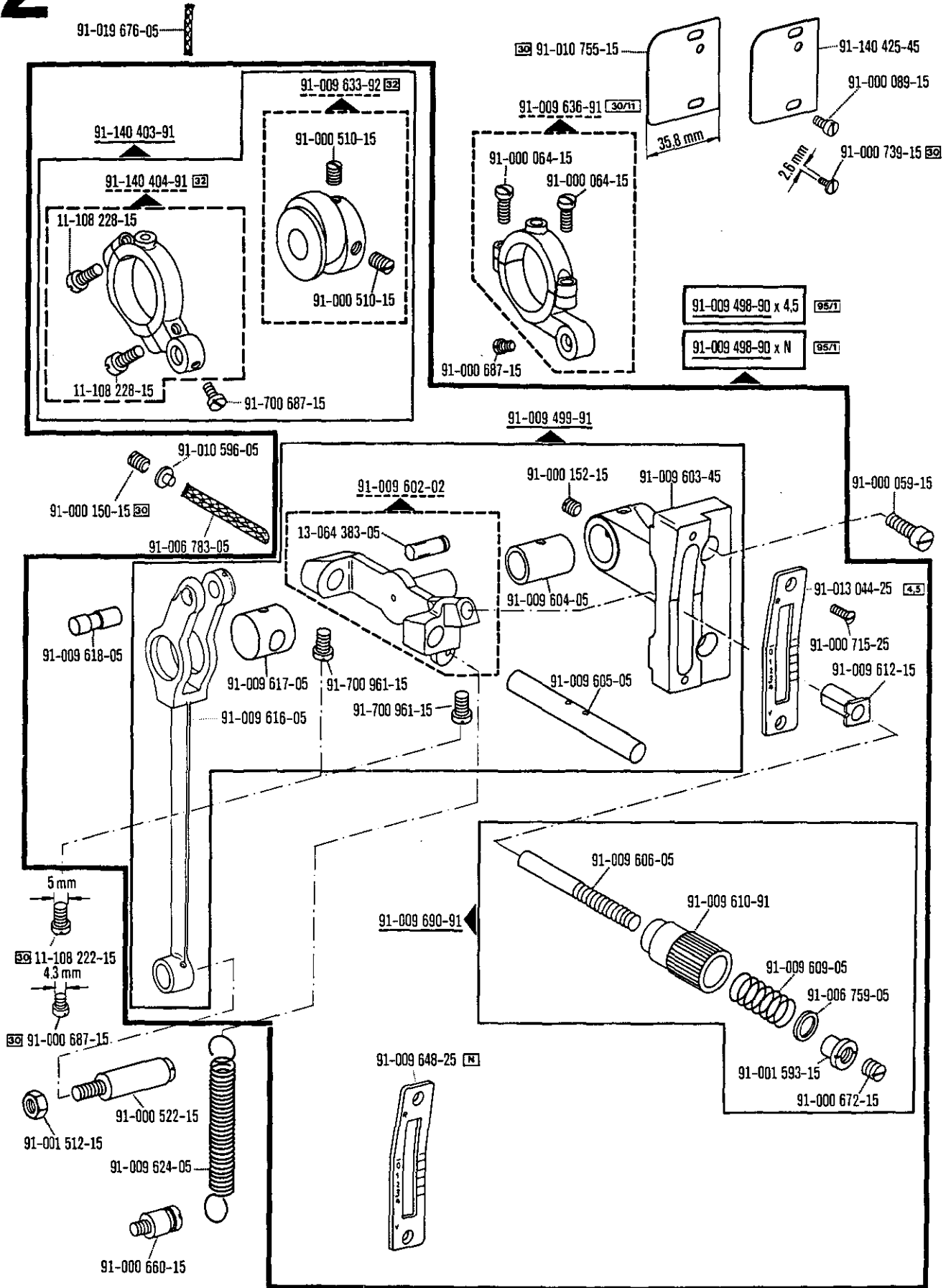

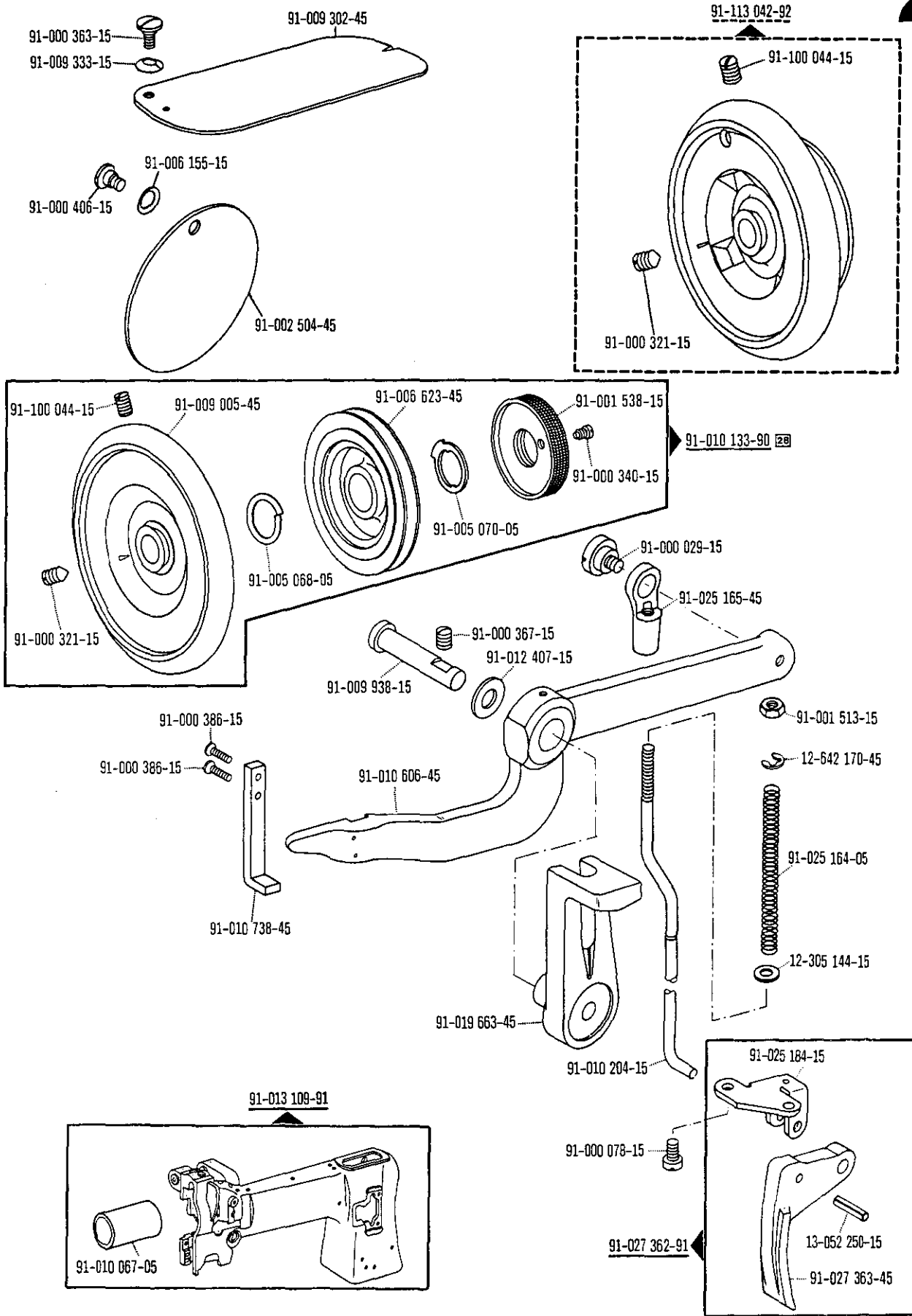

00-000 000-00 00-000 000-00 00-000 000-00 siehe Erläuterungen Seite 5
see explanations on page 7
voir légende page 9

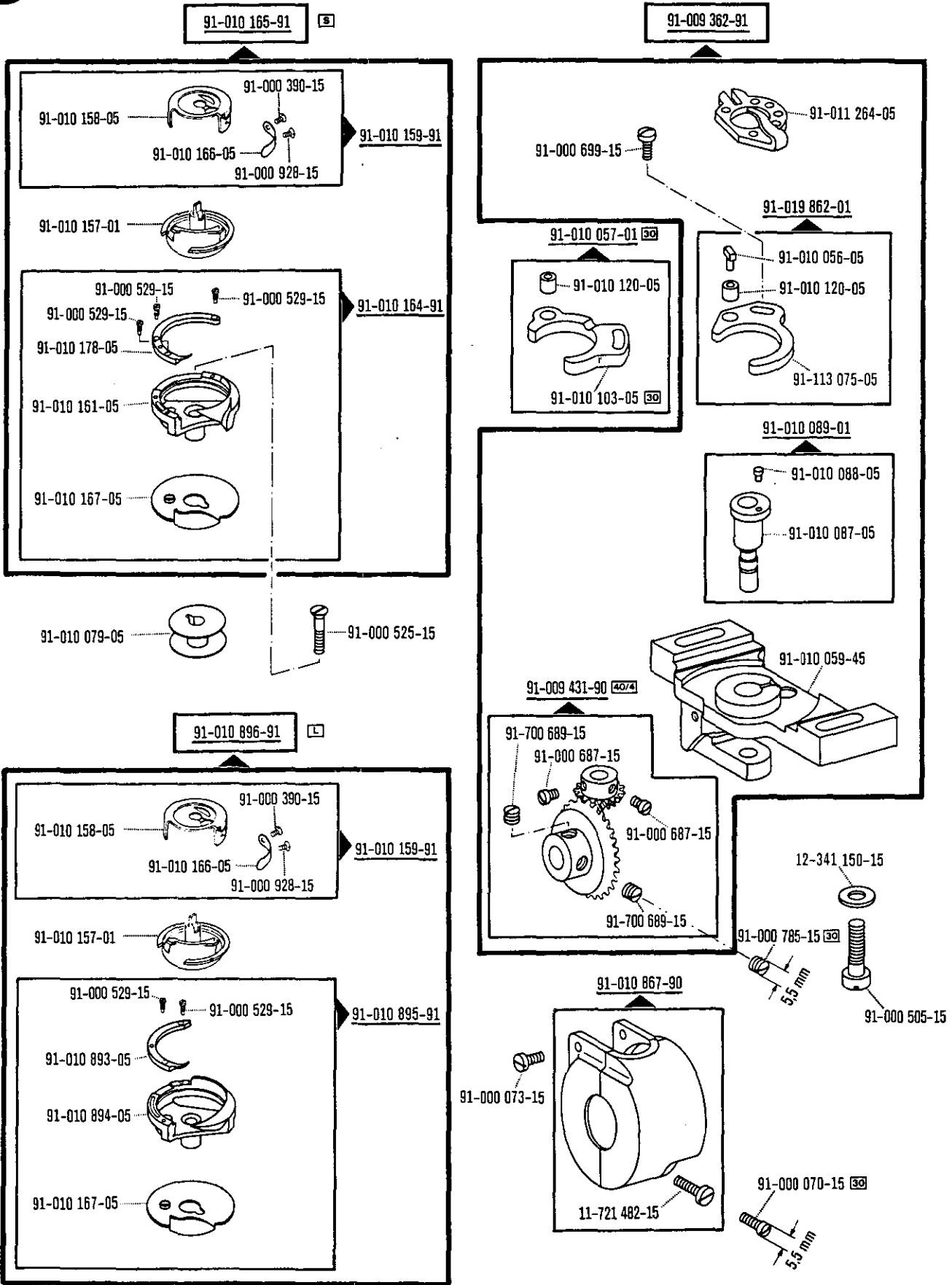

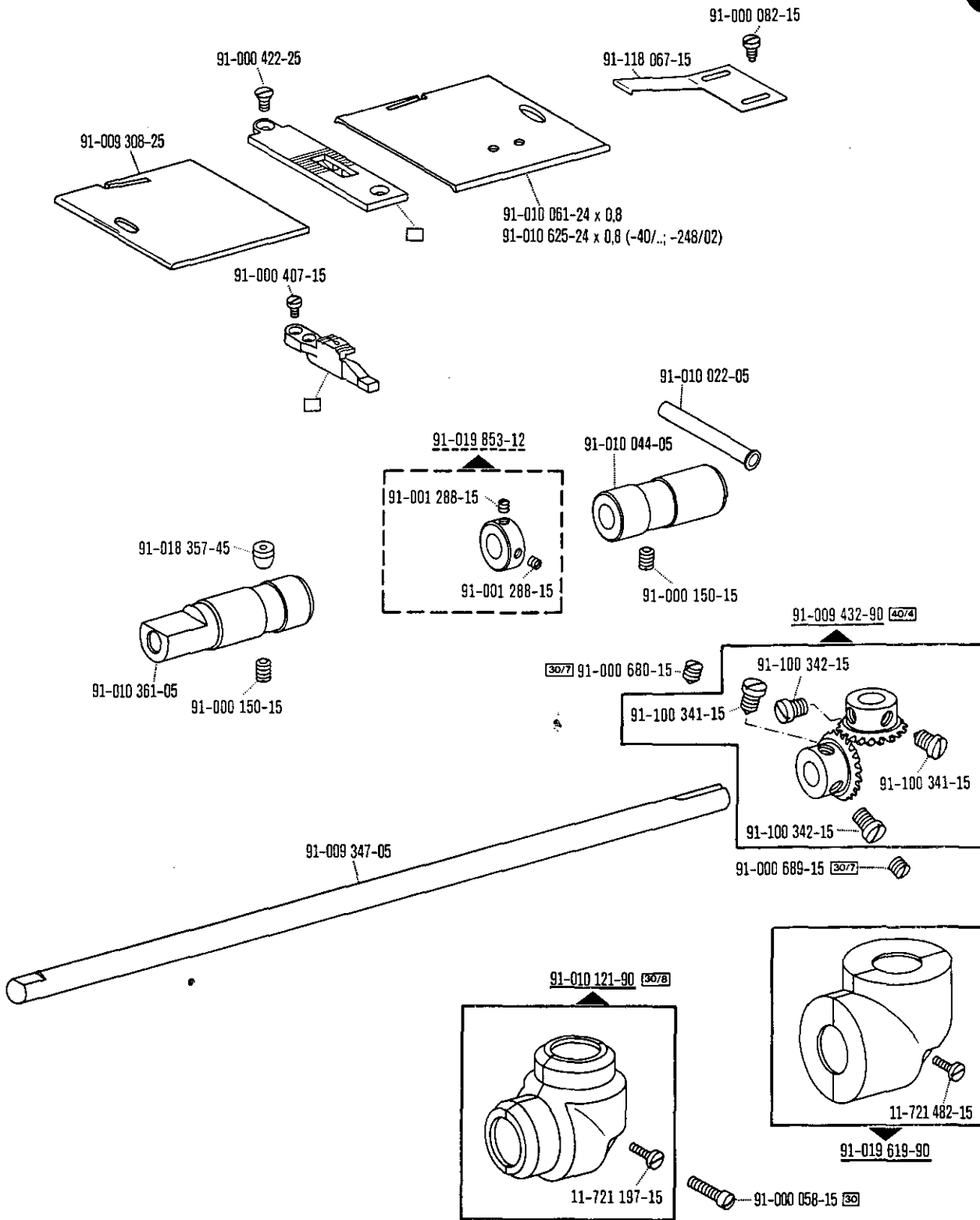

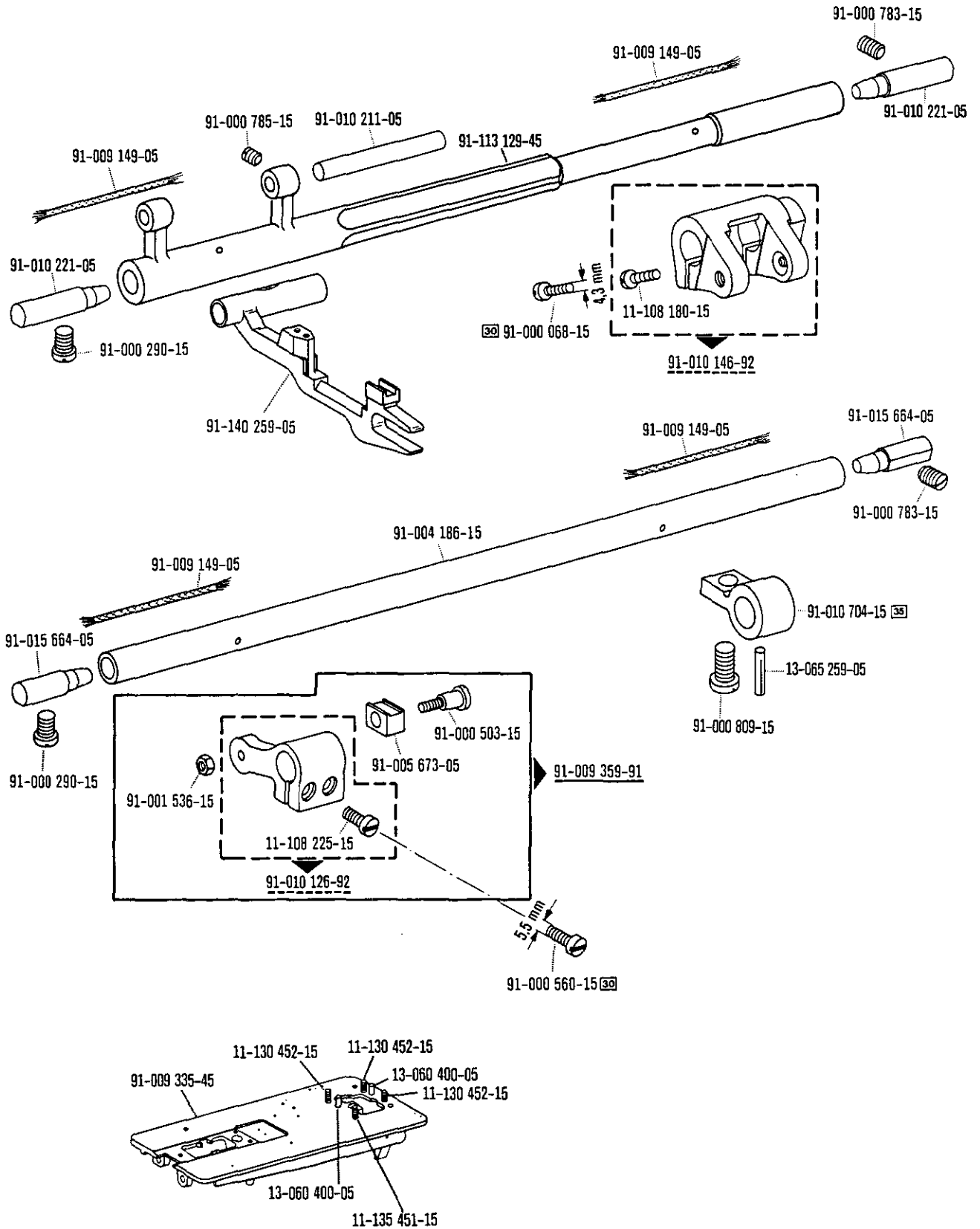

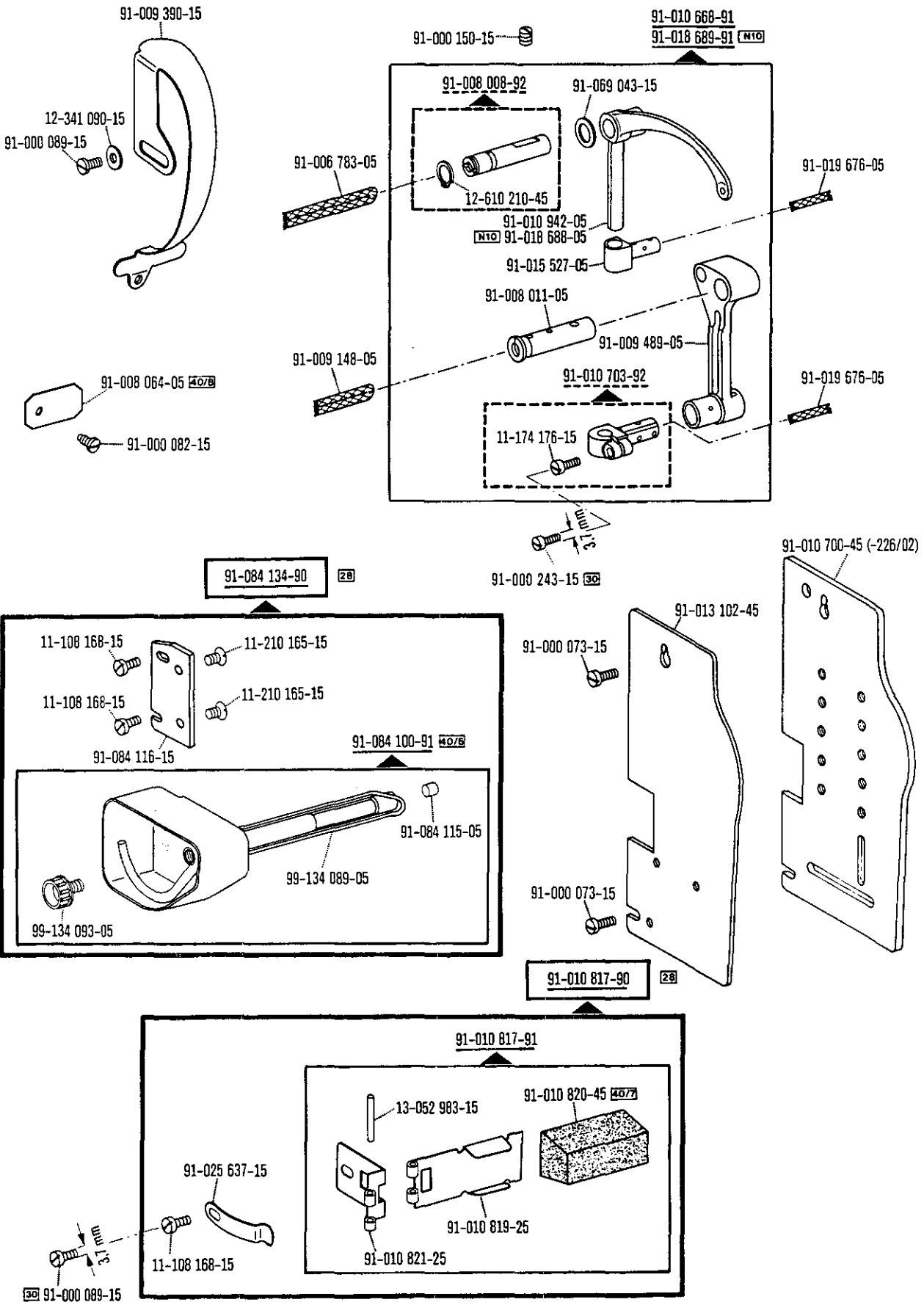

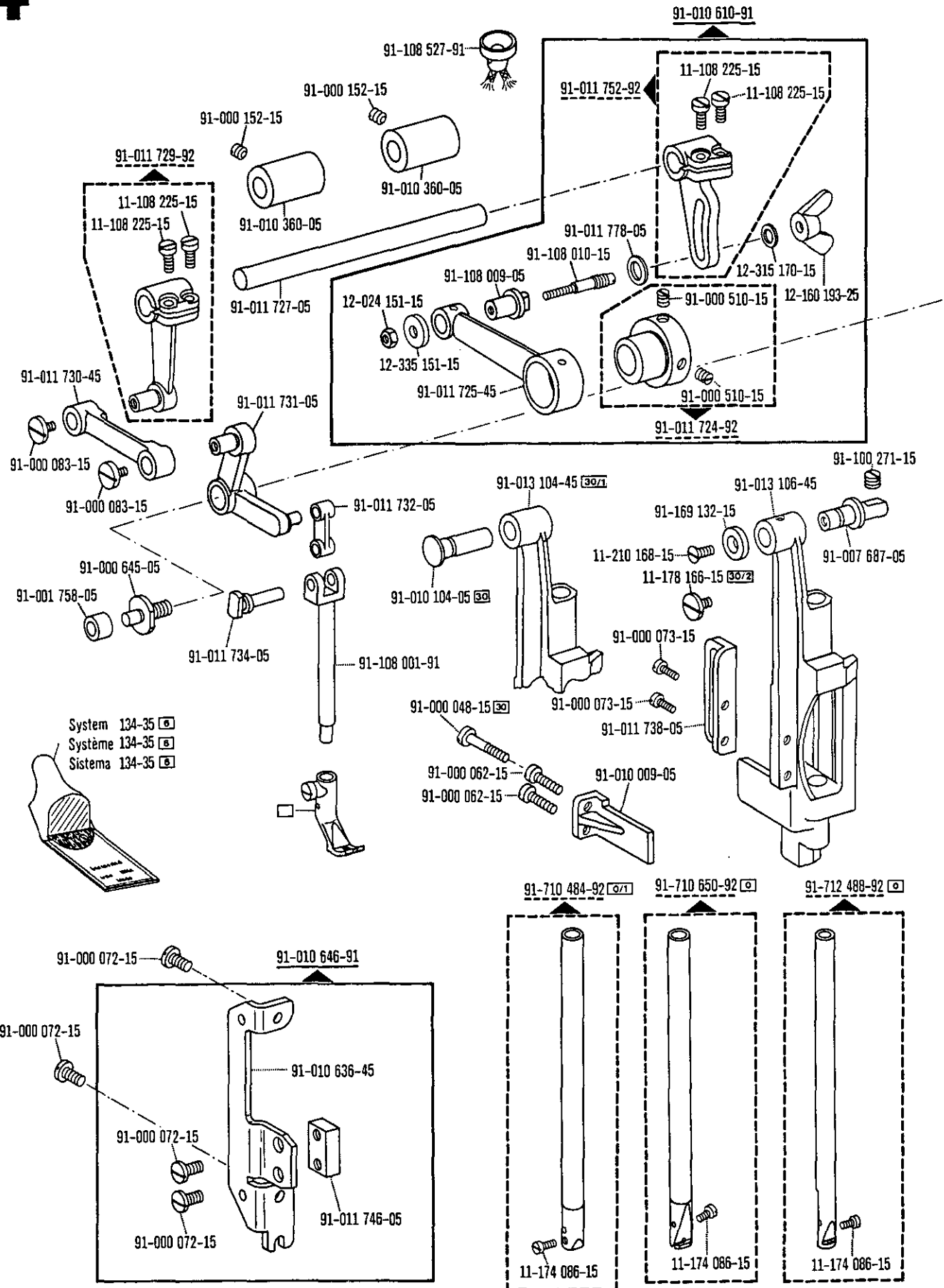

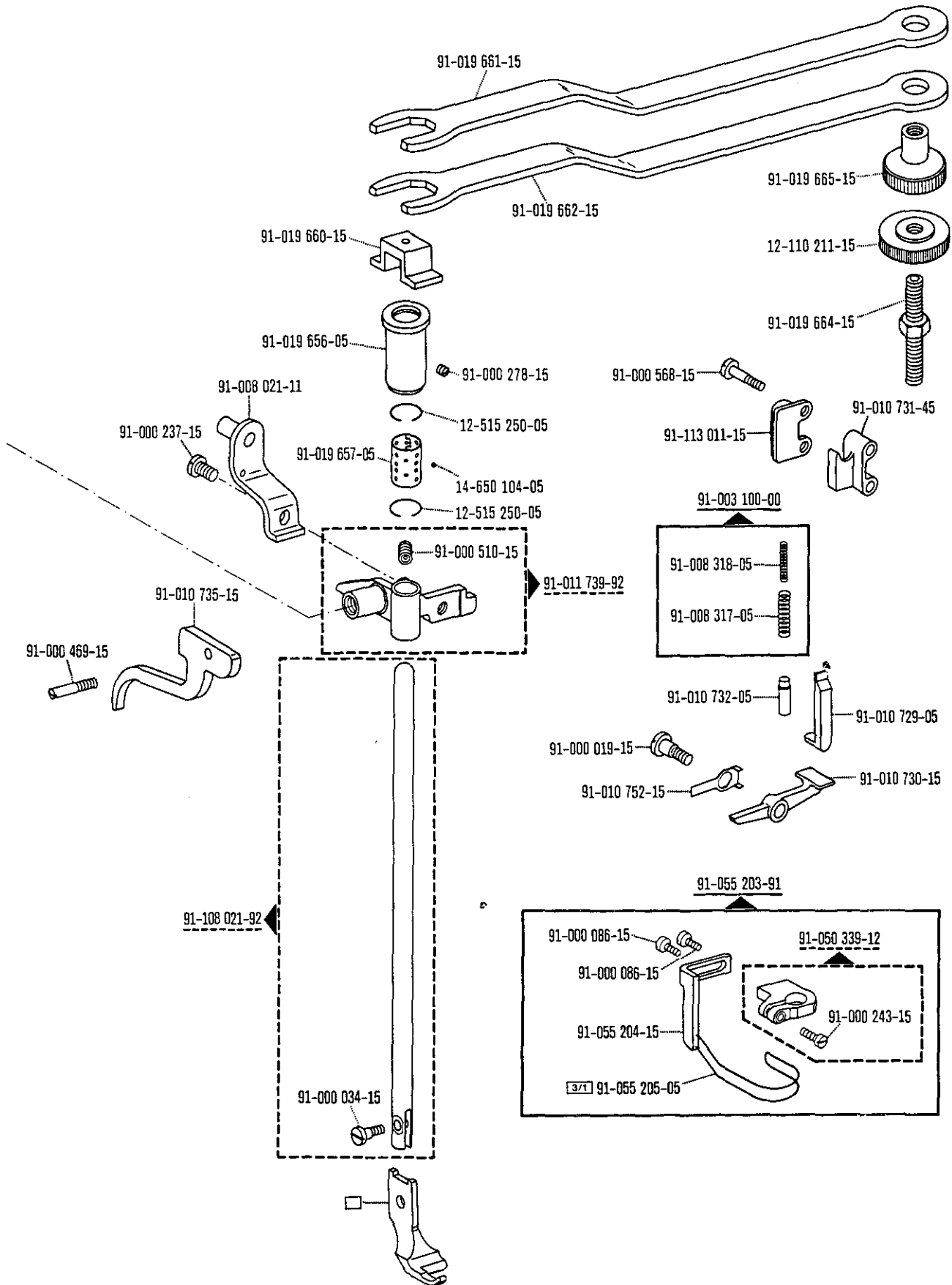

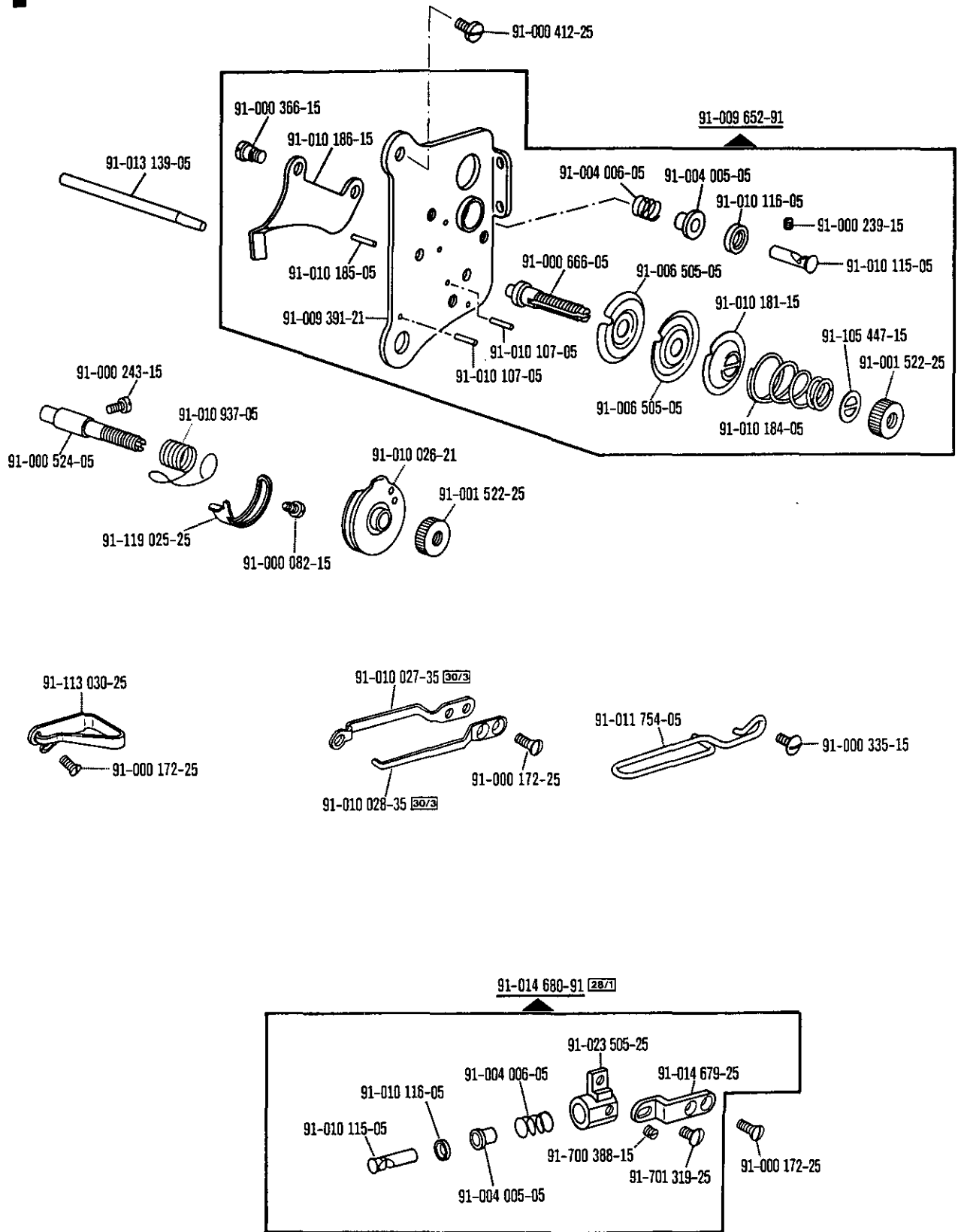

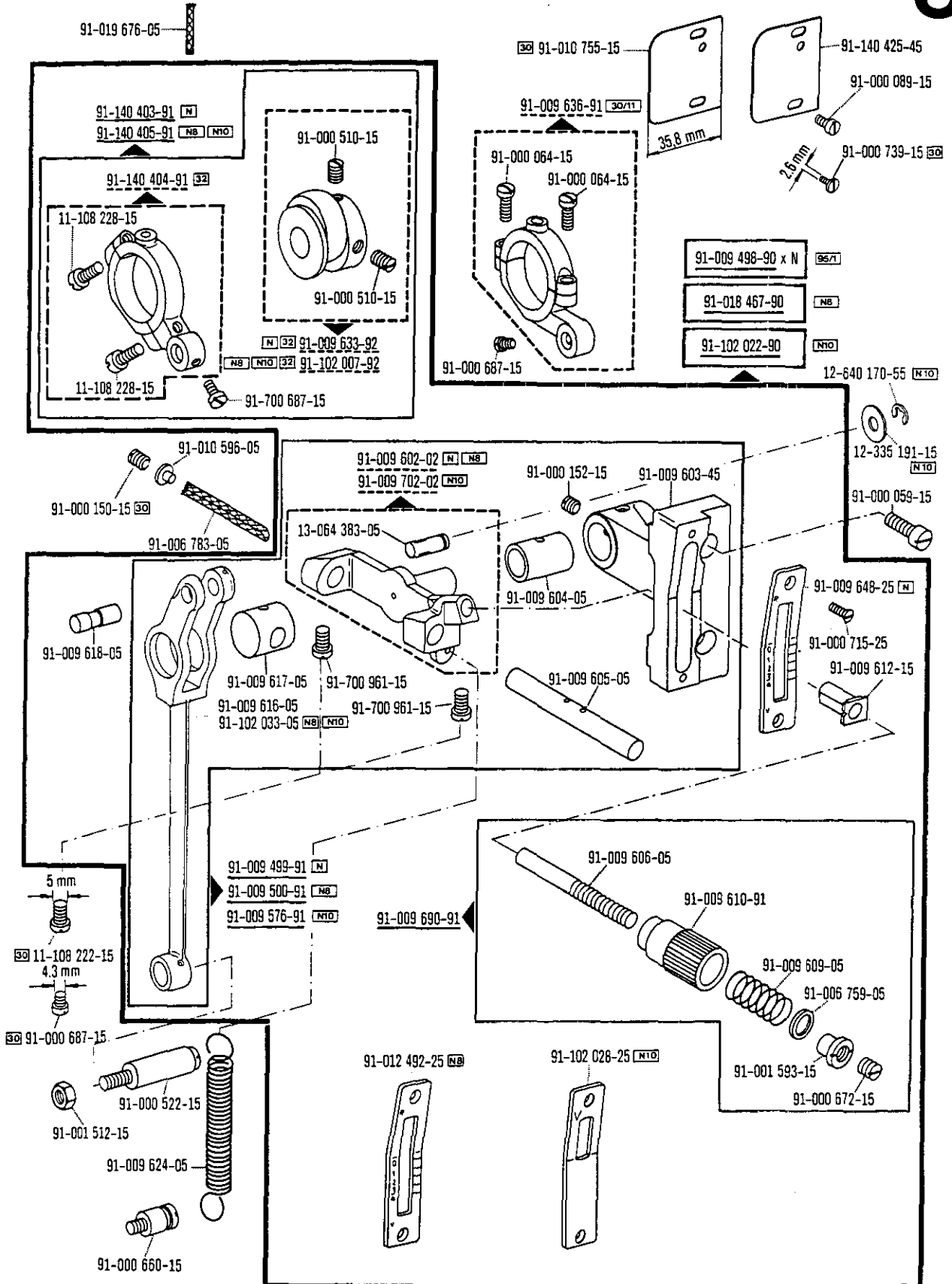

91-000 000-00 00-000 000-00 00-000 000-00 00-000 000-00 [N] [NB] [N10] [30] [30/11] [32] [95/1] siehe Erläuterungen Seite 5
 see explanations on page 7
 voir légende page 9
 ver explicaciones de la página 11

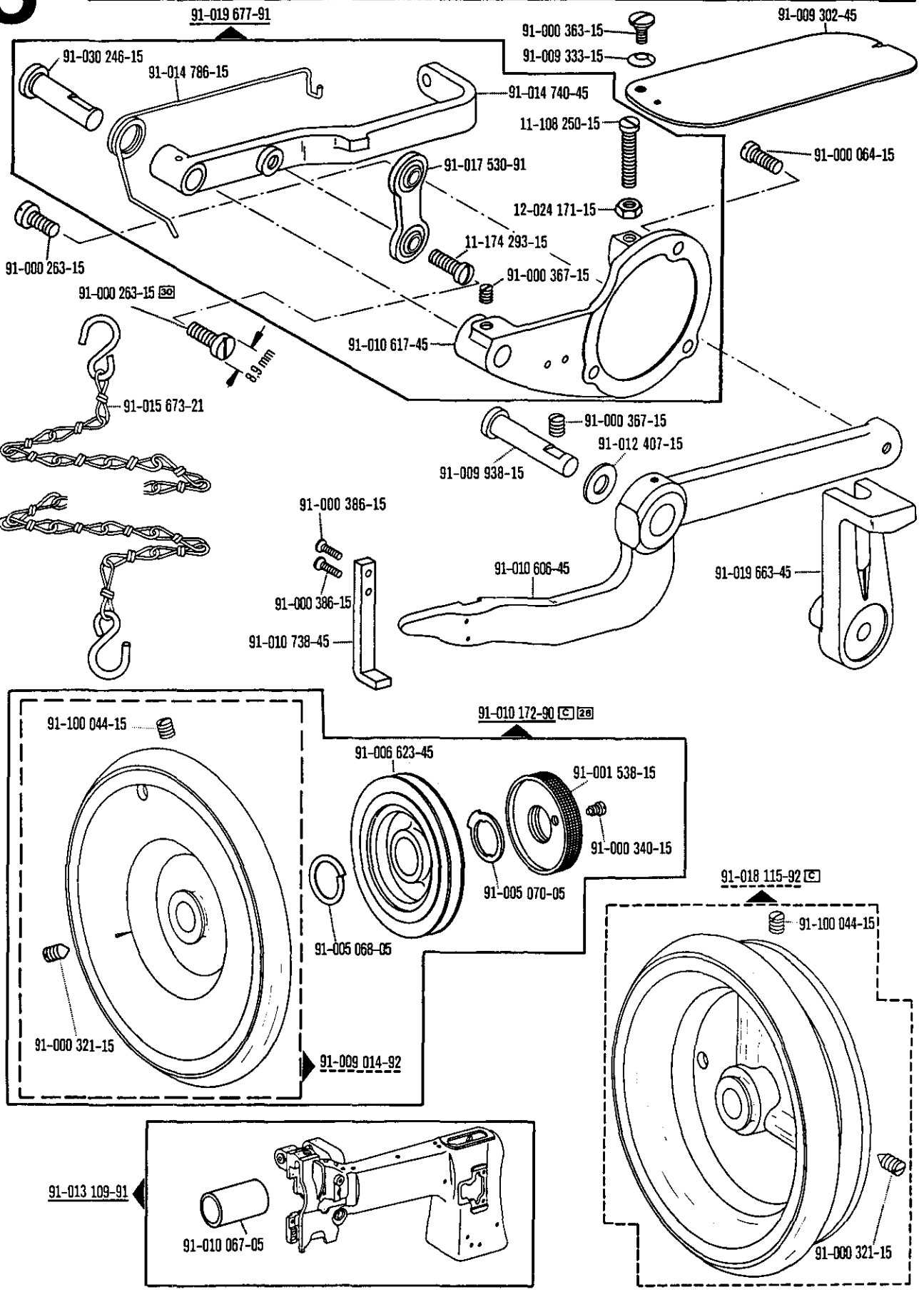

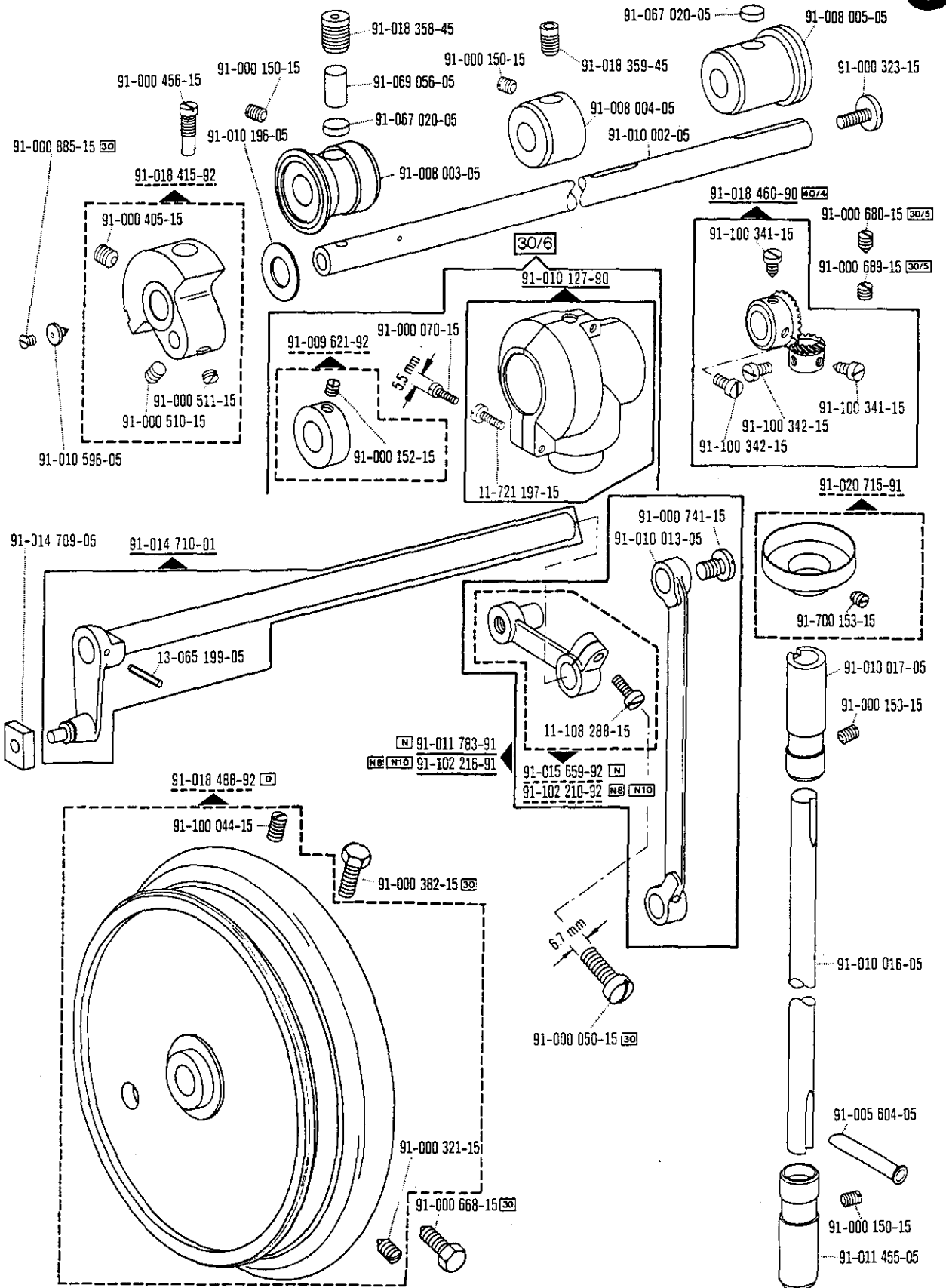

00-000 000-00 00-000 000-00 00-000 000-00 [D] [N] [NB] [N10] [30] [30/3] [30/8] [40/4] siehe Erläuterungen Seite 5
 see explanations on page 7
 voir legende page 9
 ver explicaciones de la pagina 11

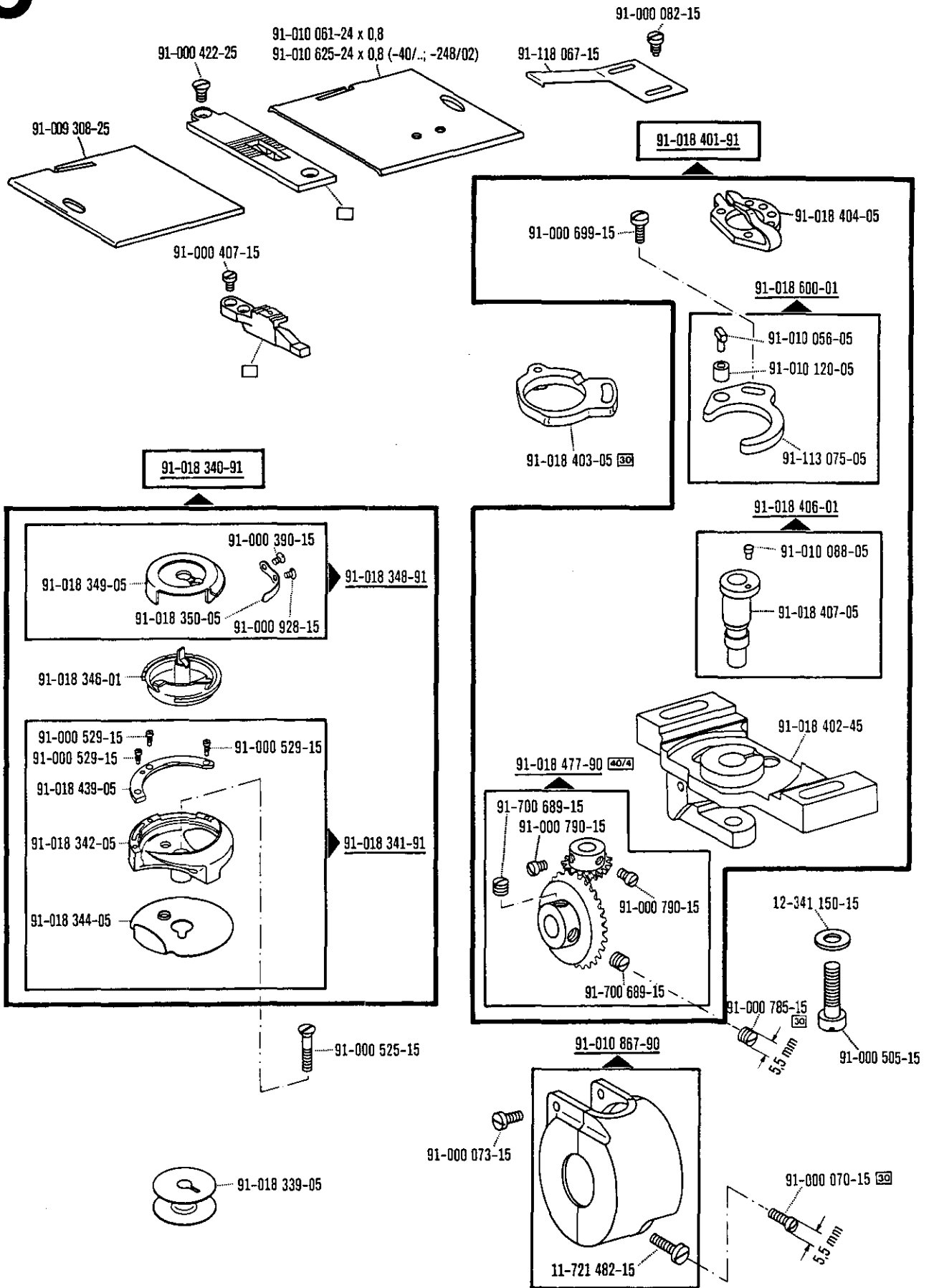

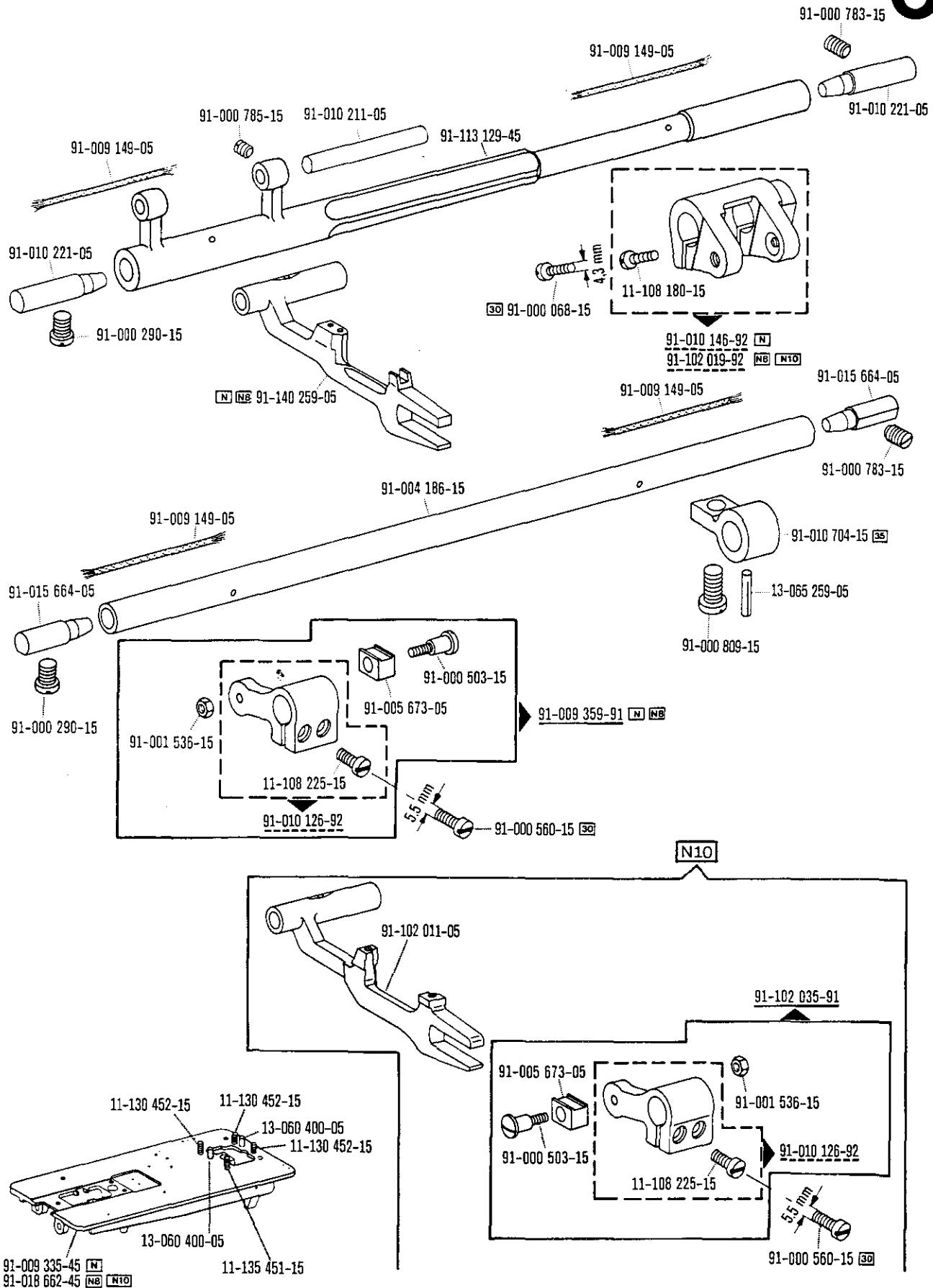

91-000 000-00 91-000 000-00 91-000 000-00 N NB N10 30 35 siehe Erläuterungen Seite 5
 see explanations on page 7
 voir legende page 9
 ver explicaciones de la página 11

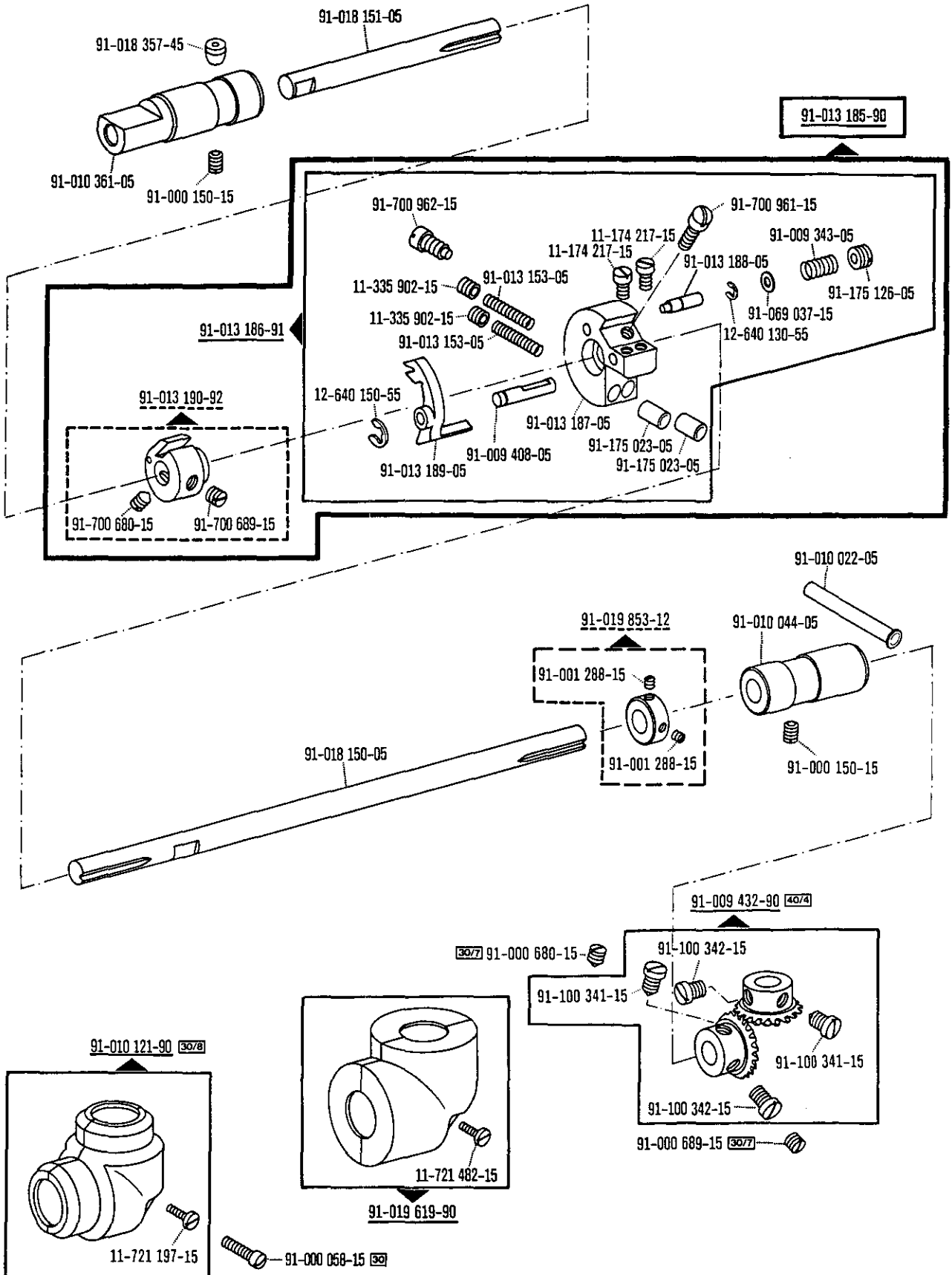

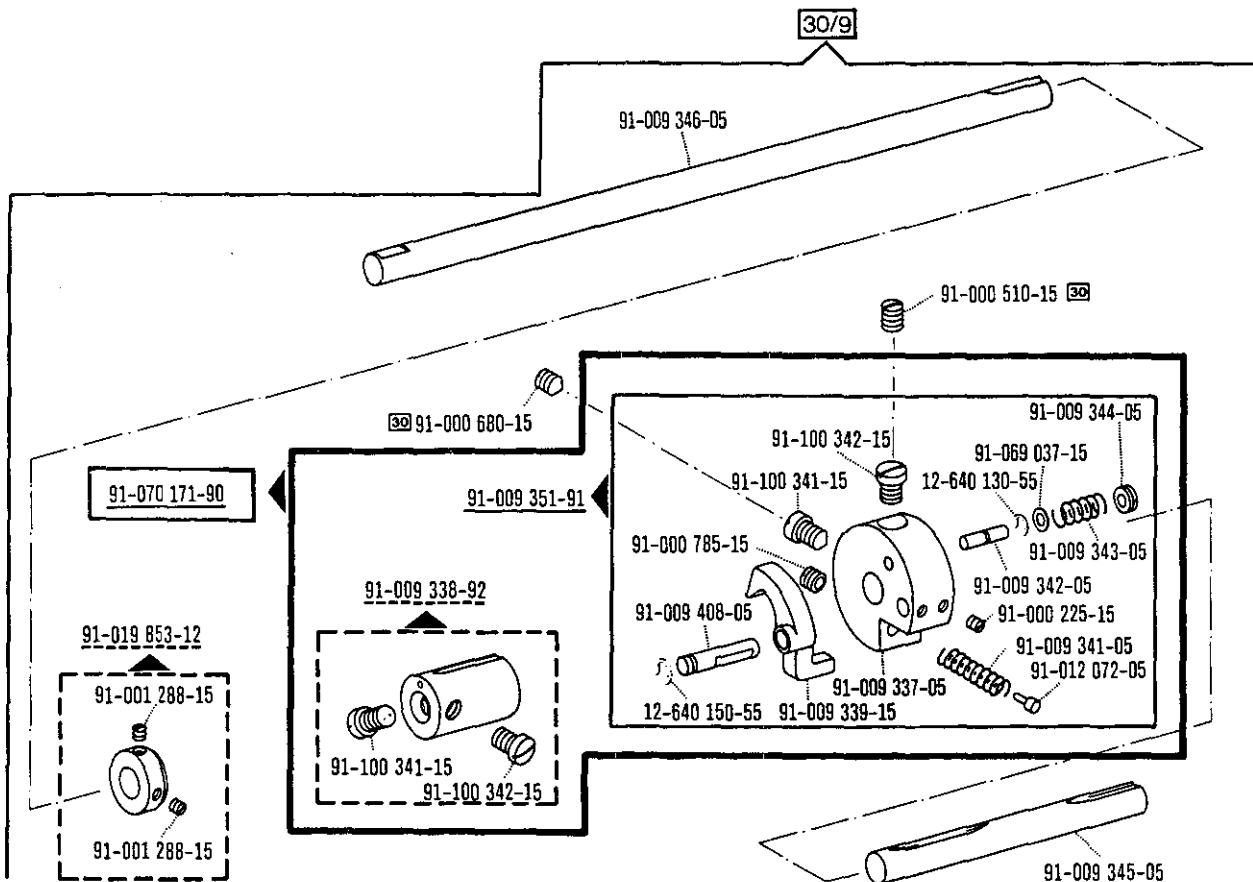
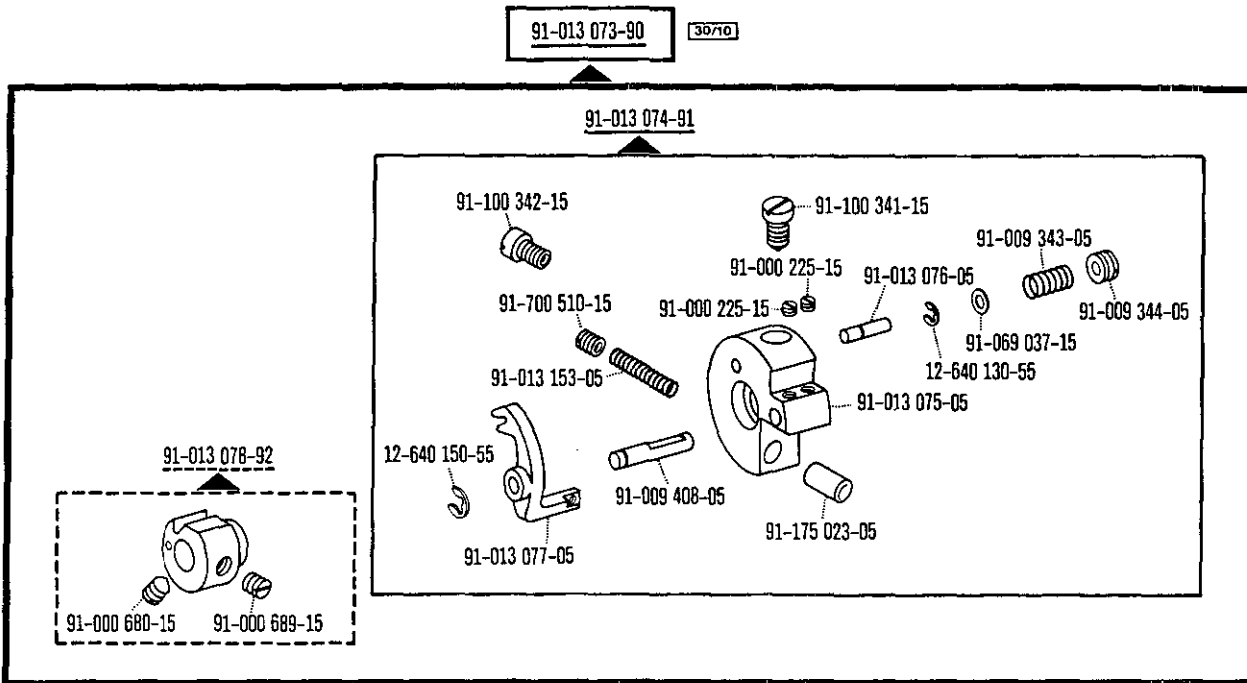

7

Pfaff 145 H1 ; **H2** (for standard parts, please refer to the Pfaff 145 H3; 545 H3)
Pfaff 545 H1 ; **H2** (las demás piezas iguales que las de la Pfaff 145 H3; 545 H3)

11.80

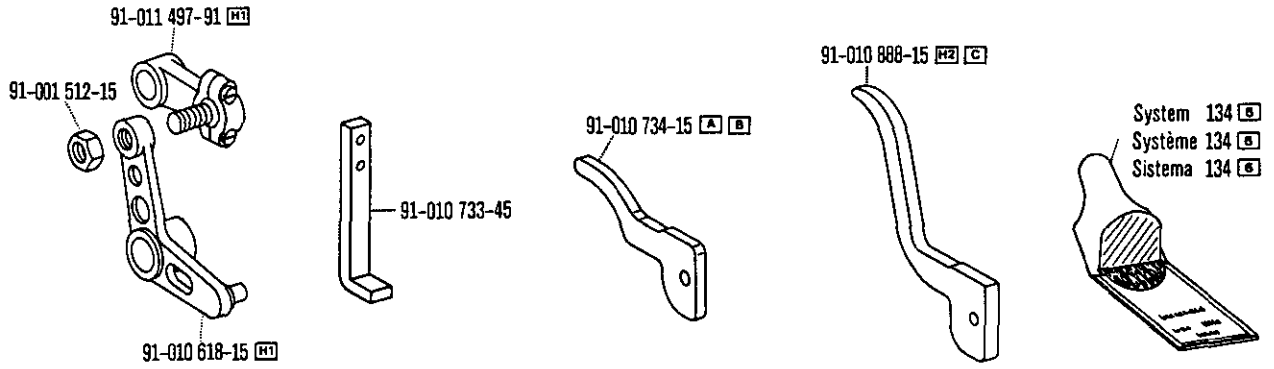

(die sonstigen Teile wie Pfaff 545 H3)
 (for standard parts, please refer to the Pfaff 545 H3)
 (les autres pièces sont les mêmes que celles de la Pfaff 545 H3)
 (las demás piezas iguales que las de la Pfaff 545 H3)

8

Pfaff 545 H4

11.80

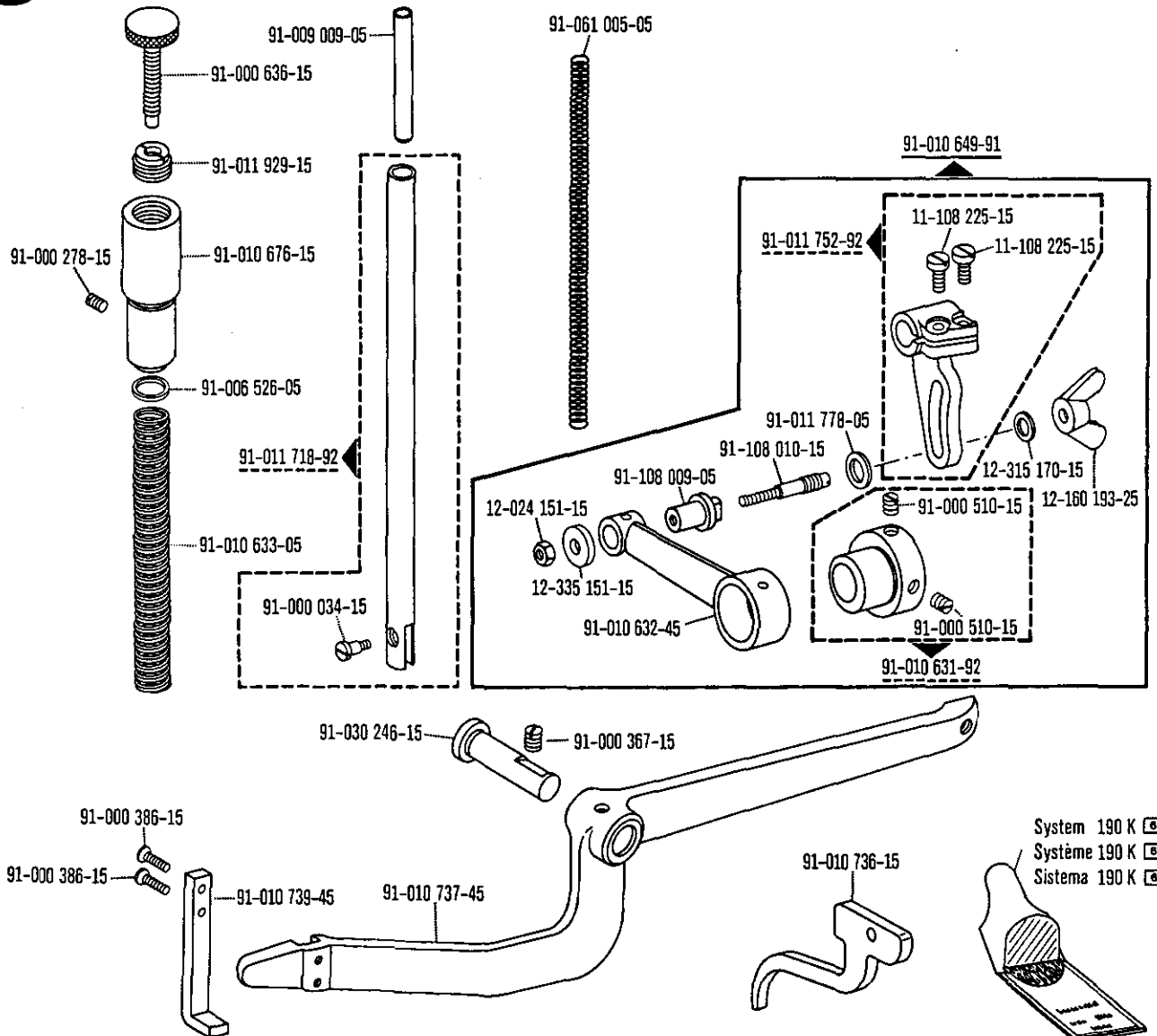

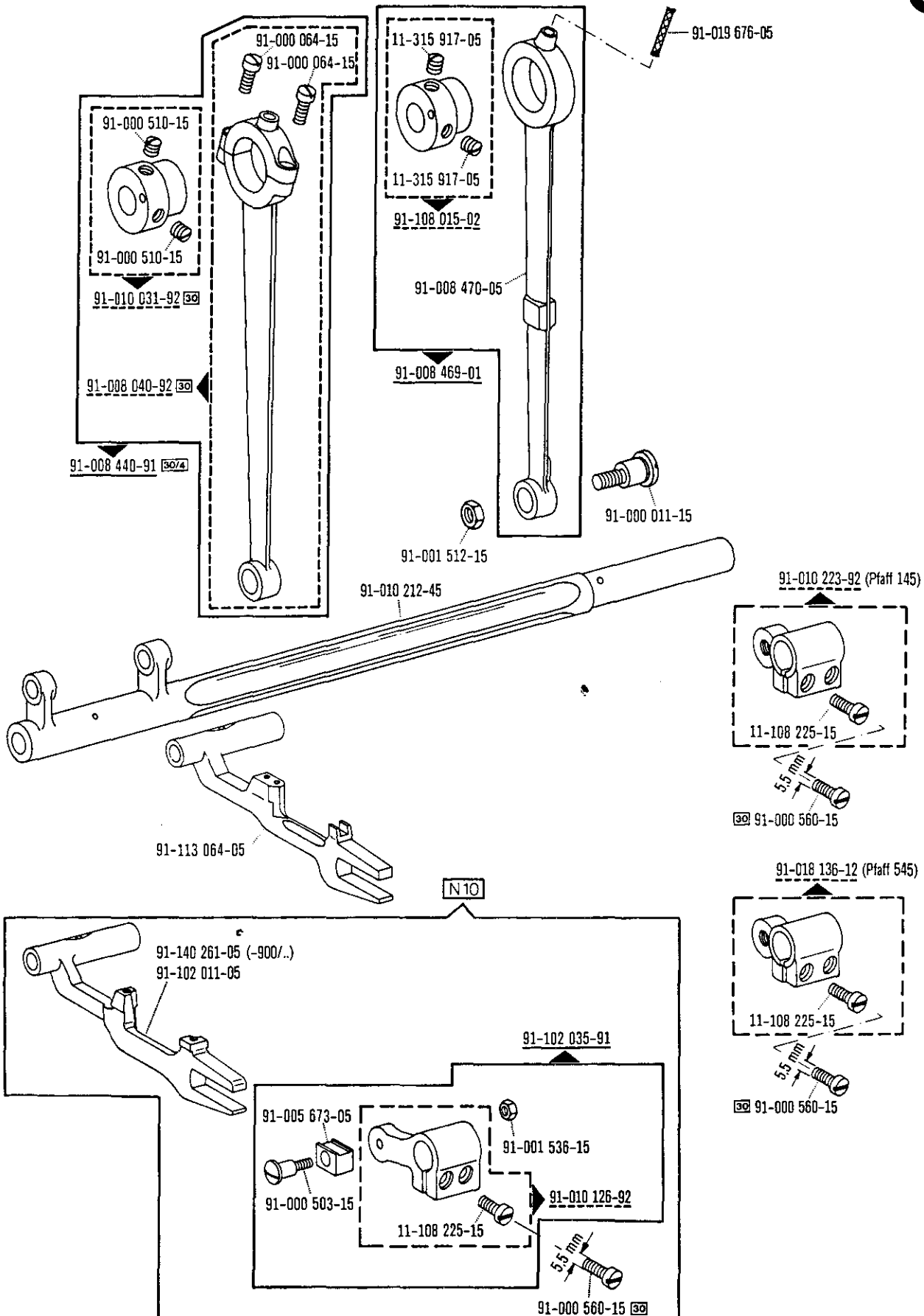

00-000 000-00 00-000 000-00 00-000 000-00 [N10] [30] [30/4] siehe Erläuterungen Seite 5
see explanations on page 7
voir légende page 9
ver explicaciones de la página 11

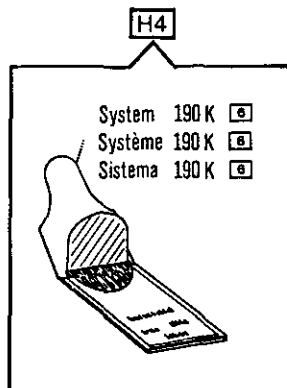
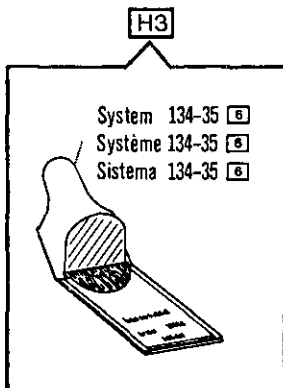
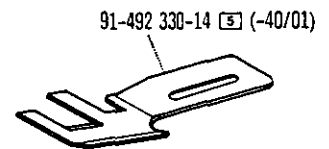
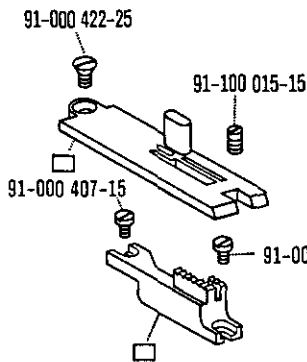
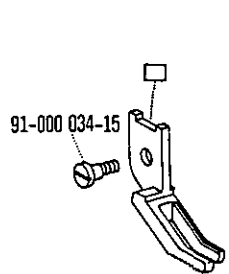
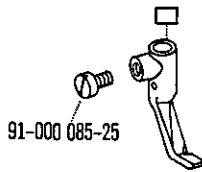
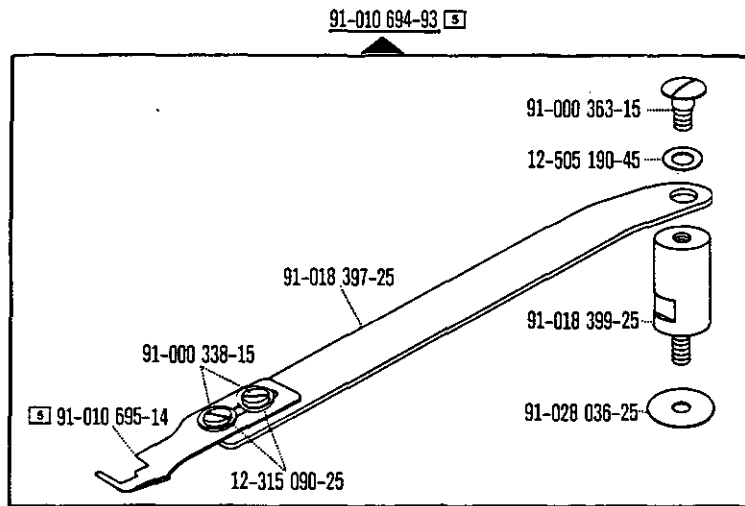
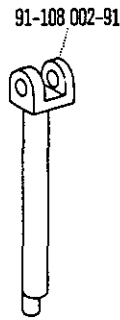
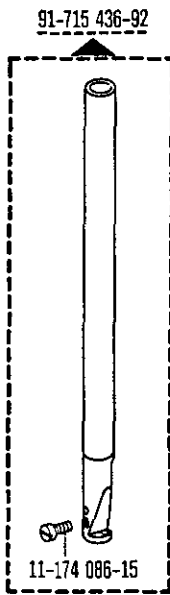
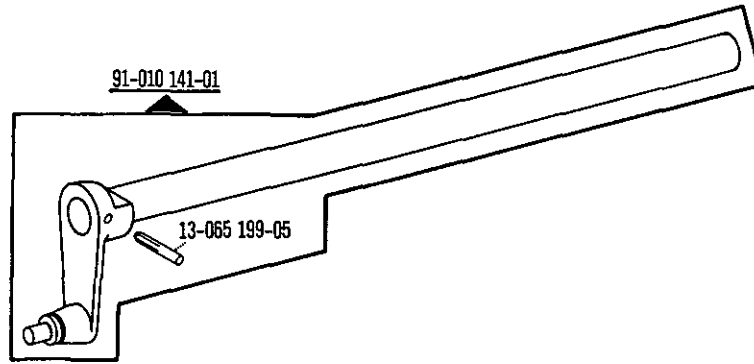

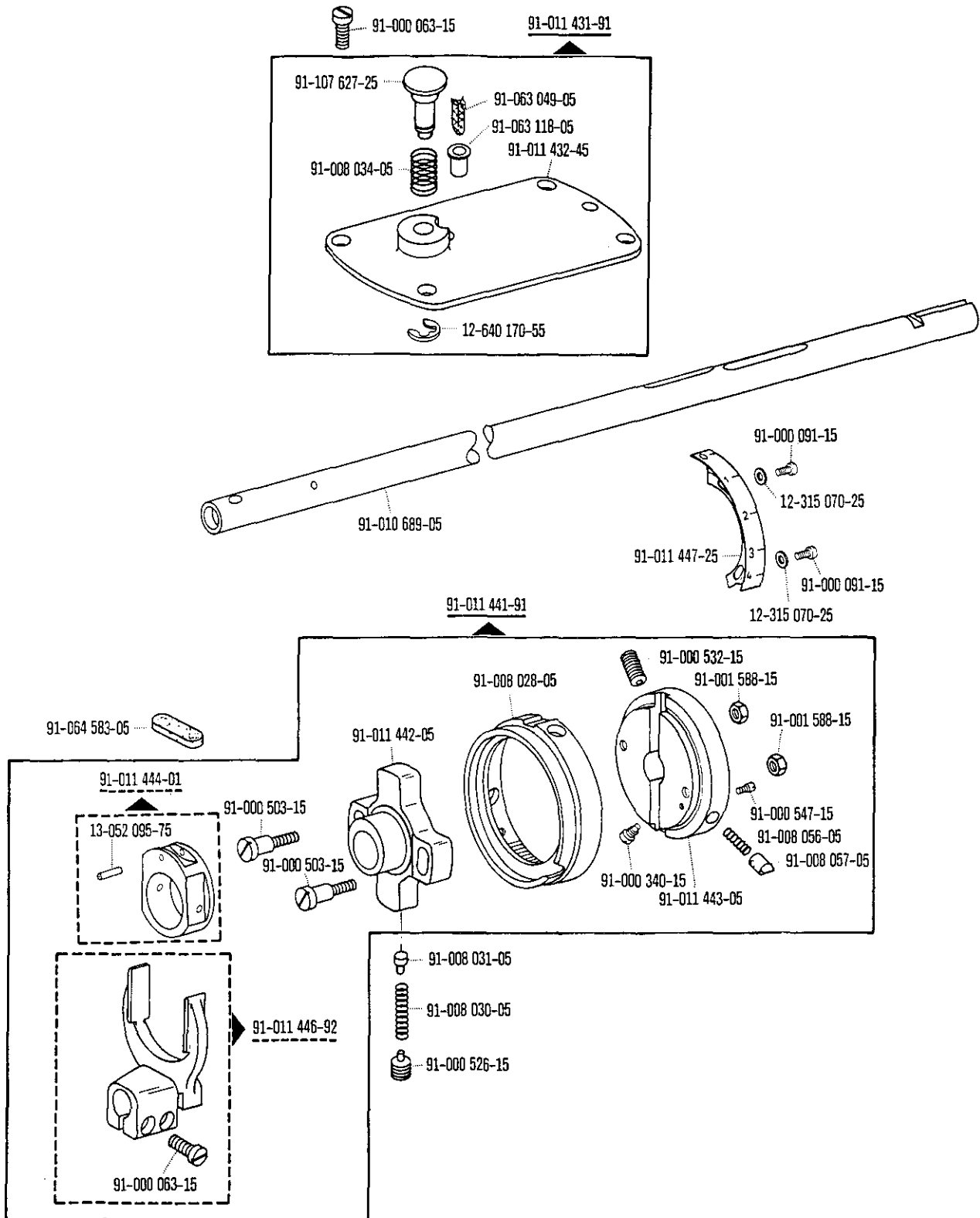

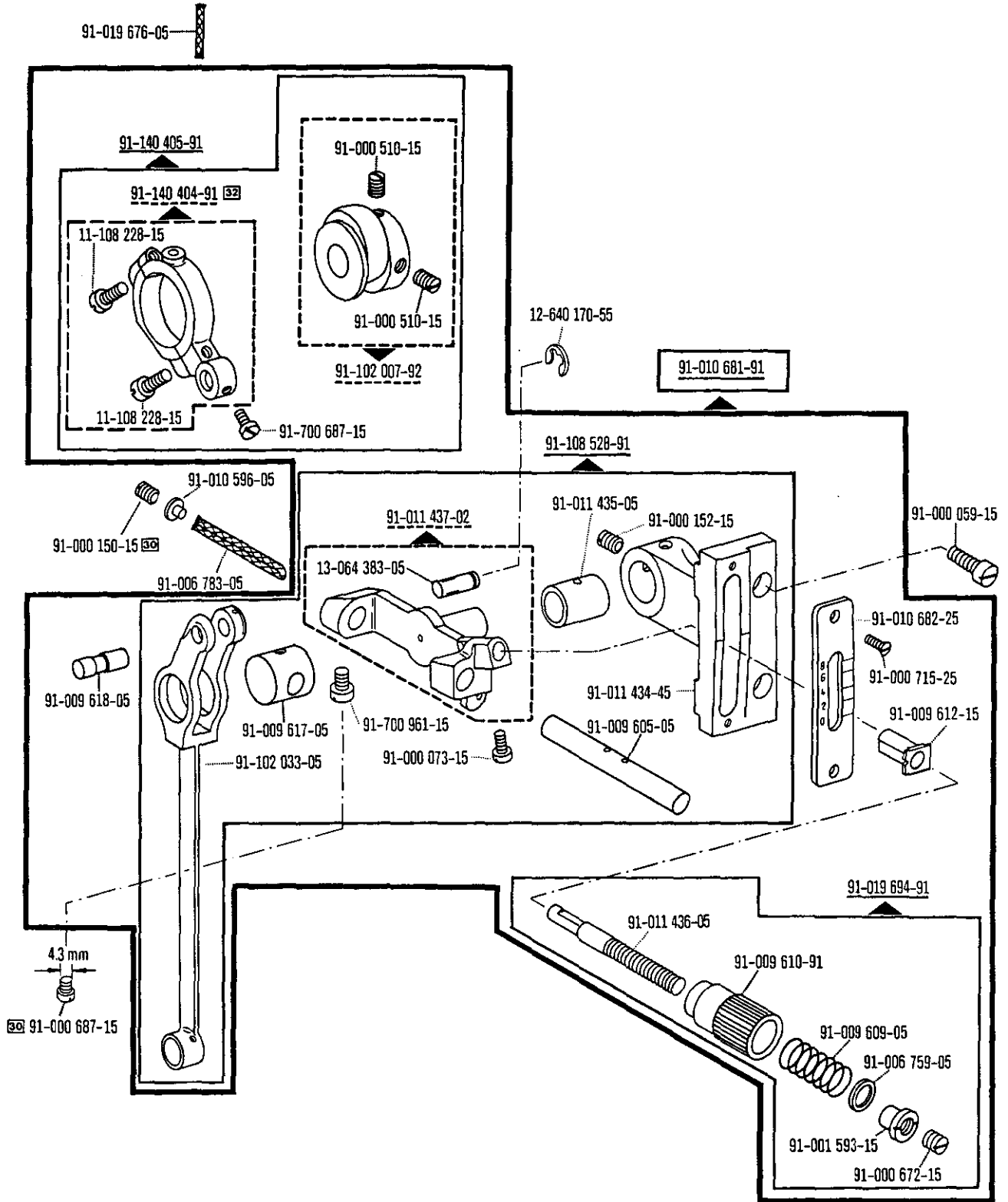

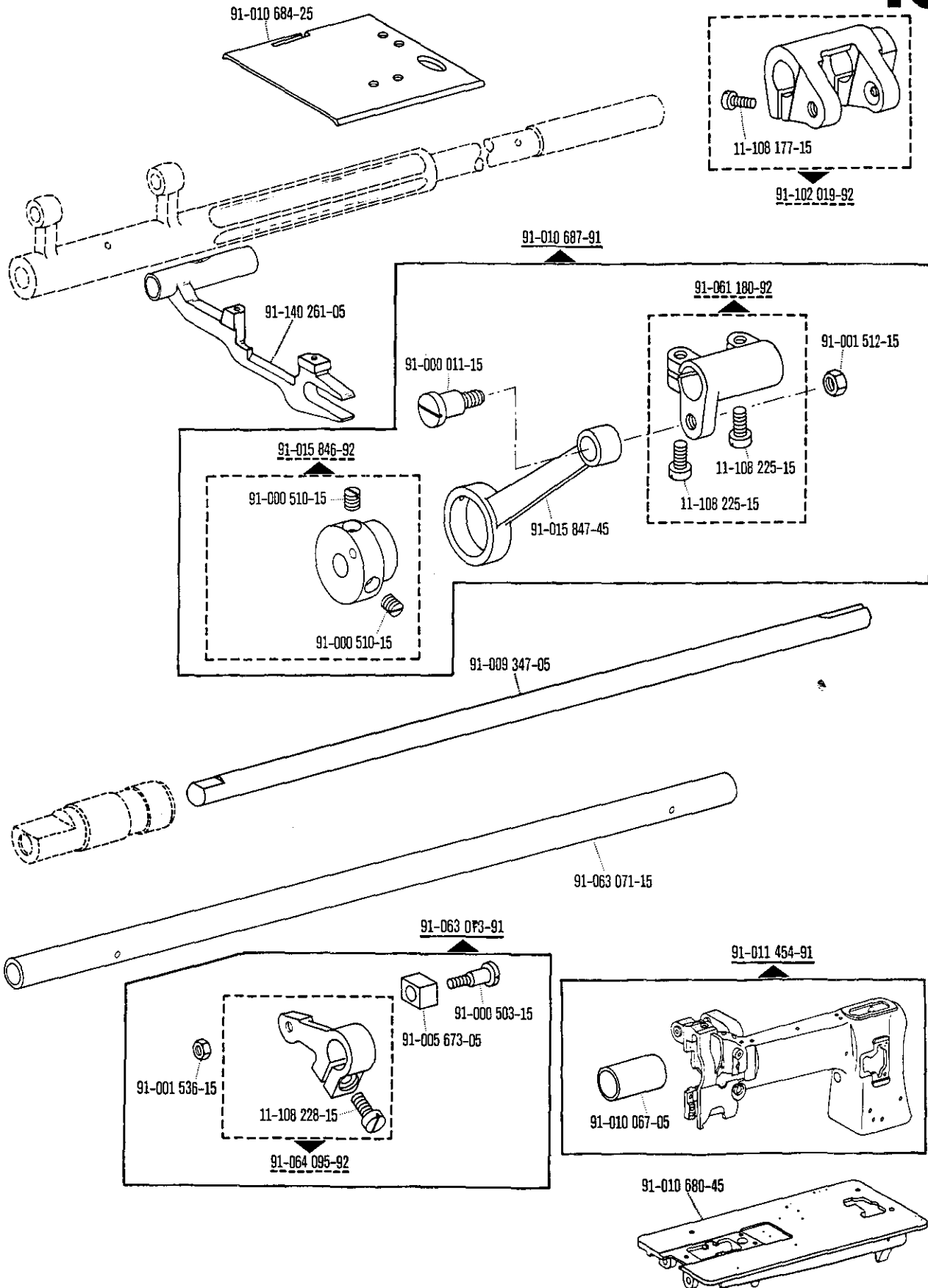

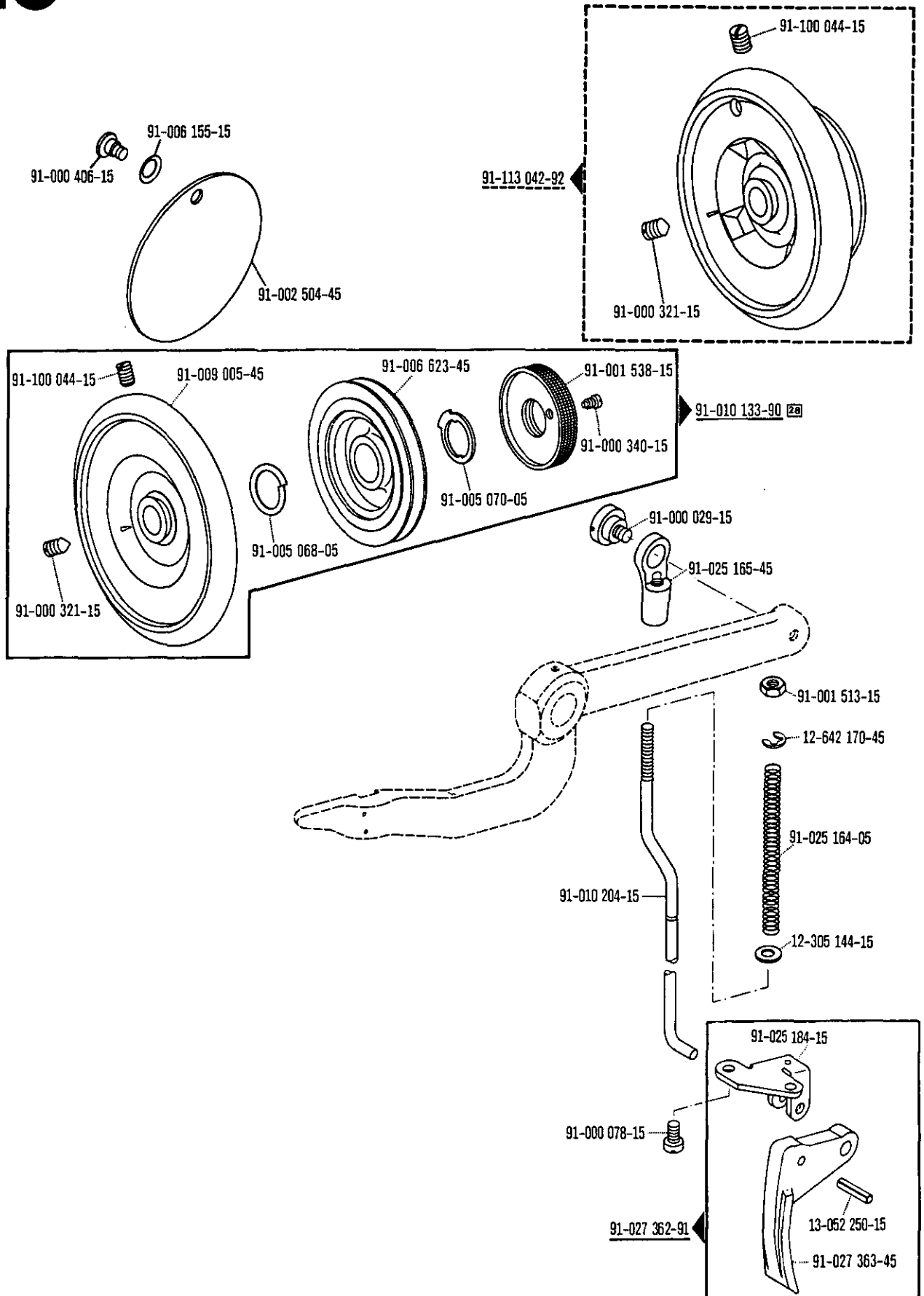

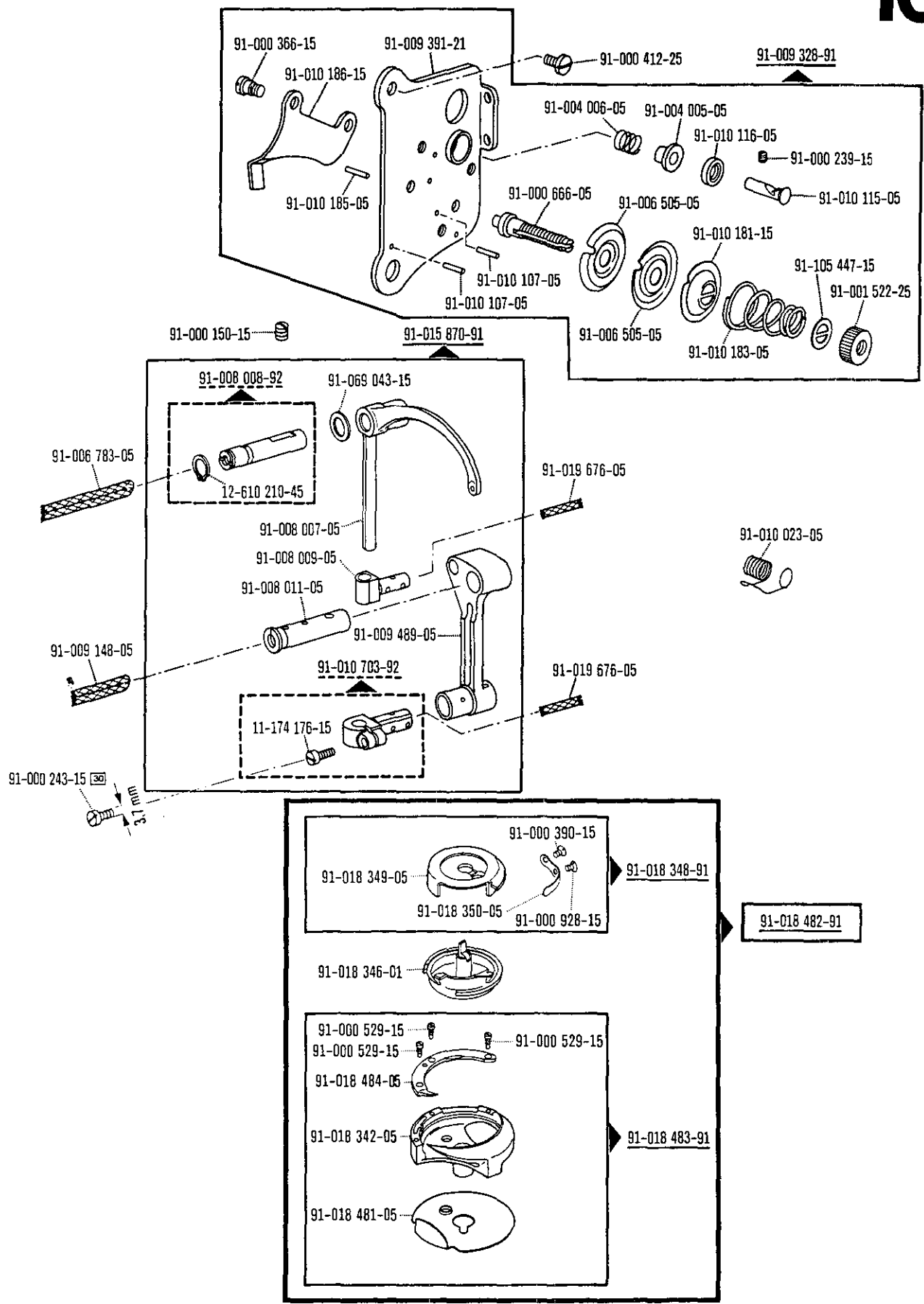

00-000 000-00 00-000 000-00 00-000 000-00 00-000 000-00 30 siehe Erläuterungen Seite 5
 see explanations on page 7
 voir legende page 9
 ver explicaciones de la página 11

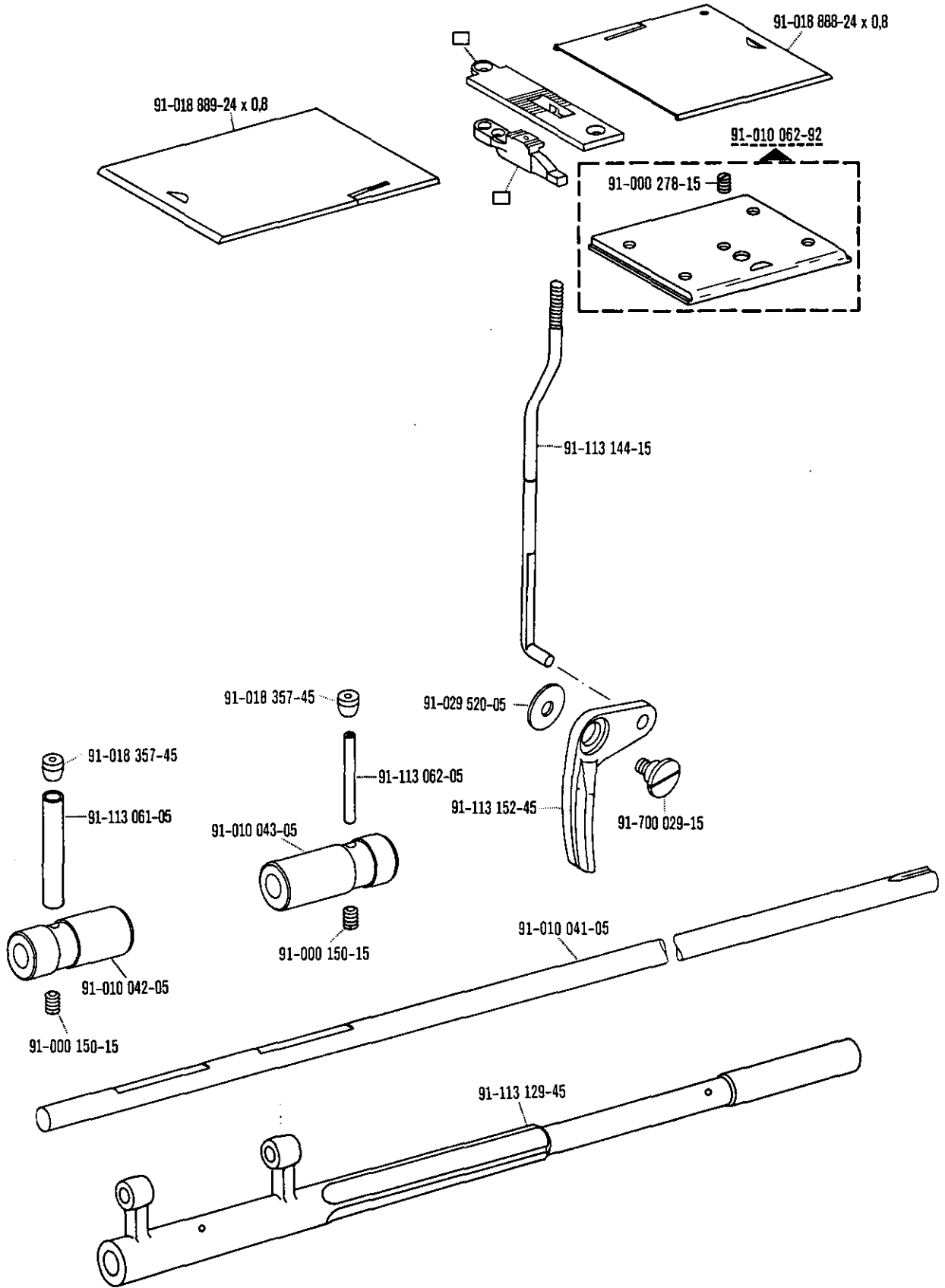

91-113 414-91 S

91-113 105-91

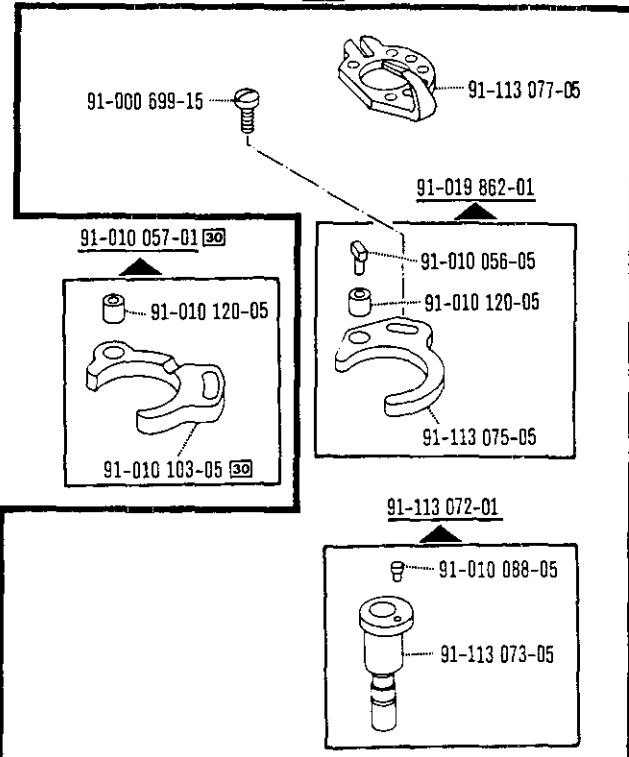
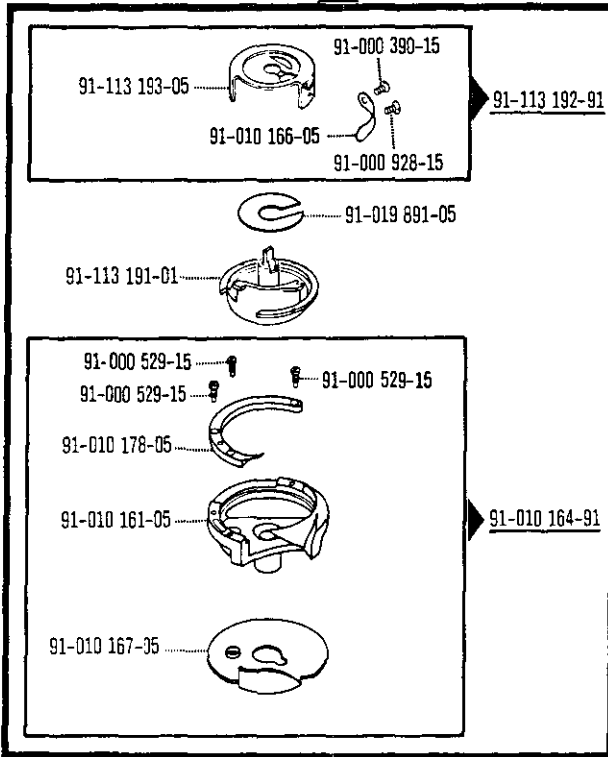

91-113 190-91 L

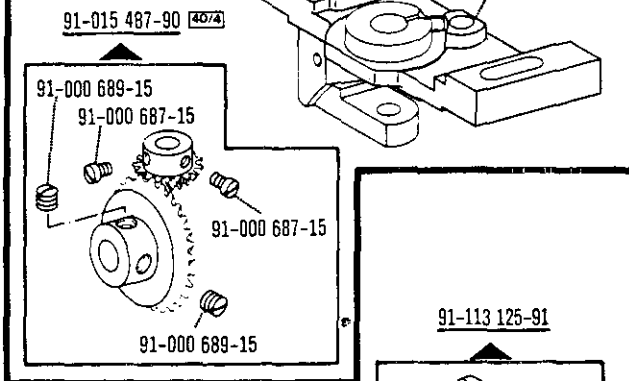
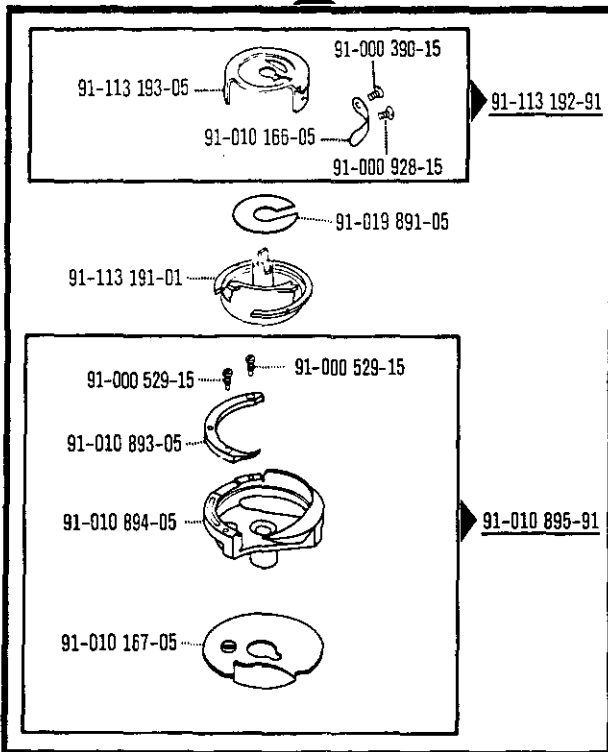

91-113 125-91

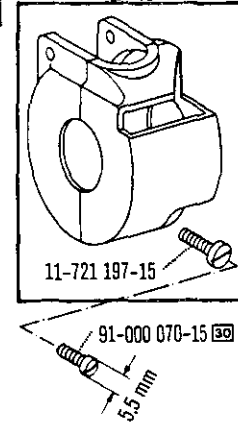

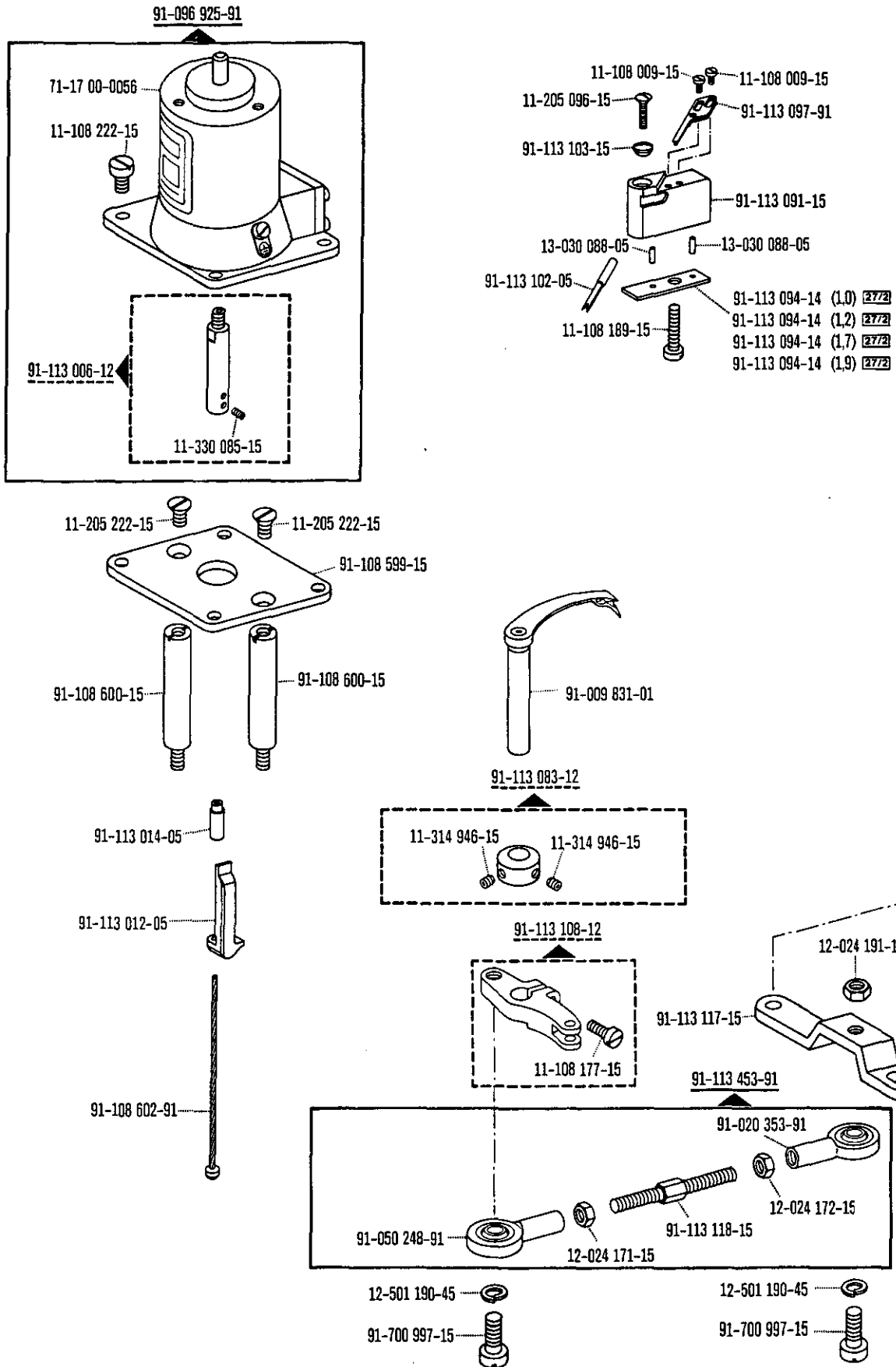

91-113 454-91

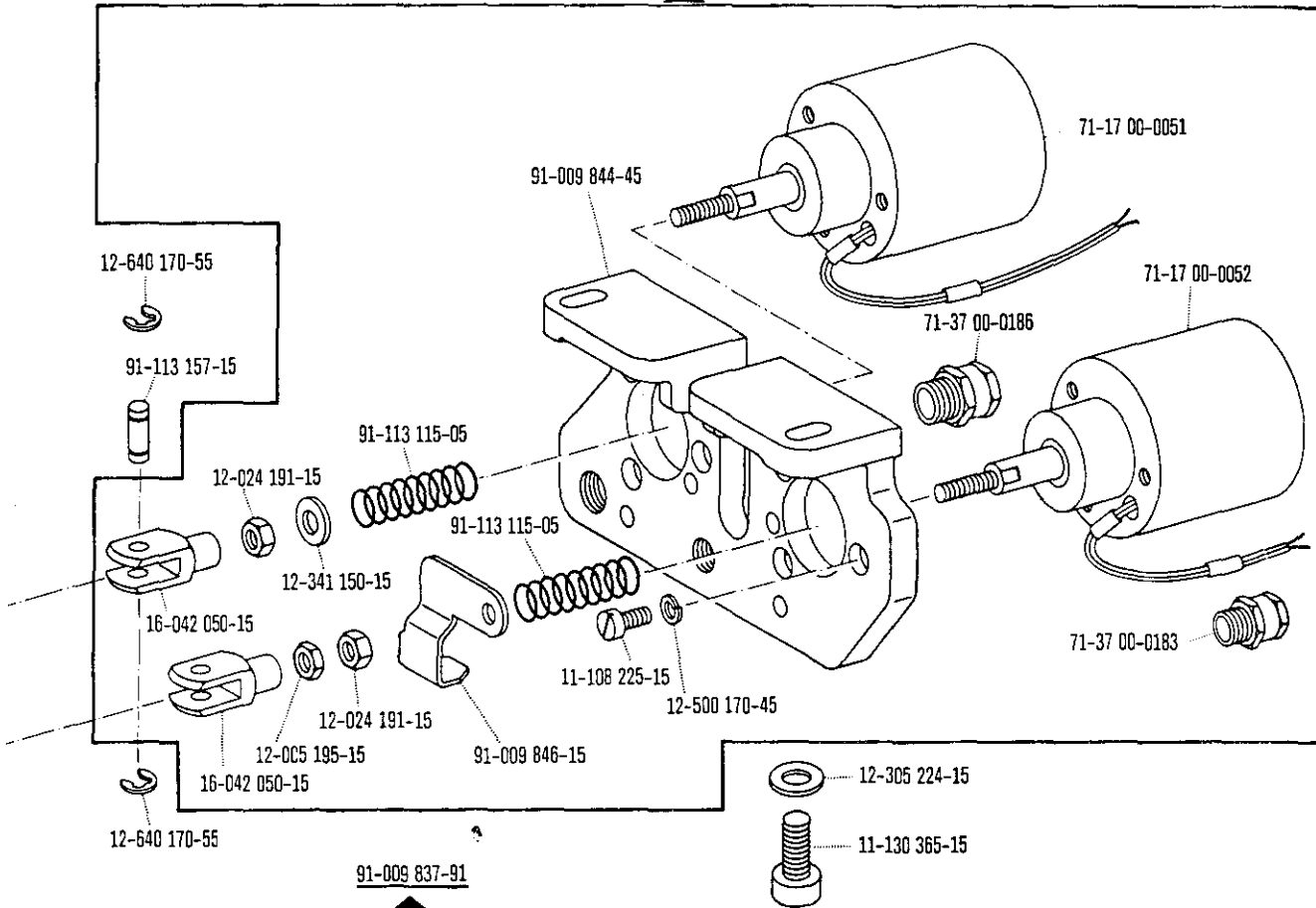

91-009 837-91

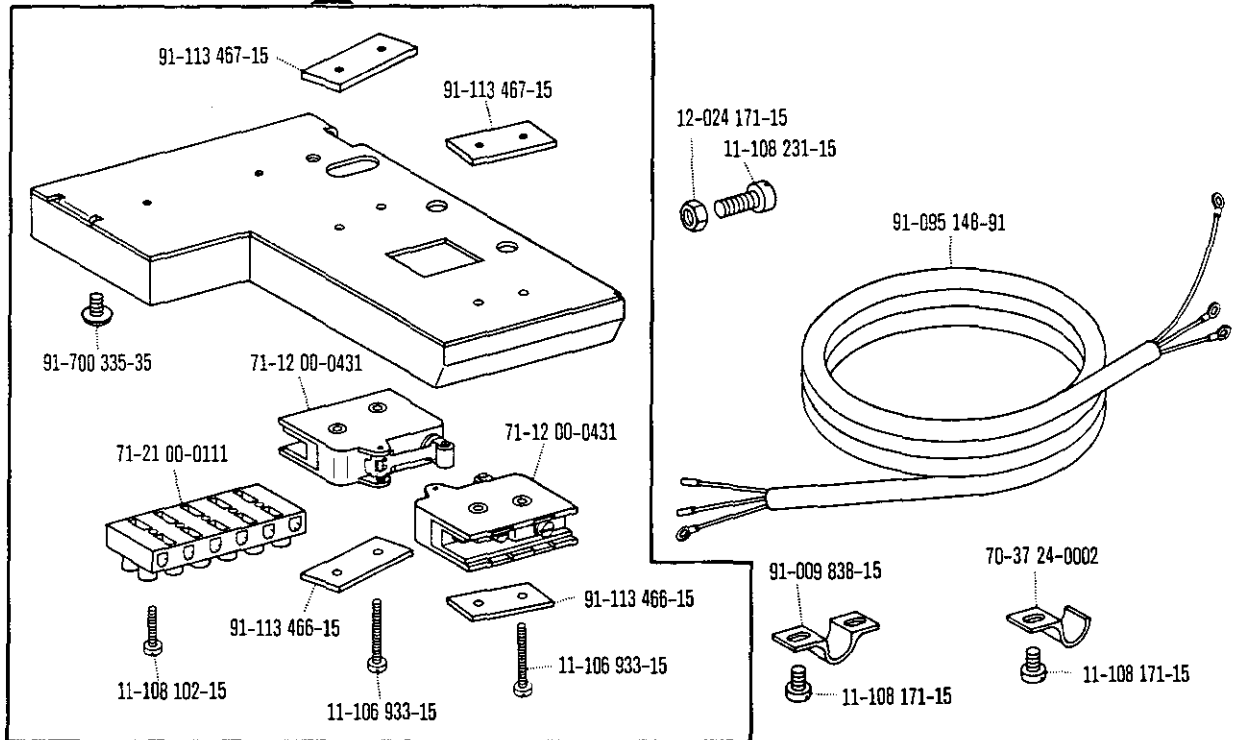

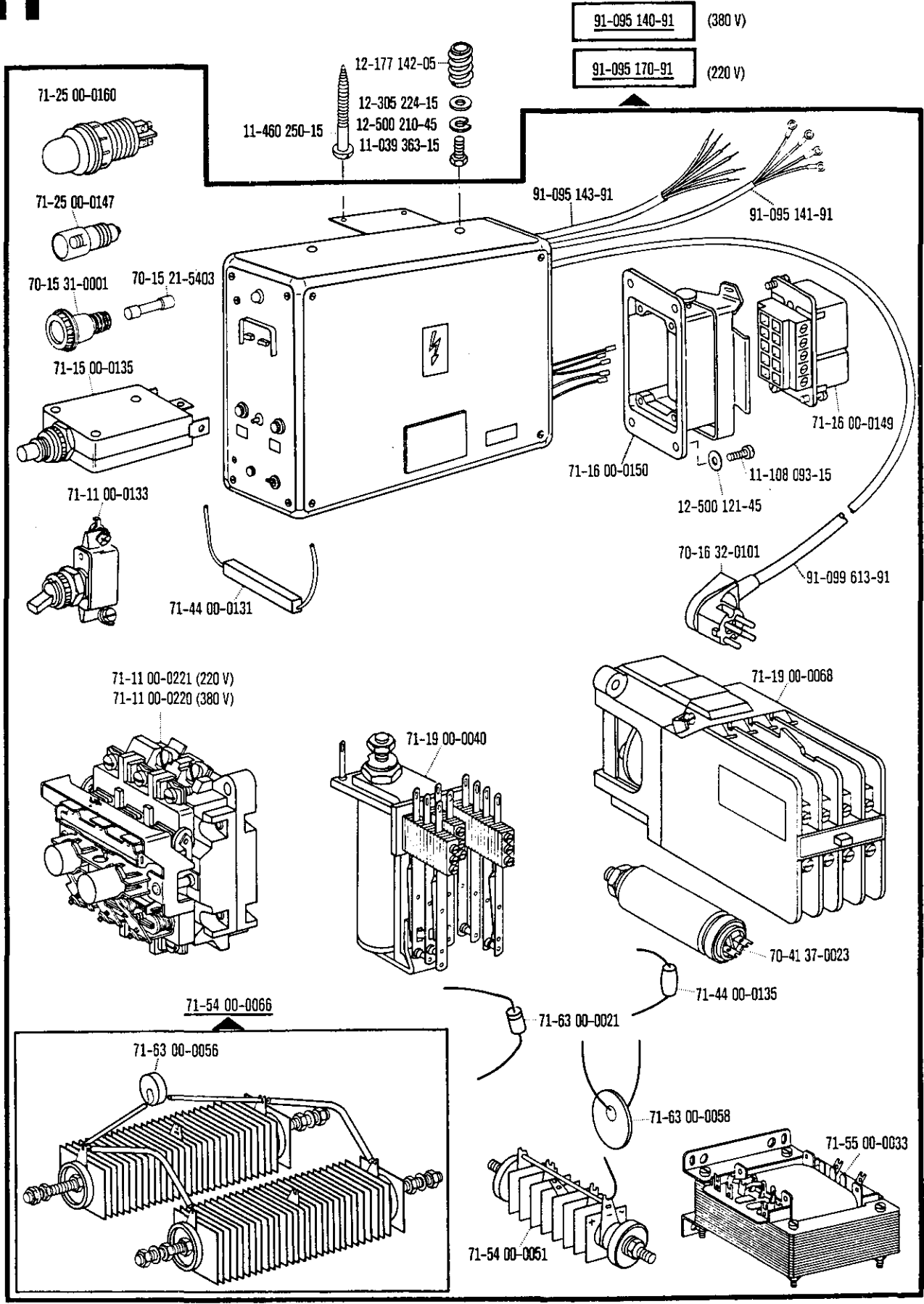

91-095 368-91

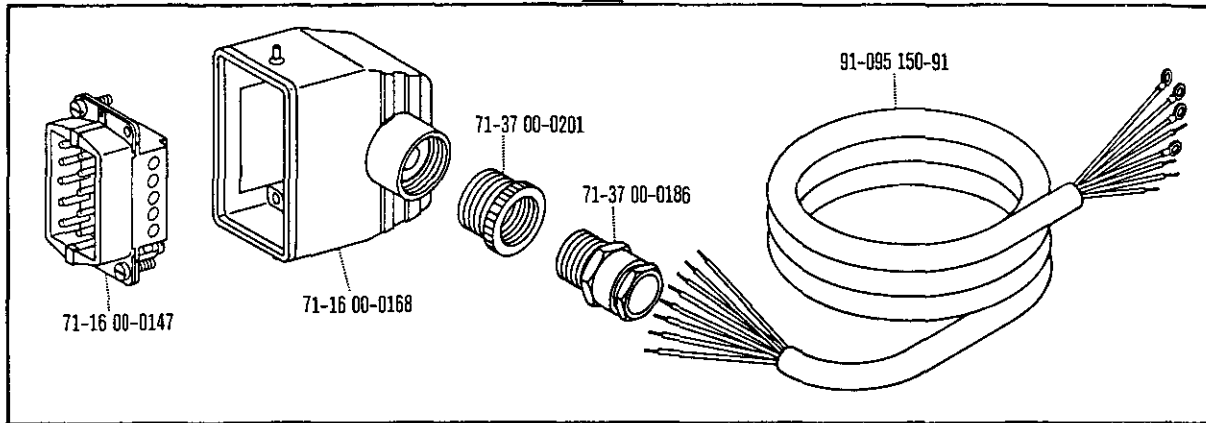

71-14 00-0003

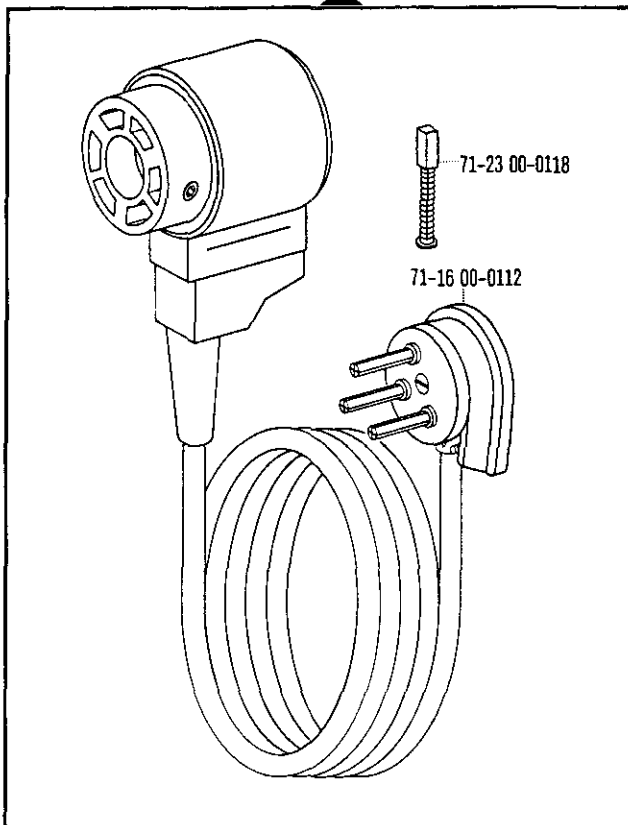

91-113 046-91

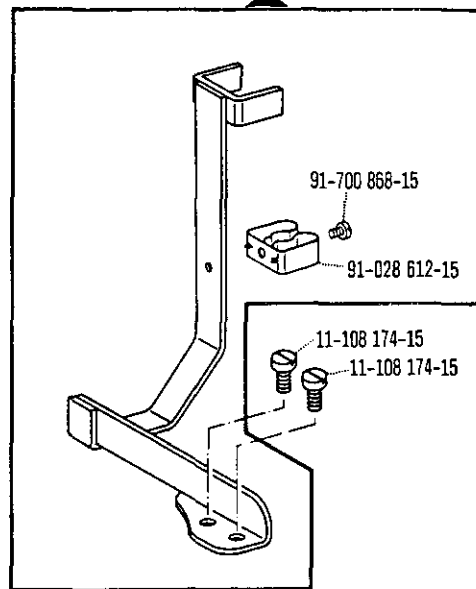

91-107 694-91

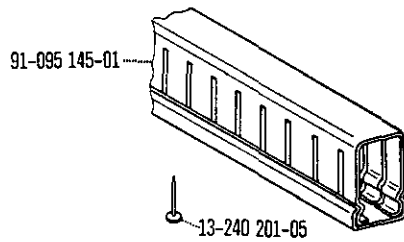
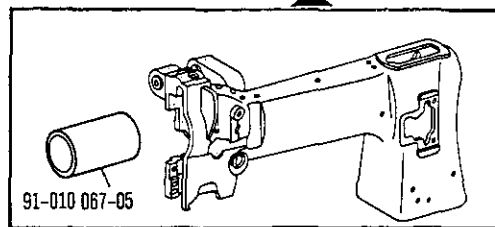

91-113 063-05 

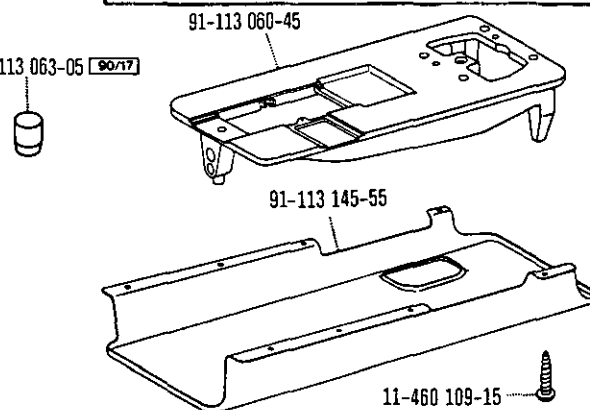

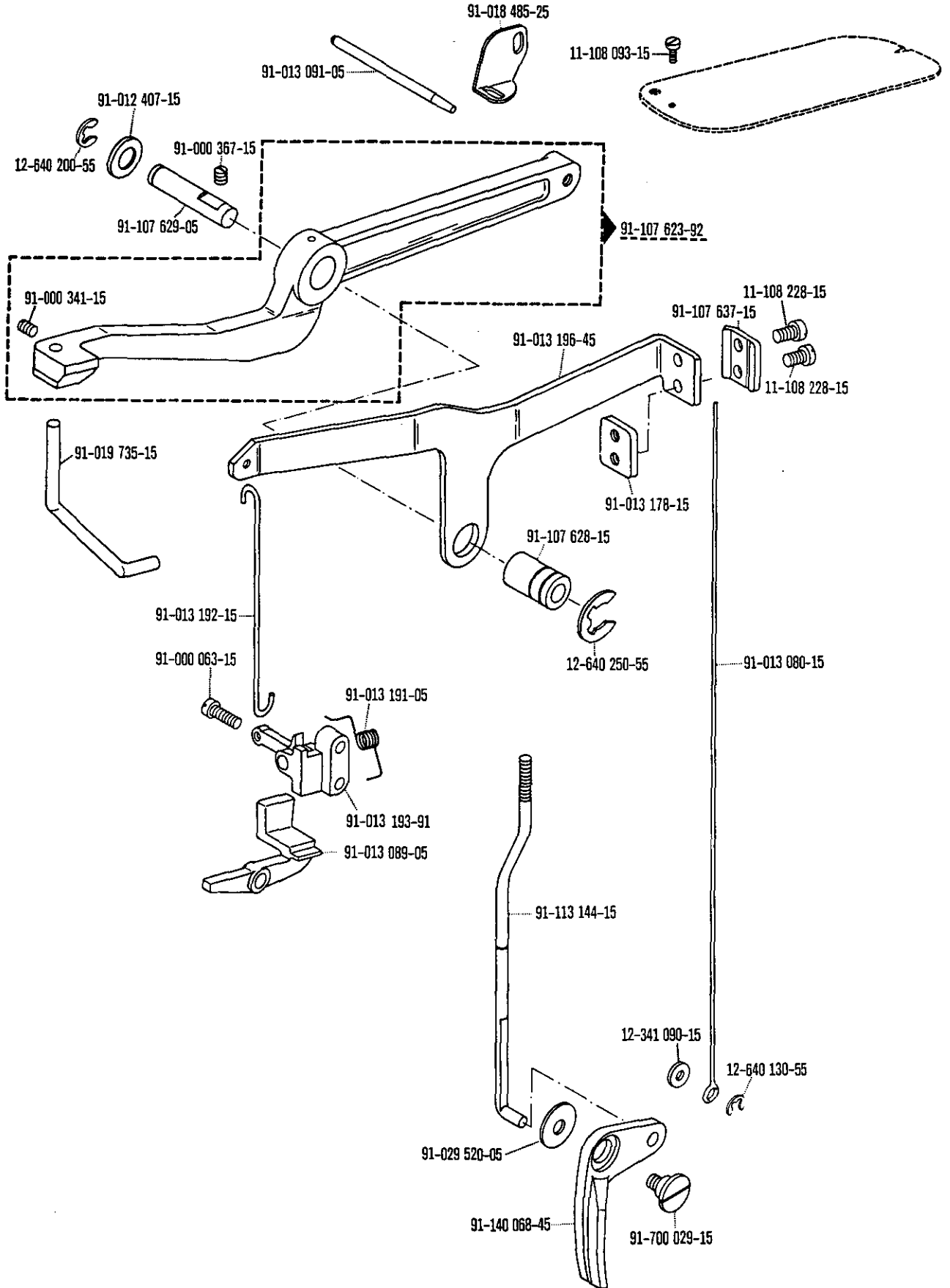

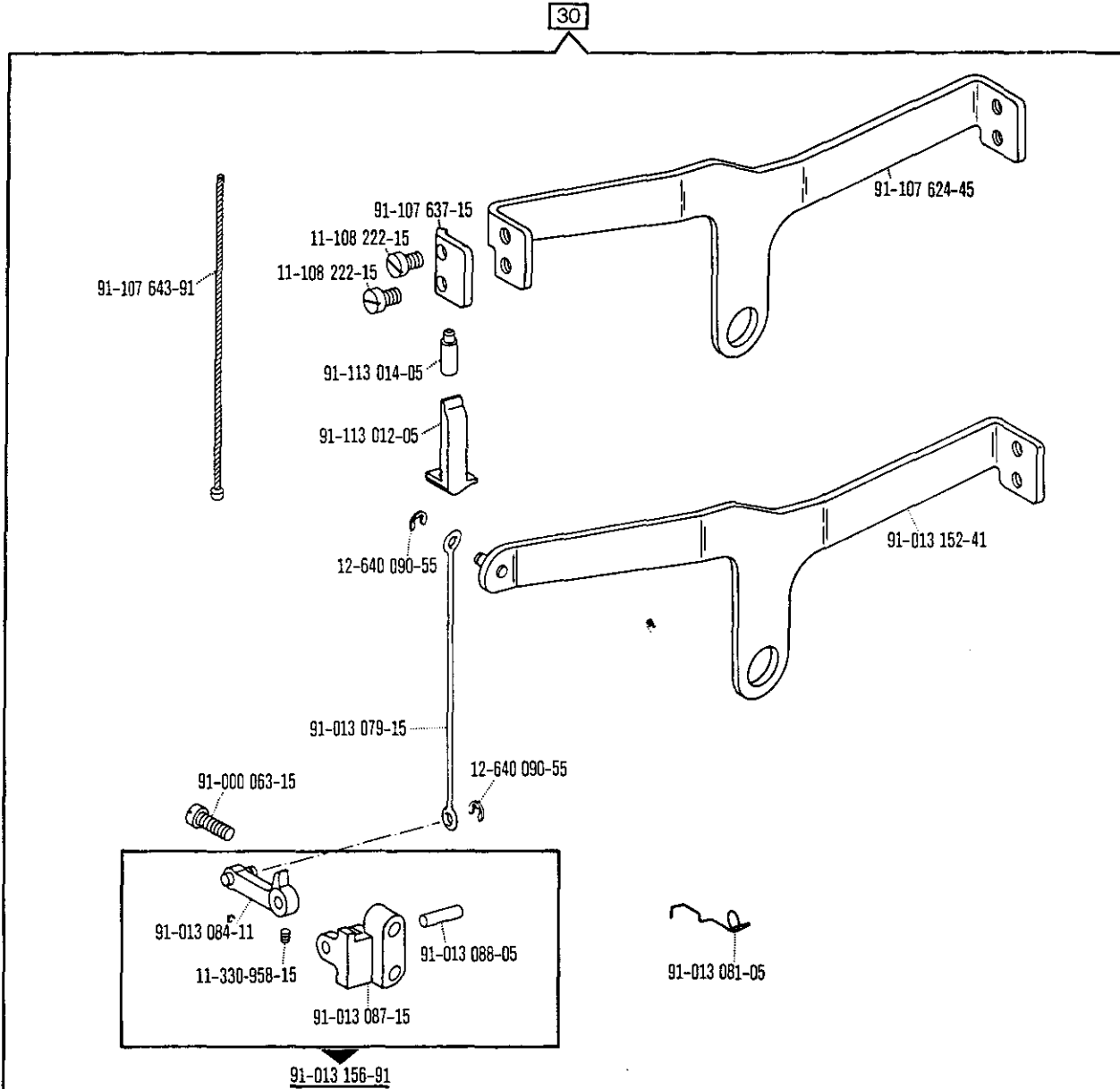

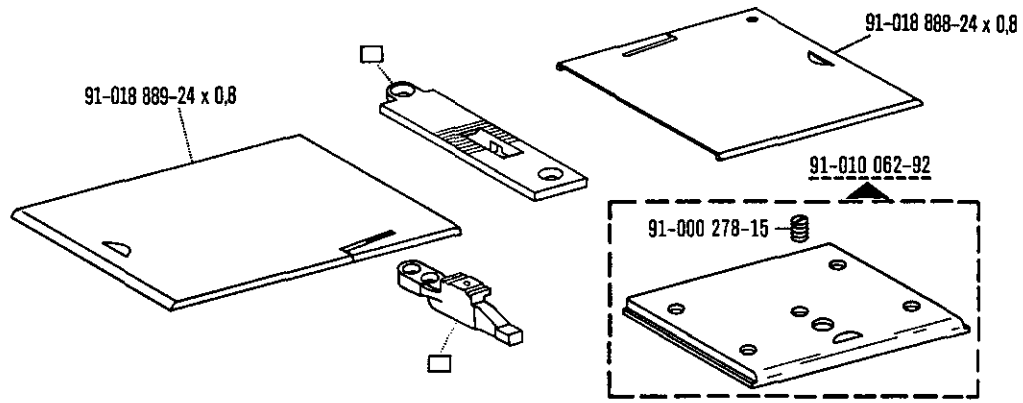

Pfaff 145

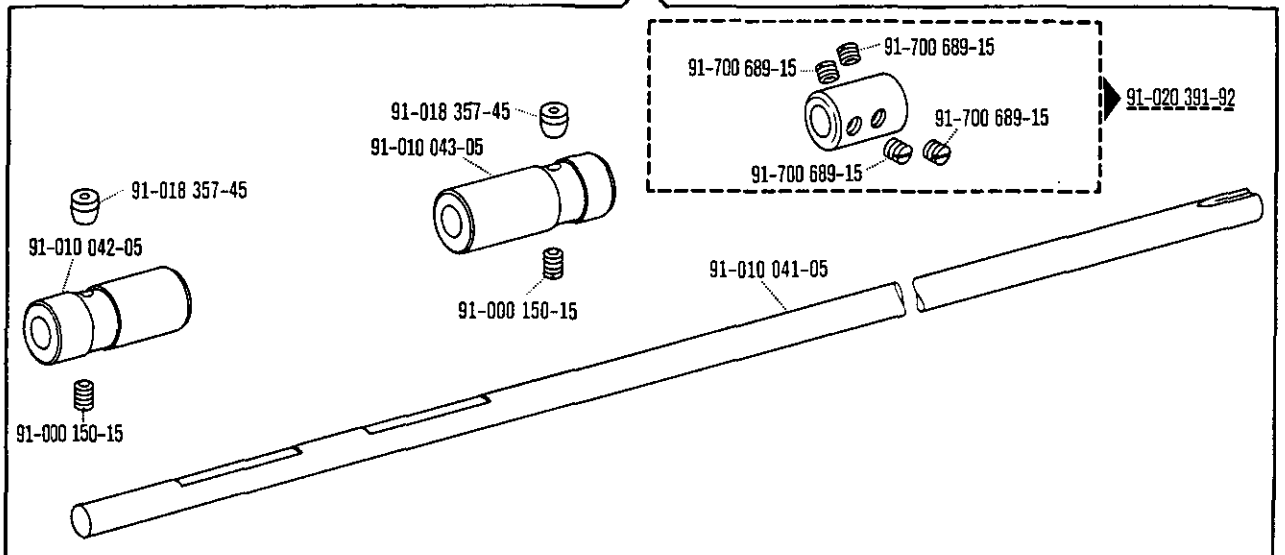

Pfaff 545

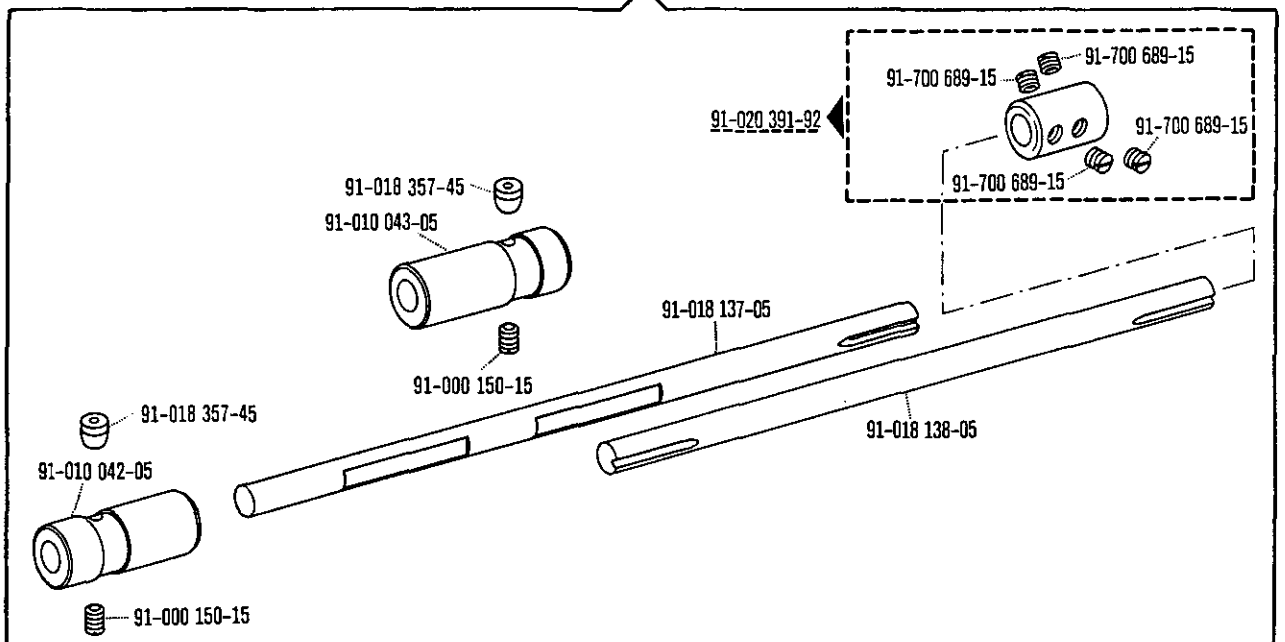

91-113 414-91  (Pfaff 145)

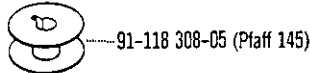
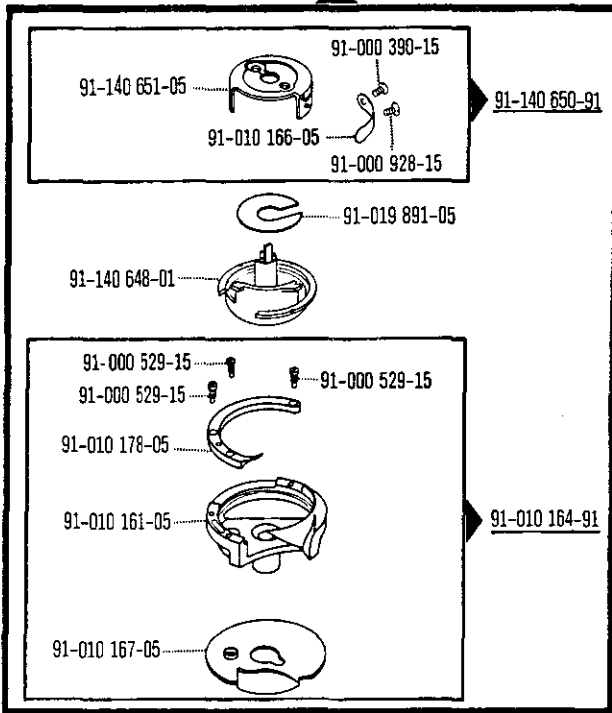

91-018 680-91  (Pfaff 545)

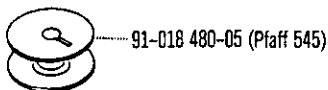
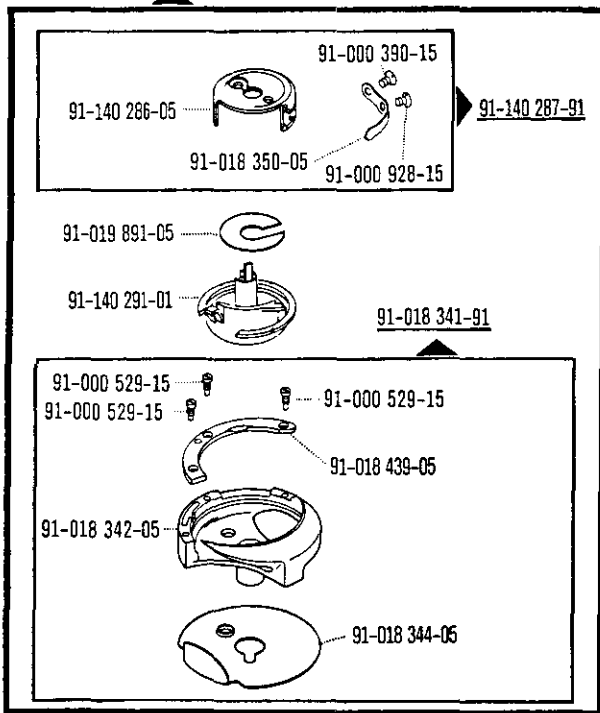

91-018 793-91 (-900/11; -900/51)

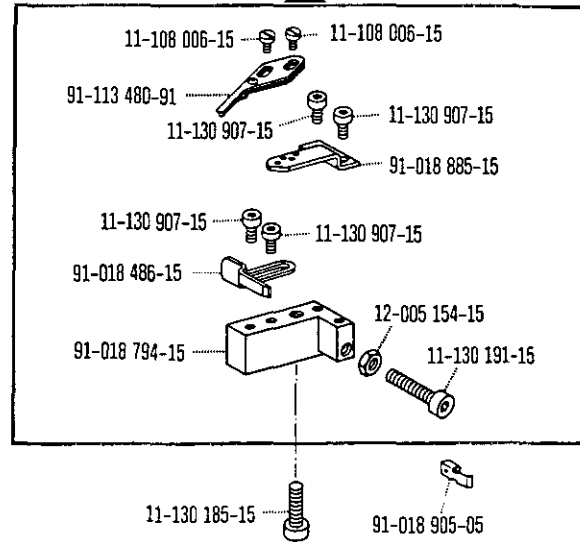

91-013 157-91 (Pfaff 145-900/16; -900/56)

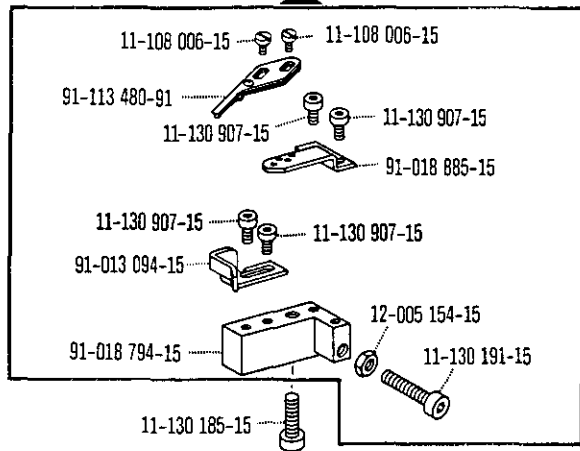

91-018 146-91 (Pfaff 545-900/16; -900/56)

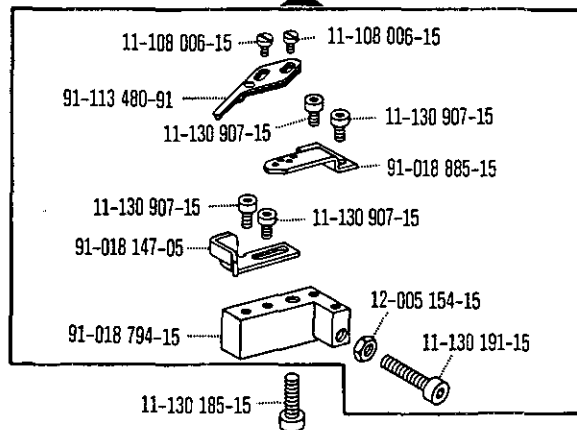

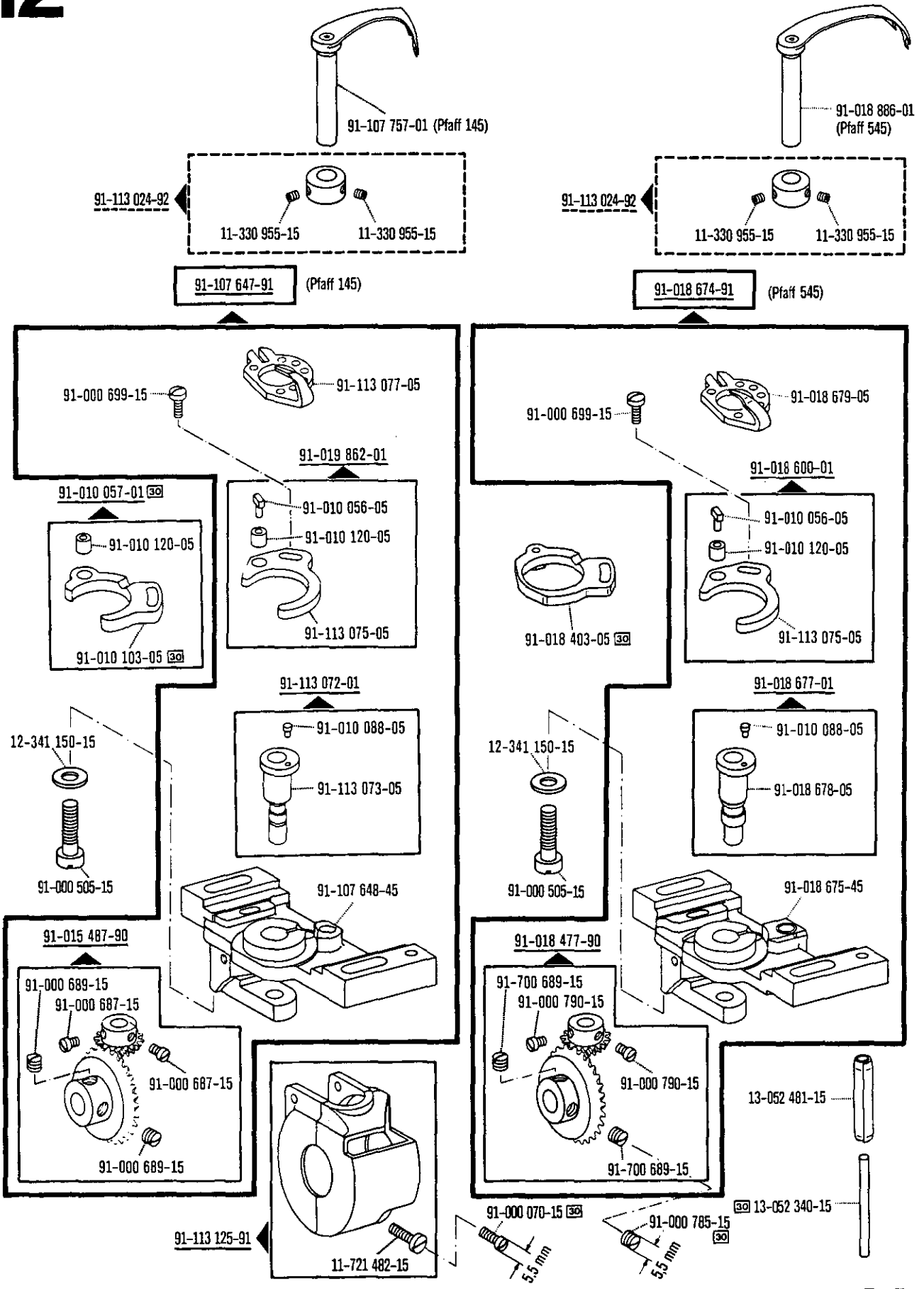

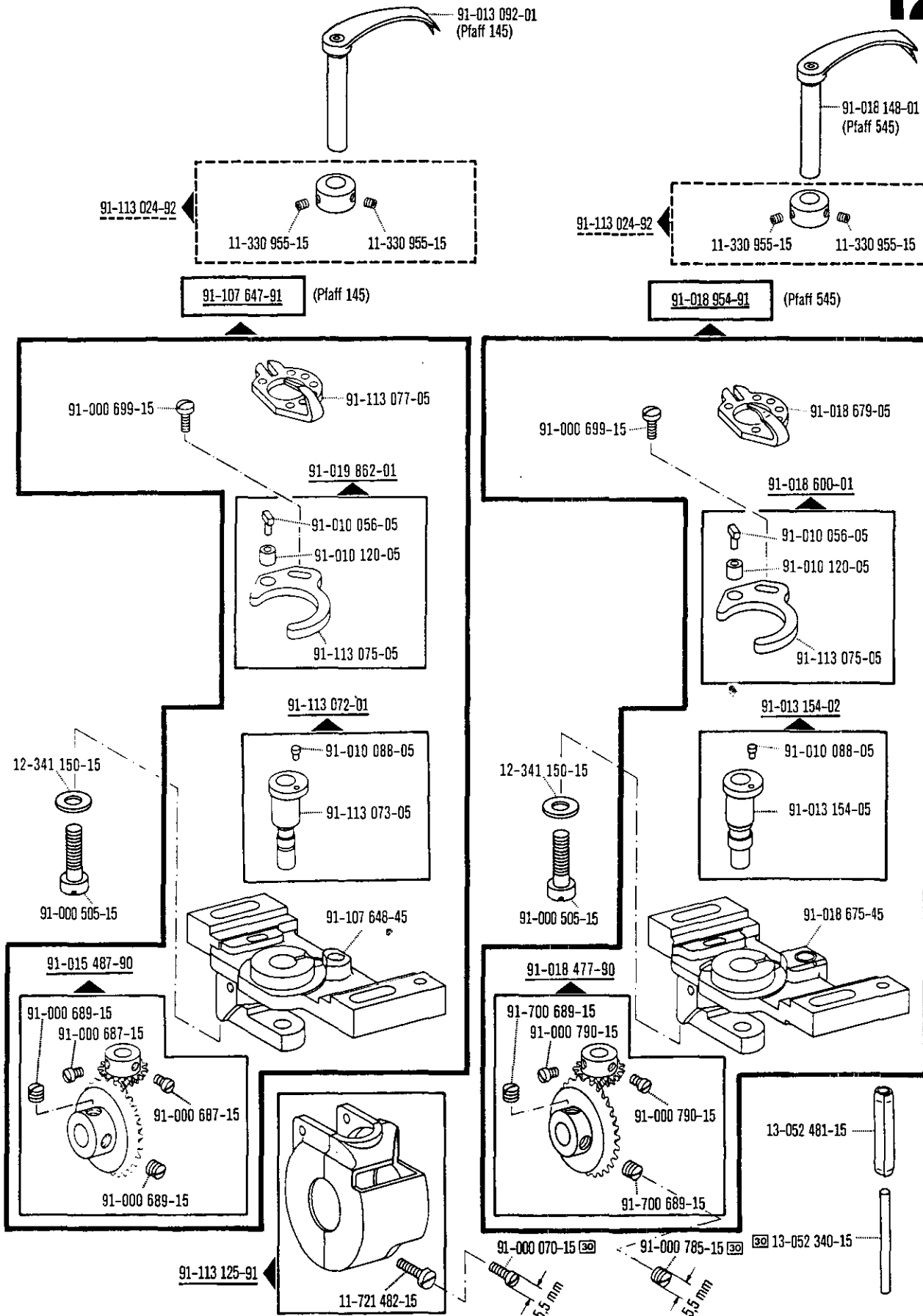

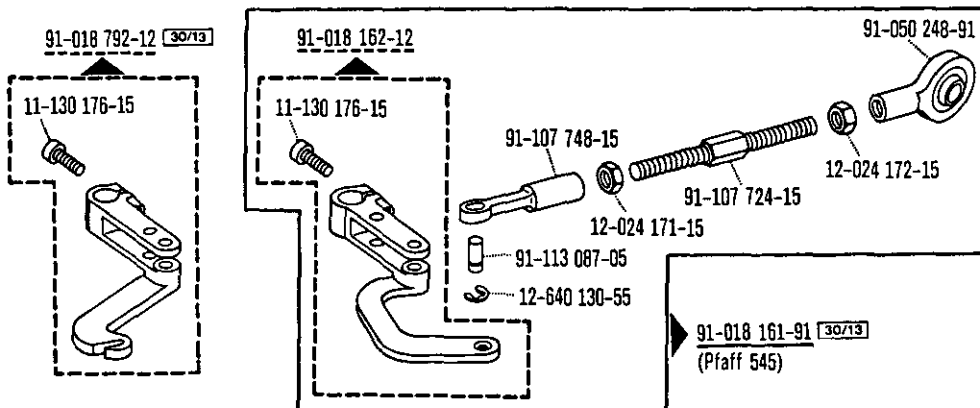
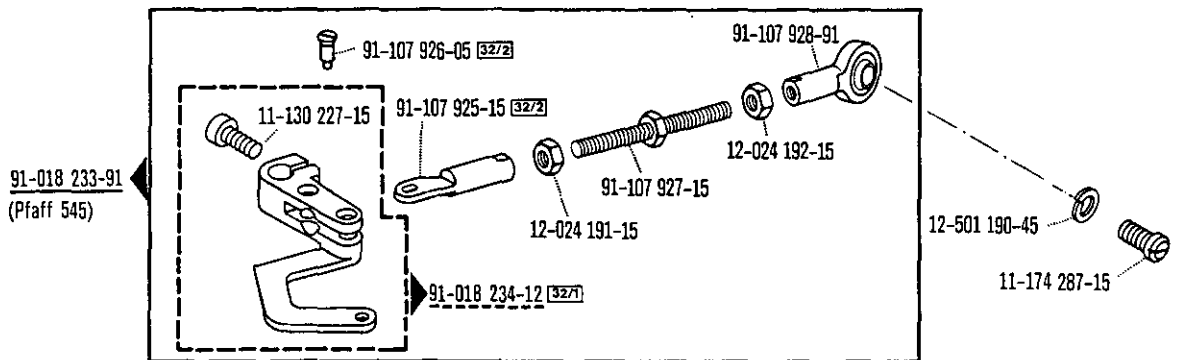
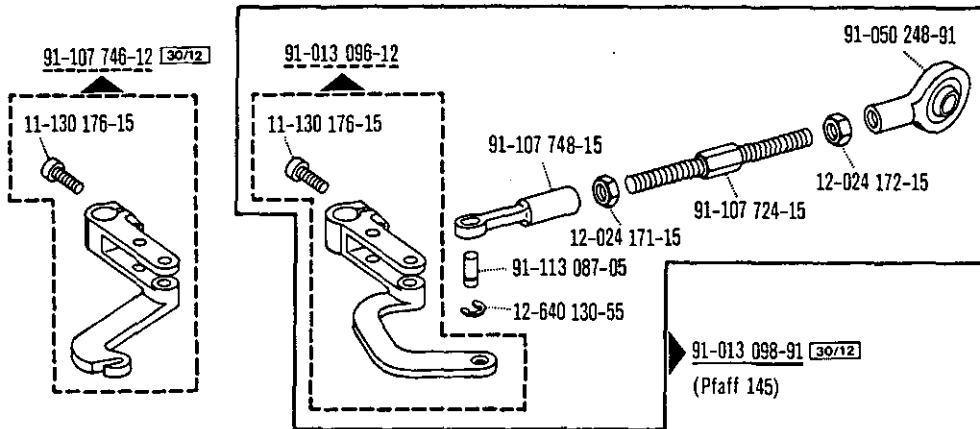
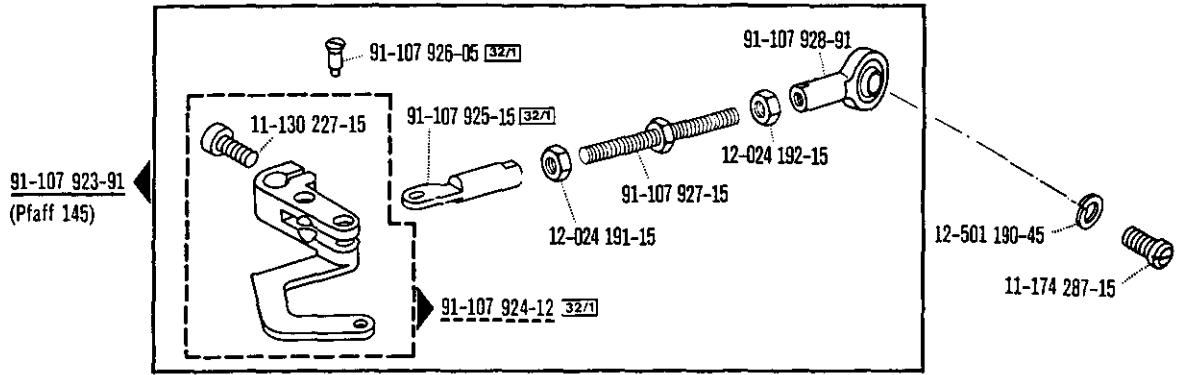

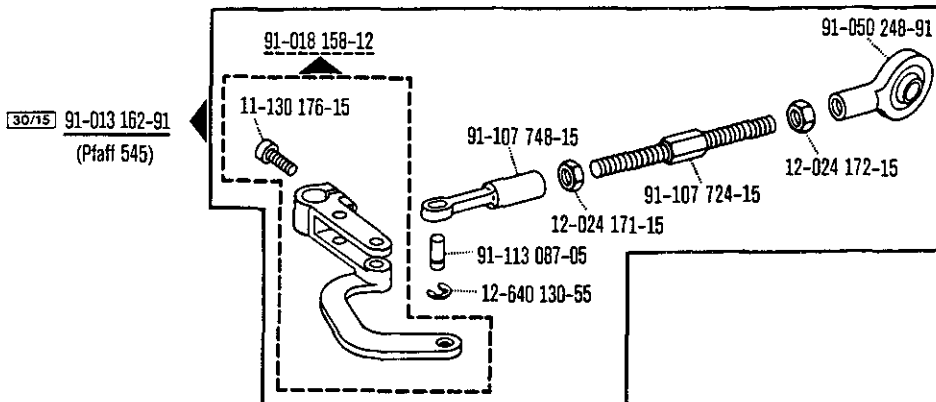
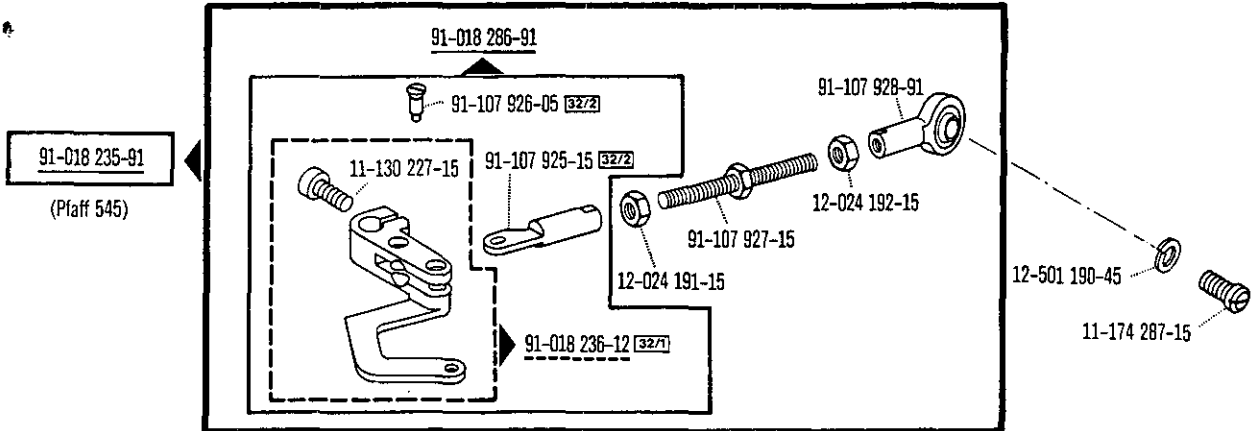
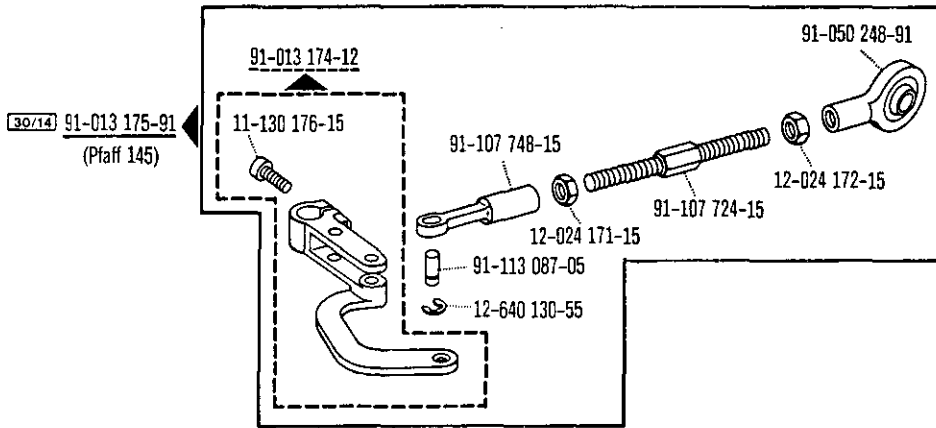
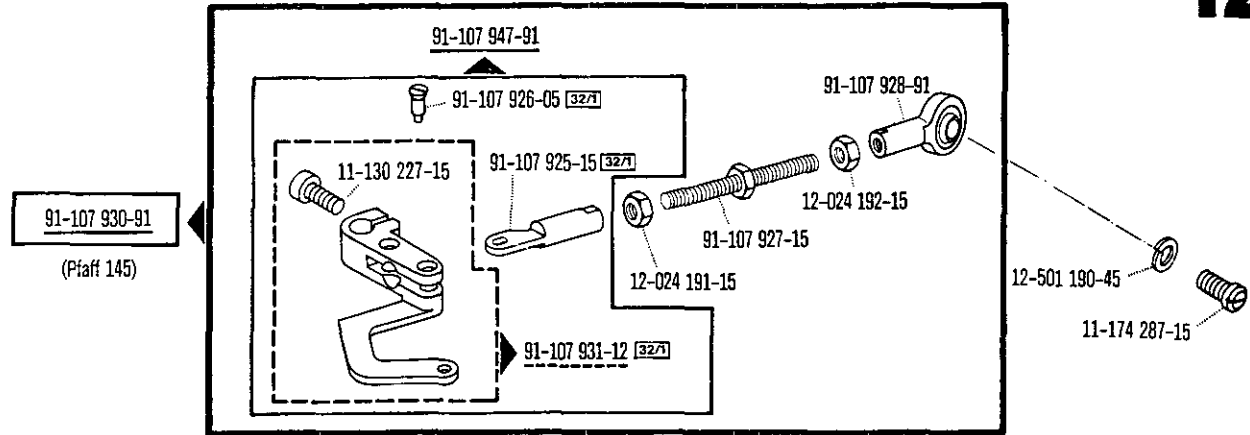

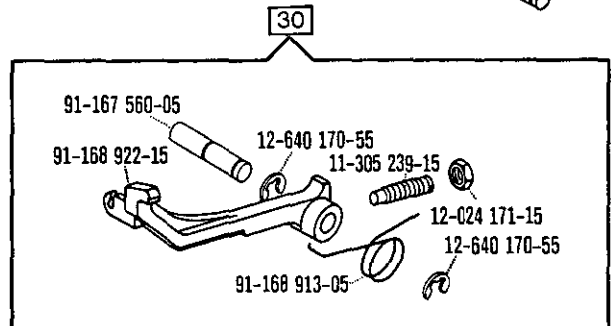
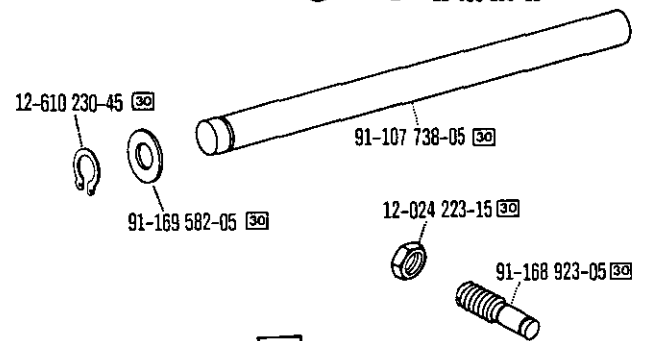
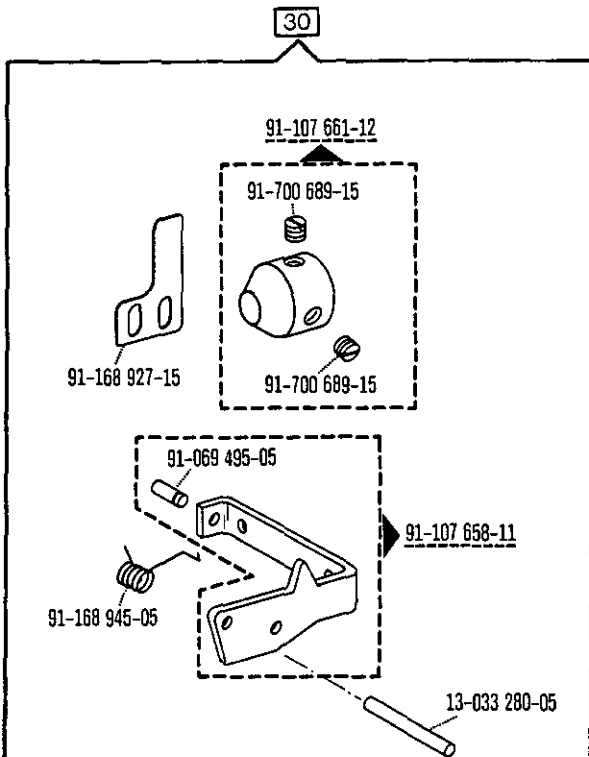
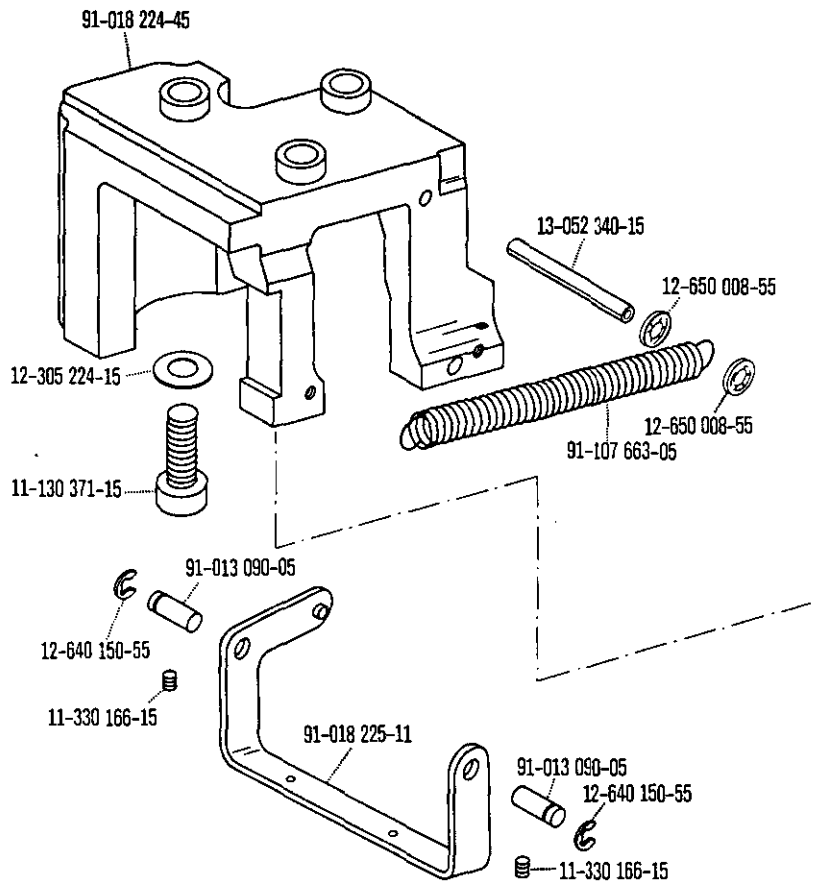
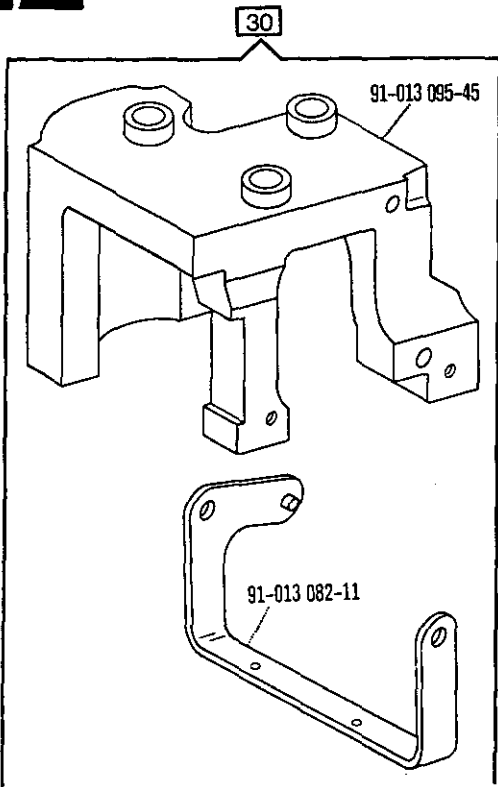

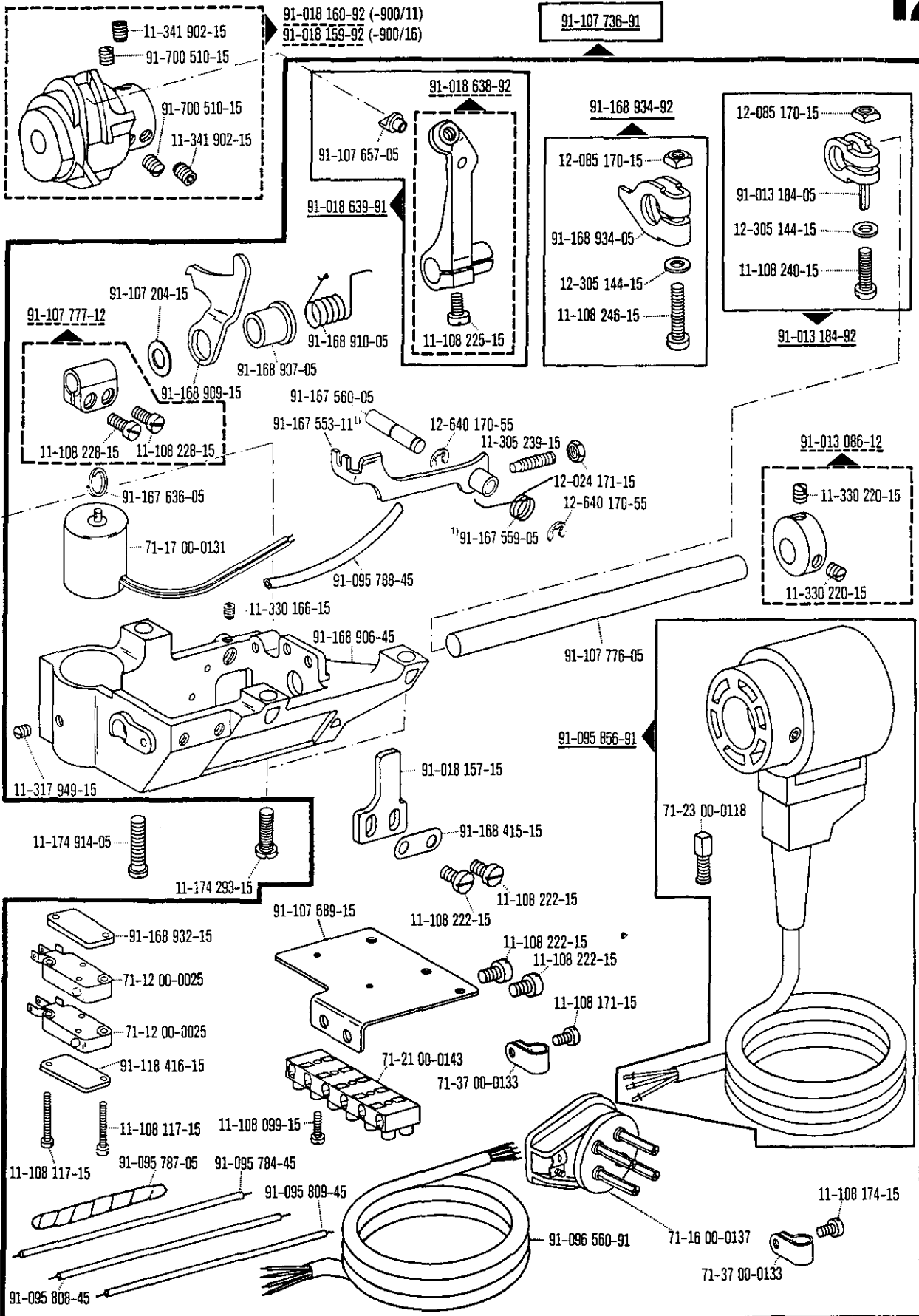

00-000 000-00 00-000 000-00 00-000 000-00 00-000 000-00 ^{307G} siehe Erläuterungen Seite 5
 see explanations on page 7
 voir légende page 9

¹⁾ Frühere Ausführung siehe Seite 56
 Earlier version, see page 56
 Ancienne version, voir page 56

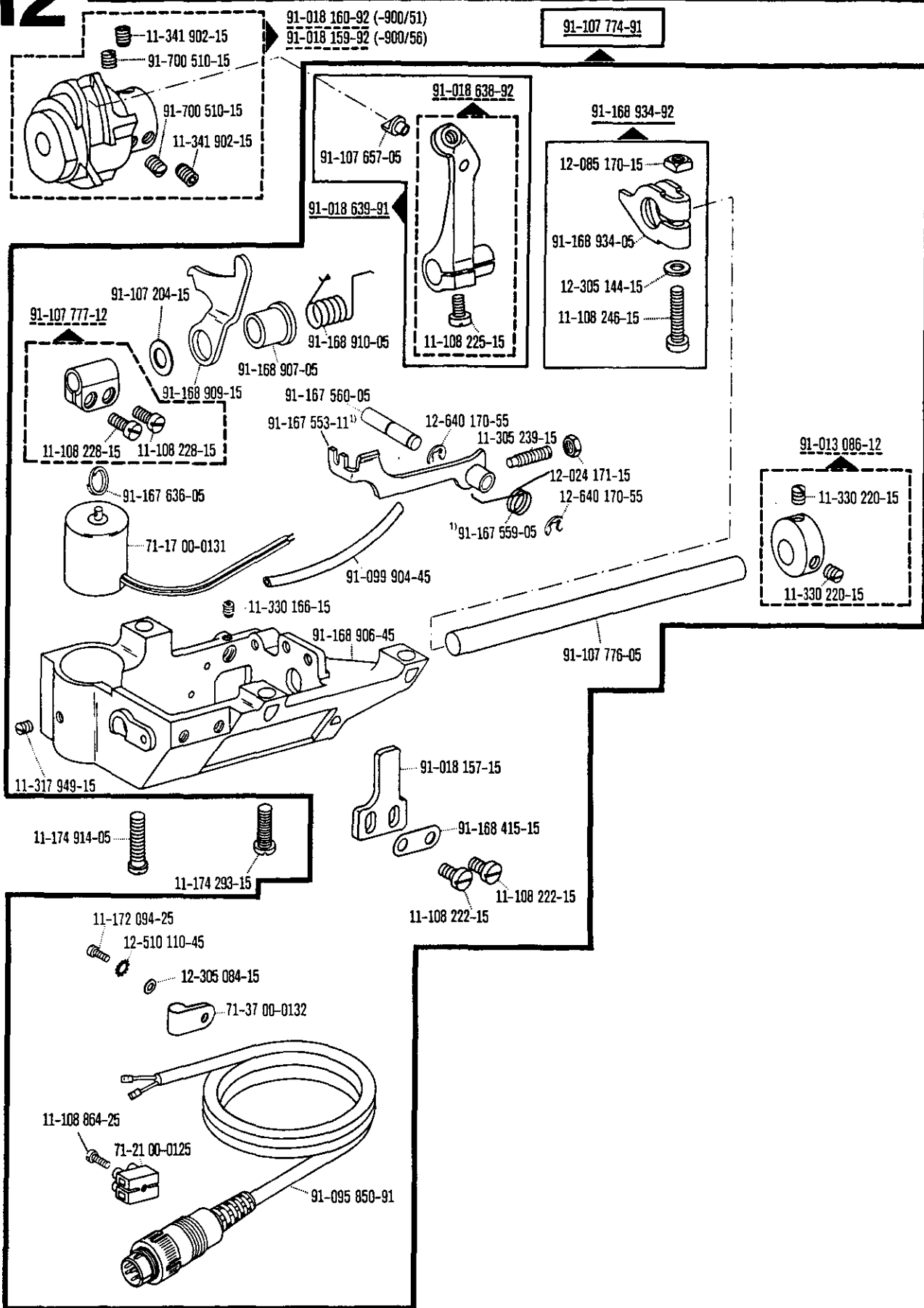

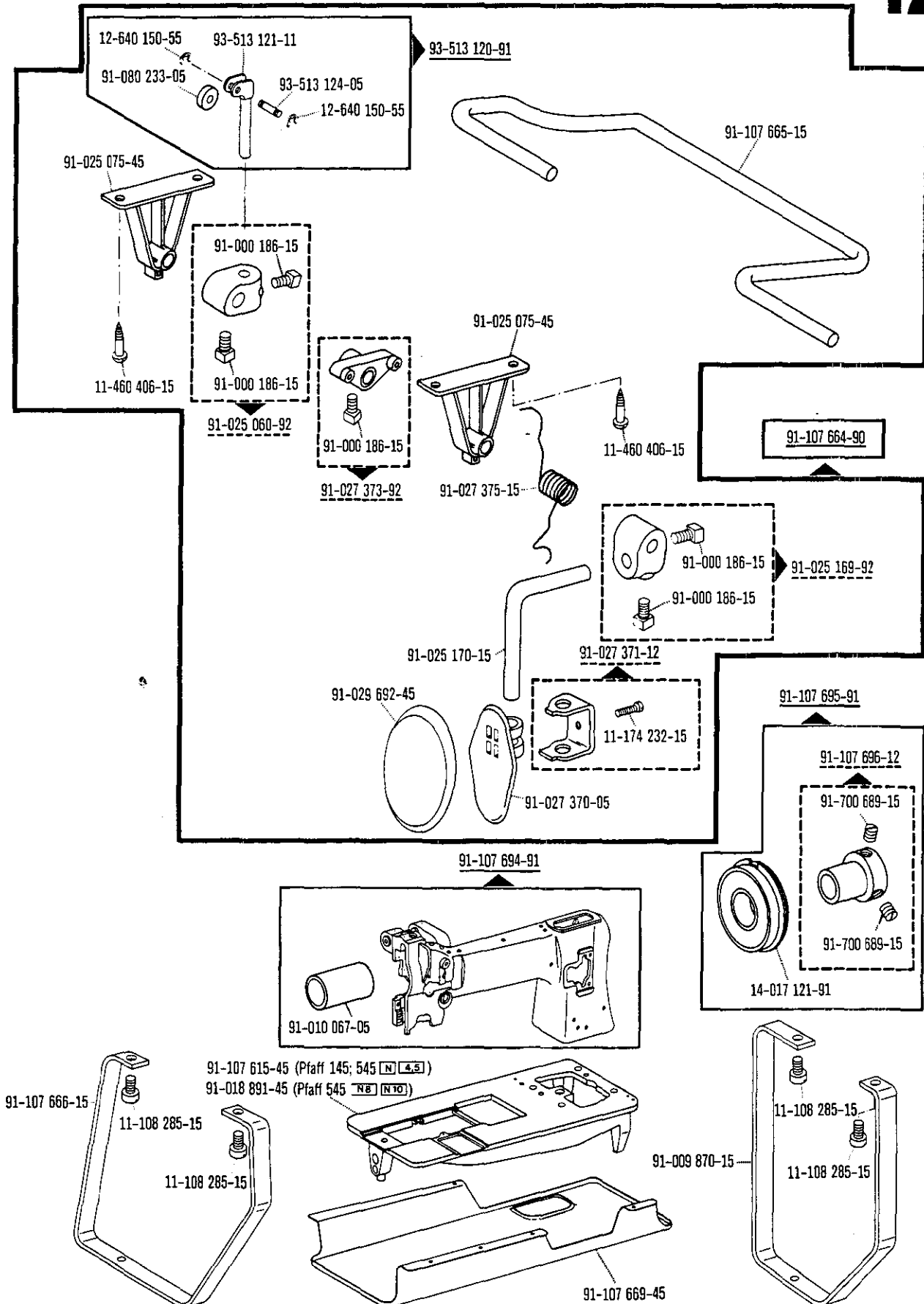

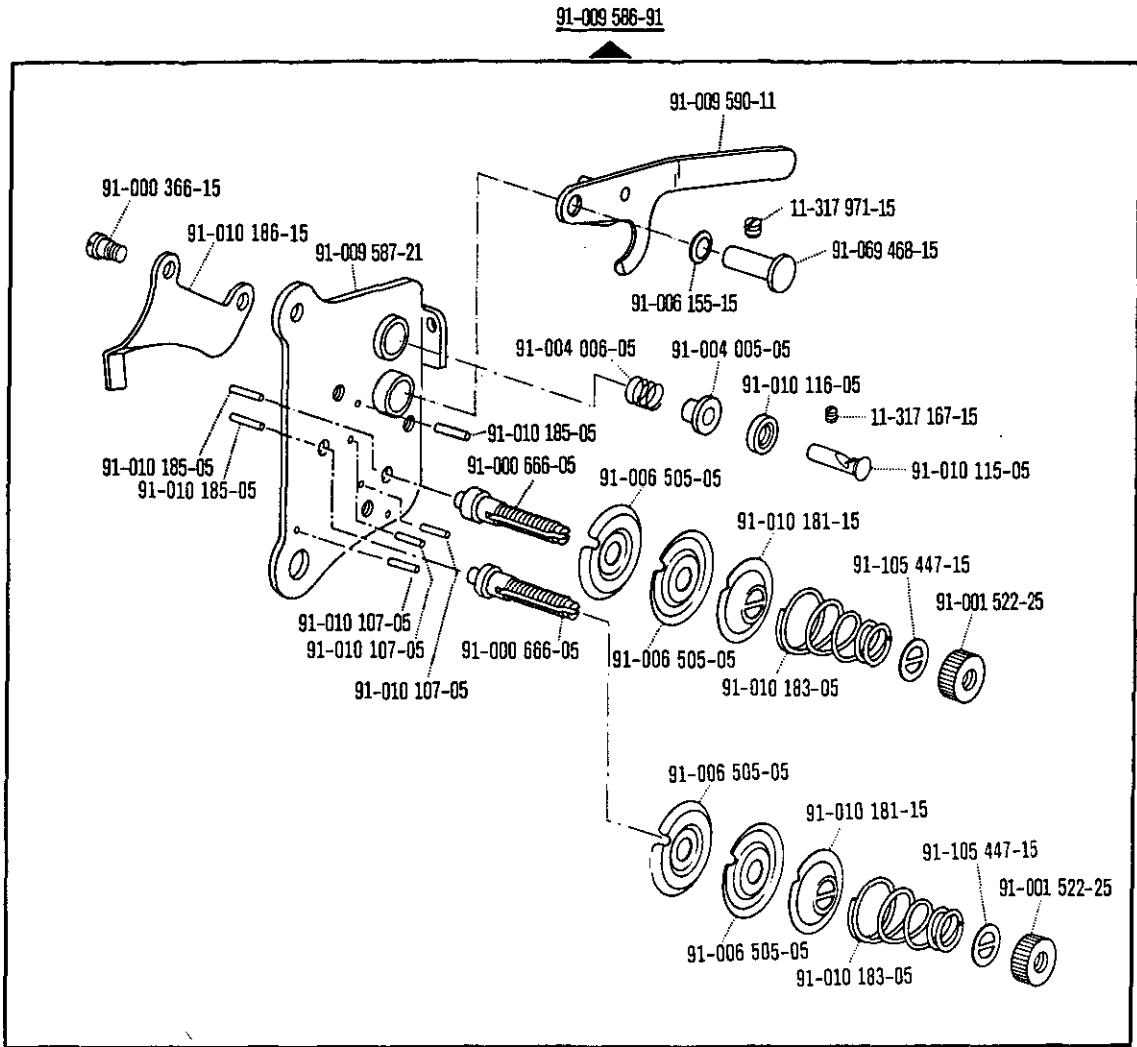

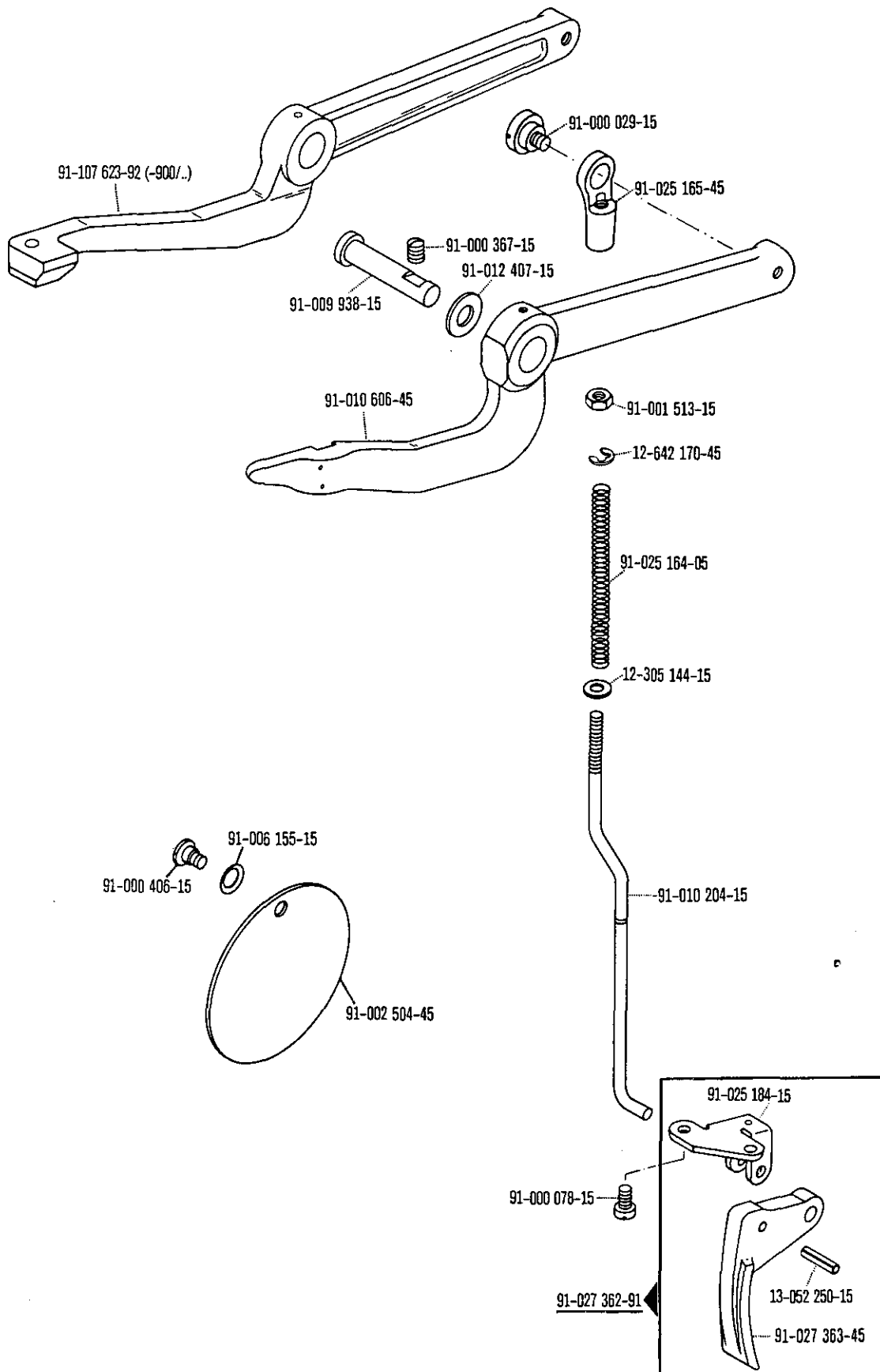

71-59 00-0242 (Quick-PFA 54)

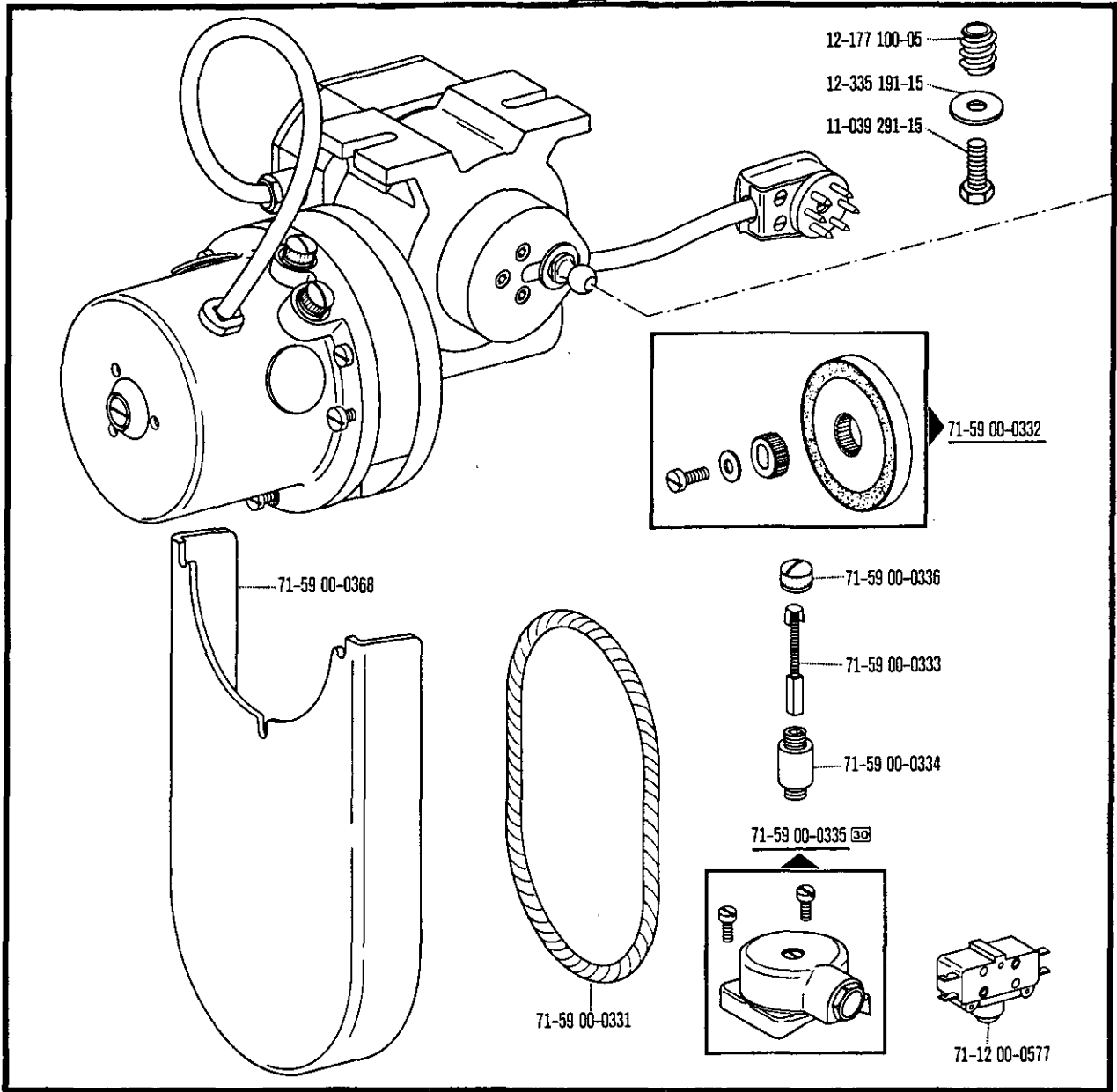

71-59 00-0265 (Quick)

71-59 00-0264 (Pfaff)

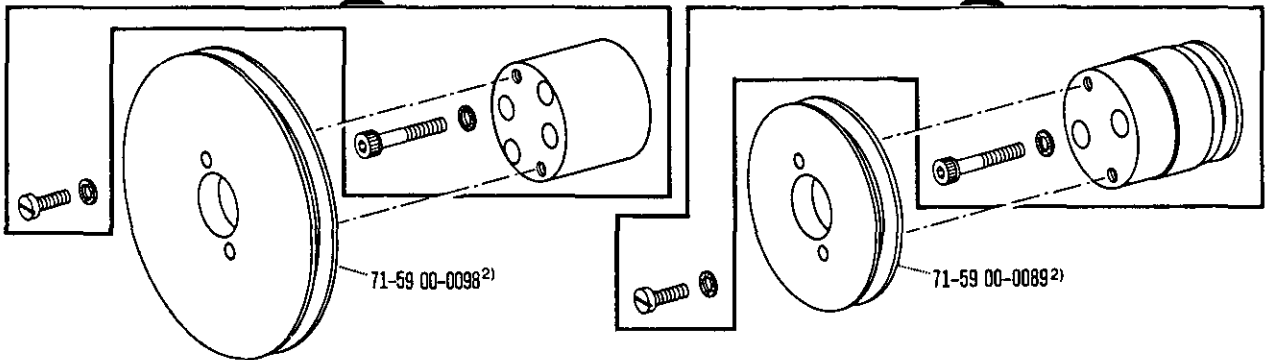

²⁾ Siehe Schnurscheiben-Tabelle Seite 63
see Table of pulleys on page 63

☒ siehe Erläuterungen Seite 5
see explanations on page 7
voir légende page 9

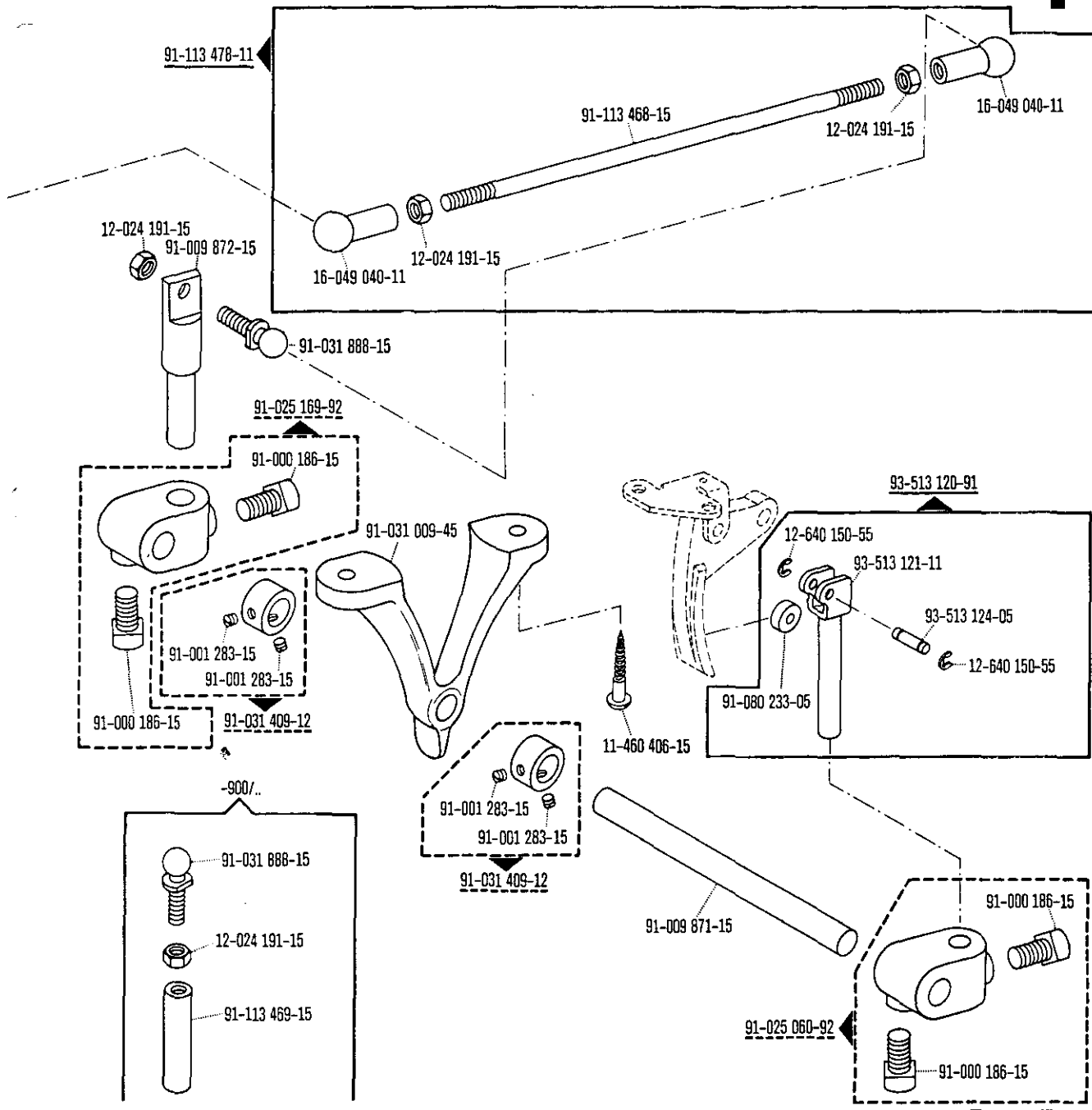

Schnurscheiben-Tabelle · Table of Pulleys

Tableau des poulies à gorge · Tabla de poleas acanaladas

Teilenummer Part number Numéros des pièces № de las piezas	Motordrehzahl U/min. Motor speed (r. p. m.) Régime moteur trs/mn Régimen del motor en r. p. m.	Frequenz Frequency Fréquence Frecuencia	Schnurscheiben-Durchmesser ¹⁾ in mm Pulley dia. ¹⁾ (mm) Diamètre effectif de la poulie en mm Diámetro efectivo de la polea en mm
71-59 00-0098	1400	50 Hz (c/s)	86
	1700	60 Hz (c/s)	86
71-59 00-0089	2800	50 Hz (c/s)	56
	3400	60 Hz (c/s)	56

00-000 000-00 00-000 000-00 00-000 000-00 siehe Erläuterungen Seite 5
see explanations on page 7
voir légende page 9

¹⁾ Wirksamer Durchmesser
Effective diameter
Diamètre effectif
Diámetro efectivo

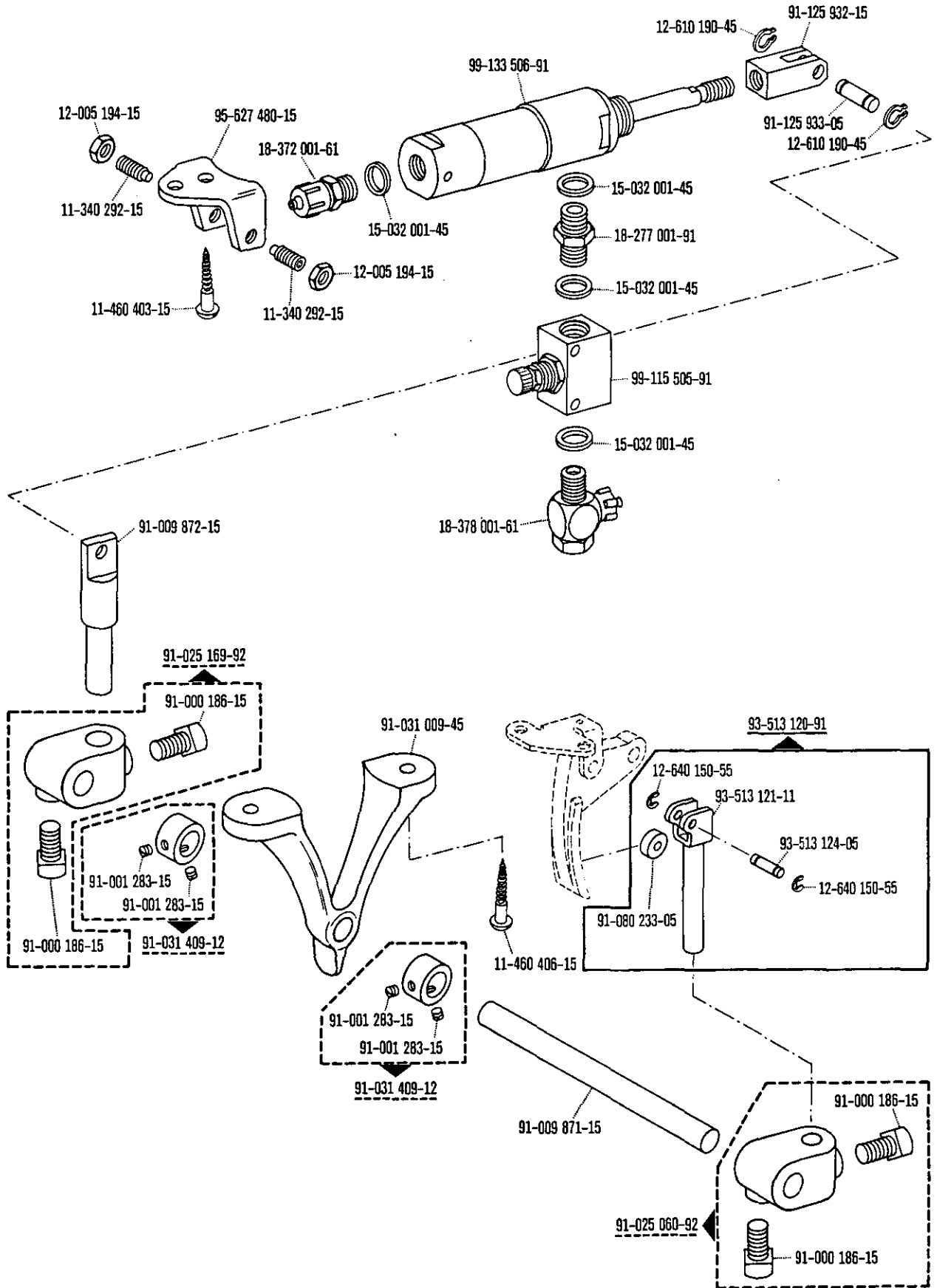

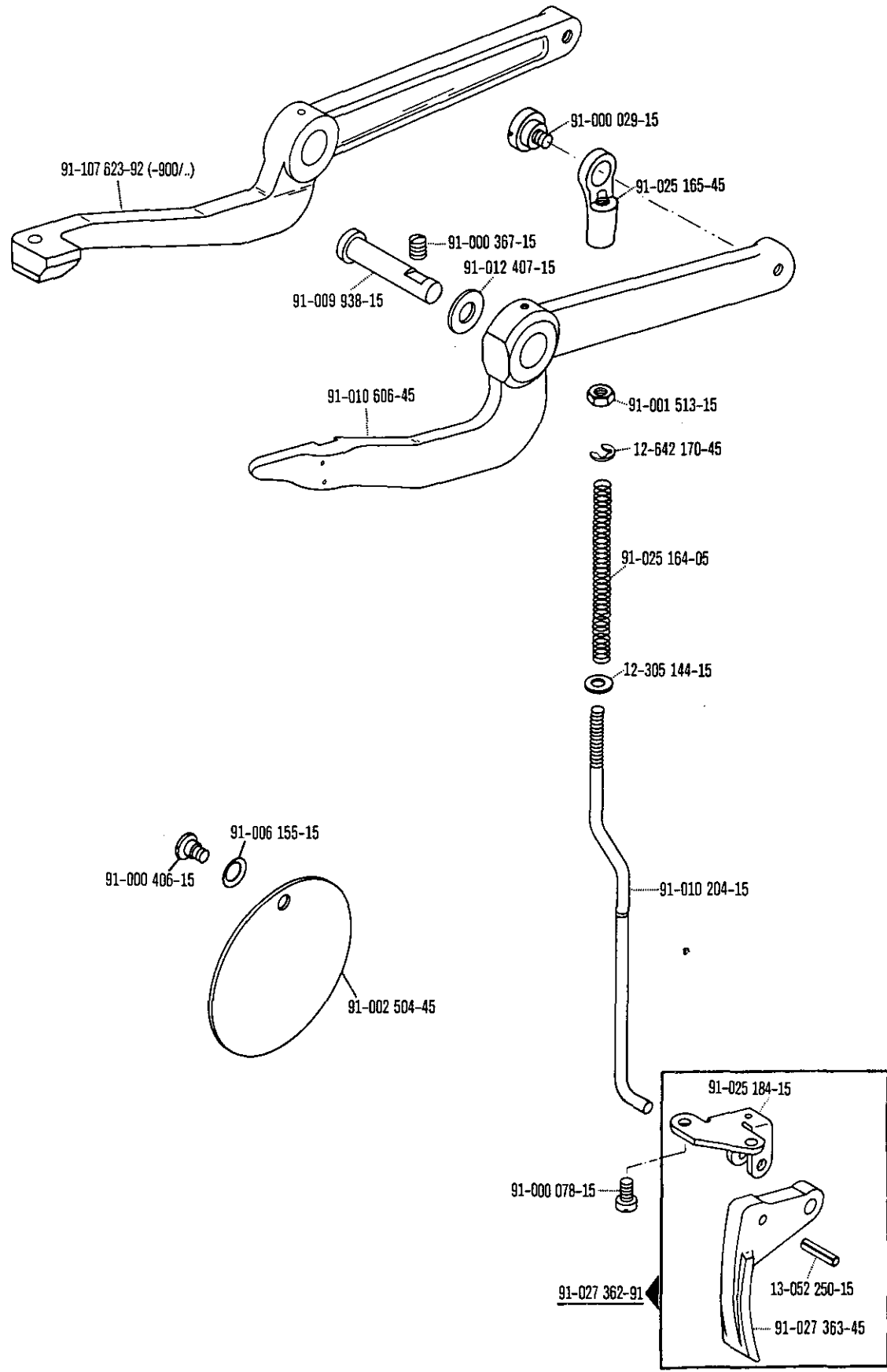

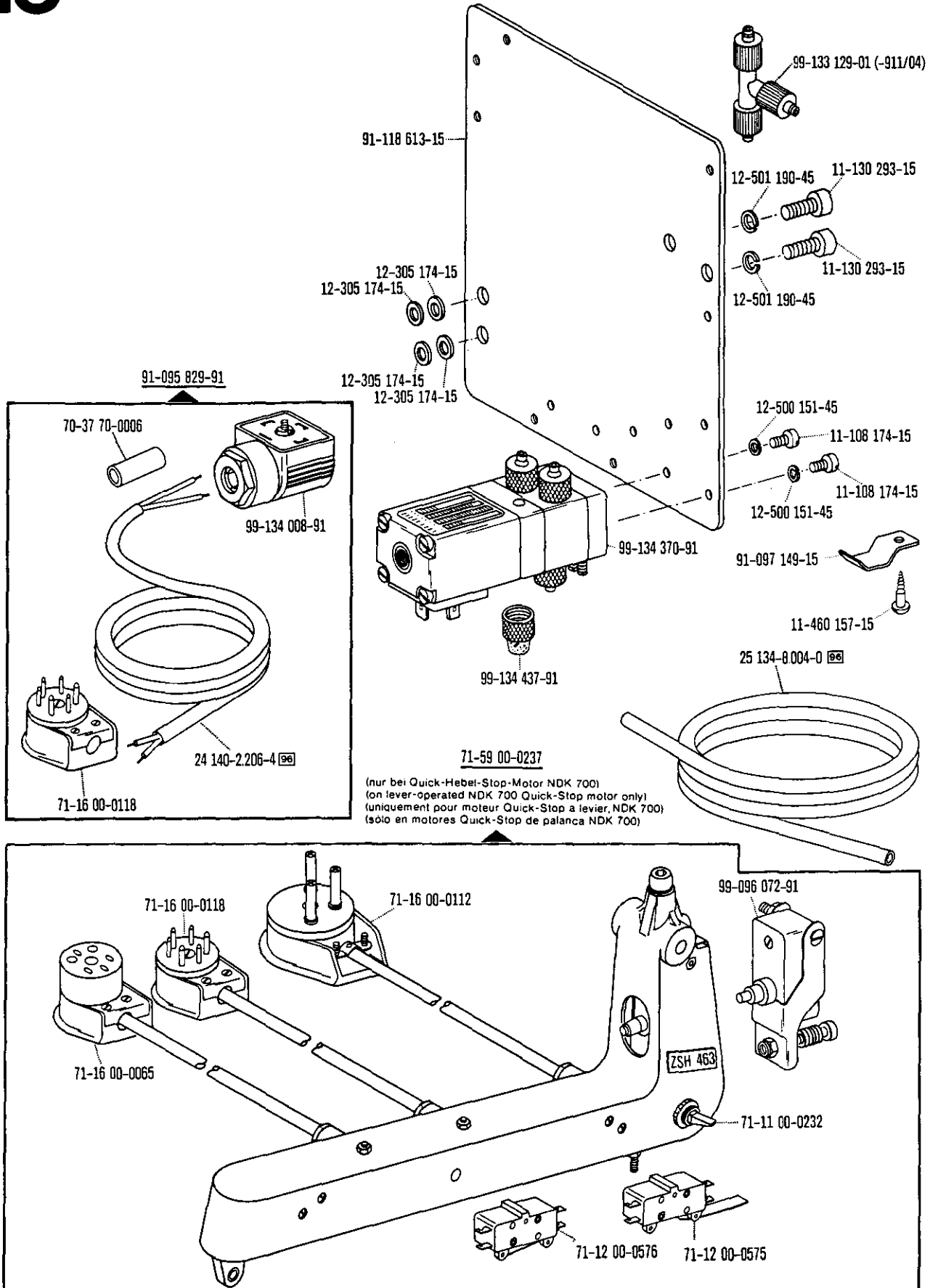

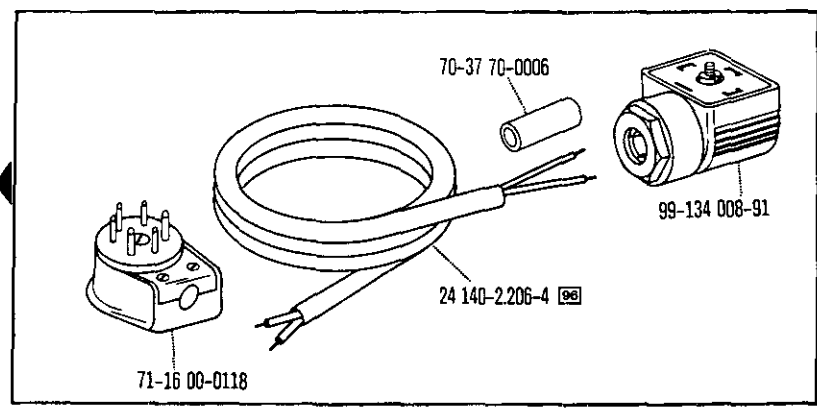
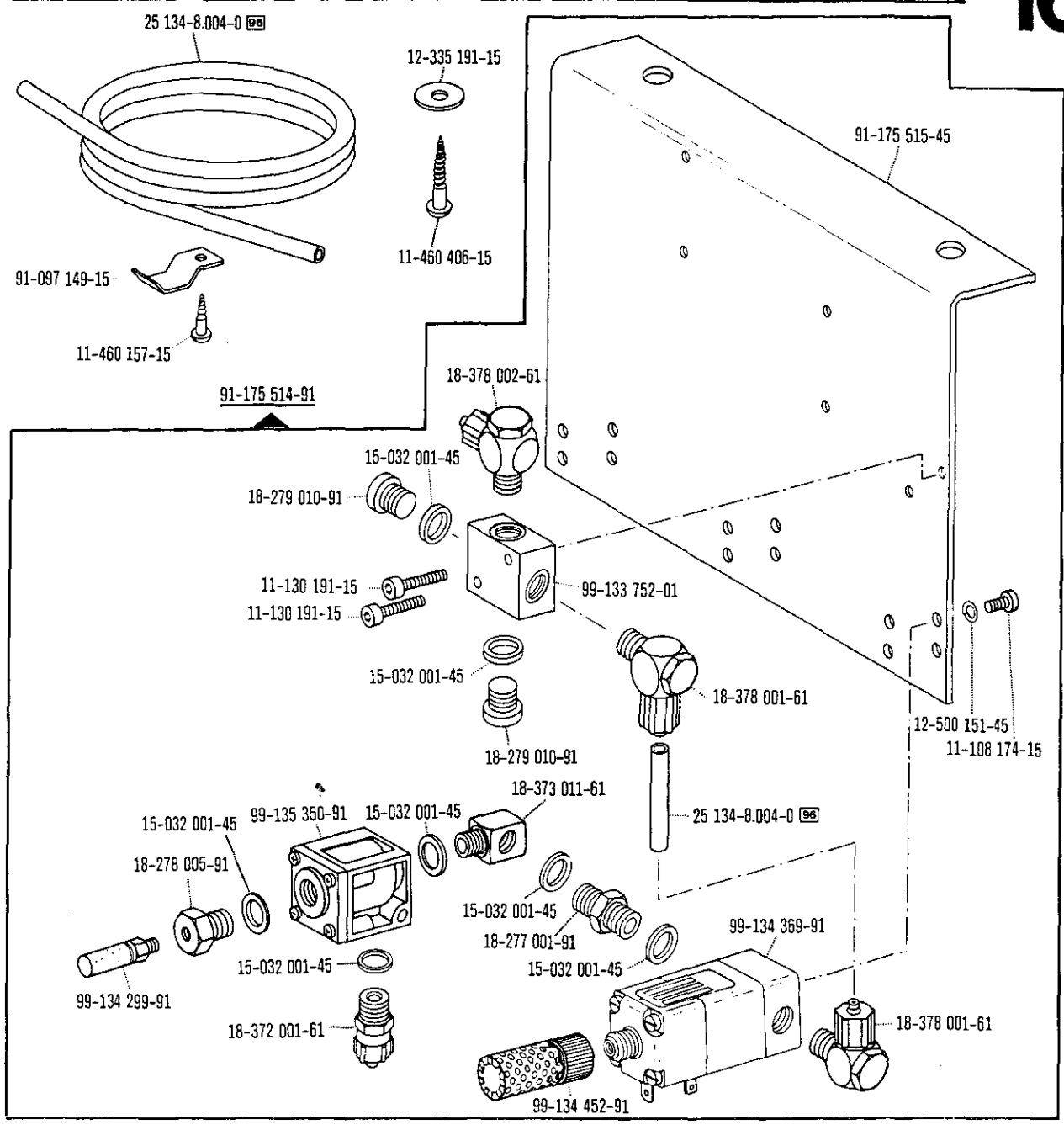

00-000 000-00 00-000 000-00 00-000 000-00 siehe Erläuterungen Seite 5
see explanations on page 7
voir légende page 9

(nur bei Quick-Hebel-Stop-Motor NDK 700)
(on lever-operated NDK 700 Quick-Stop motor only)
(uniquement pour moteur Quick-Stop à levier, NDK 700)
(solo en motores Quick-Stop de palanca NDK 700)

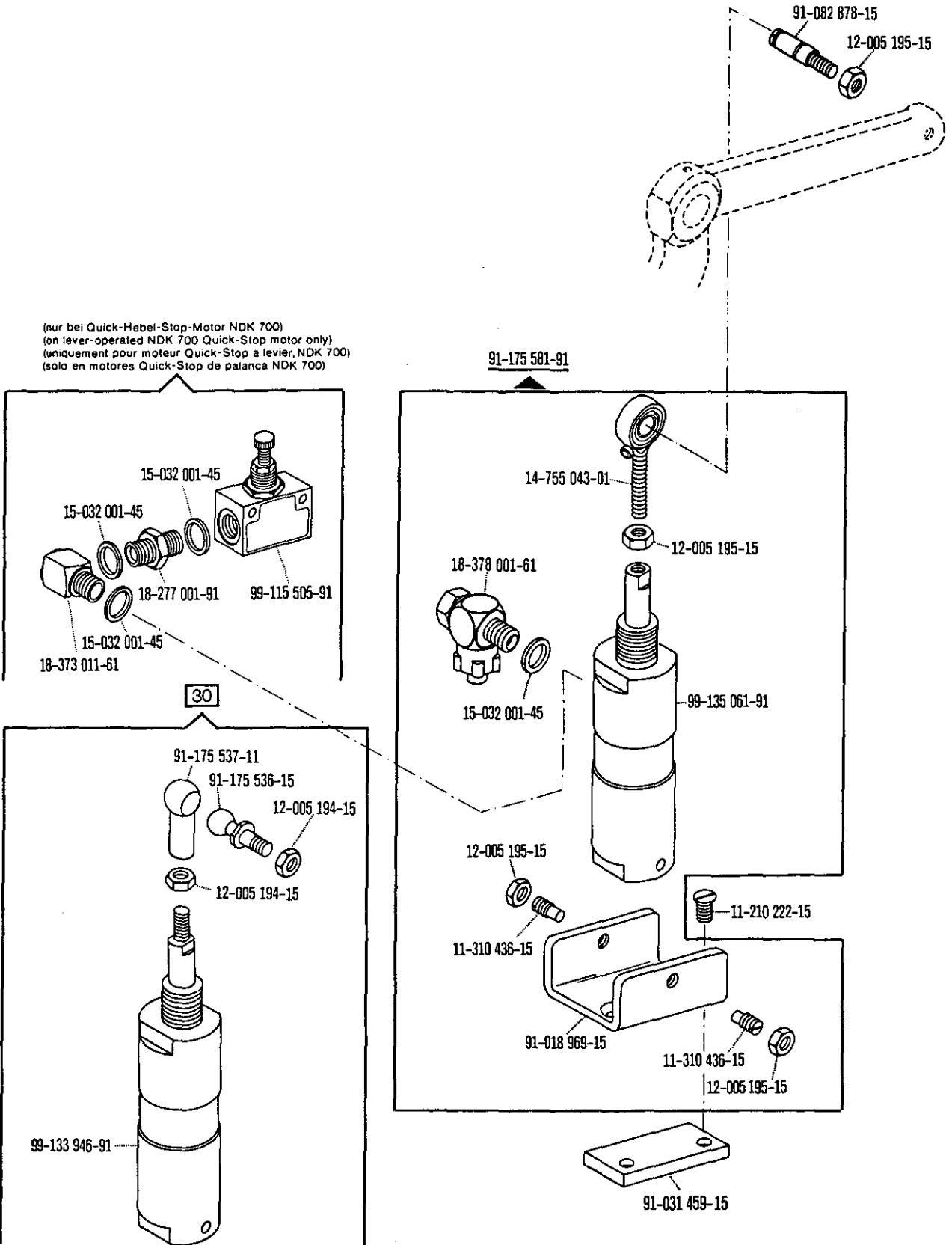

Entfällt bei Pfaff 545 B und 545-900/..
Omitted on Pfaff 545 B and 545-900/..
Supprimé sur la Pfaff 545 B et 545-900/..
Suprimido en la Pfaff 545 B y 545-900/..

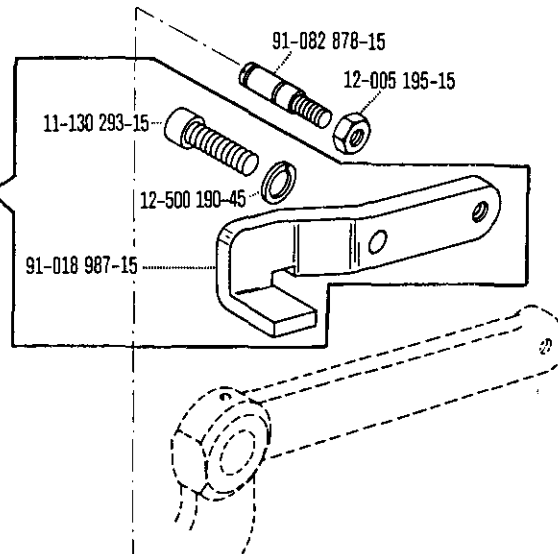
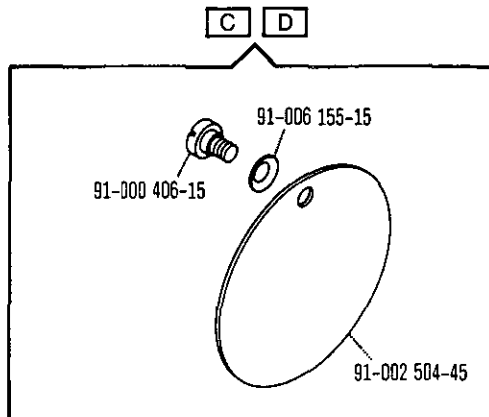

(nur bei Quick-Hebel-Stop-Motor NDK 700)
(on lever-operated NDK 700 Quick-Stop motor only)
(uniquement pour moteur Quick-Stop a levier NDK 700)
(solo en motores Quick-Stop de palanca NDK 700)

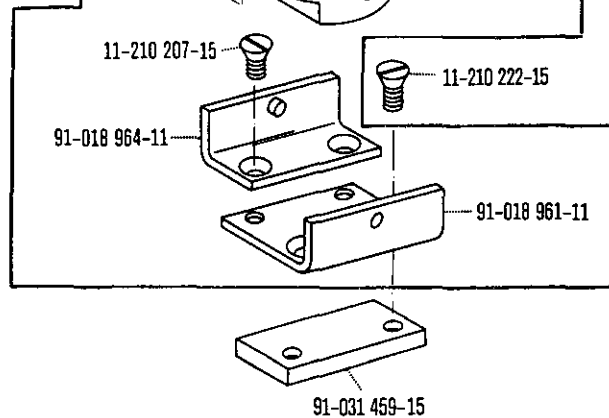
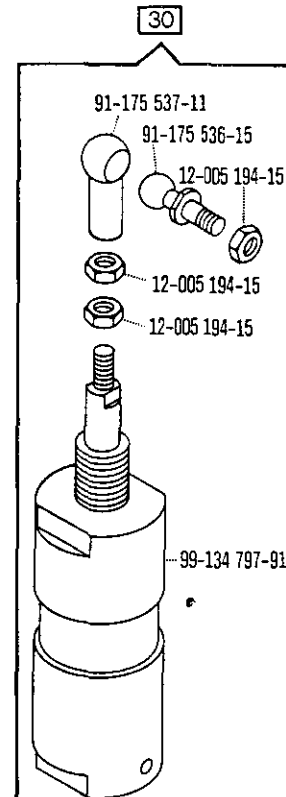
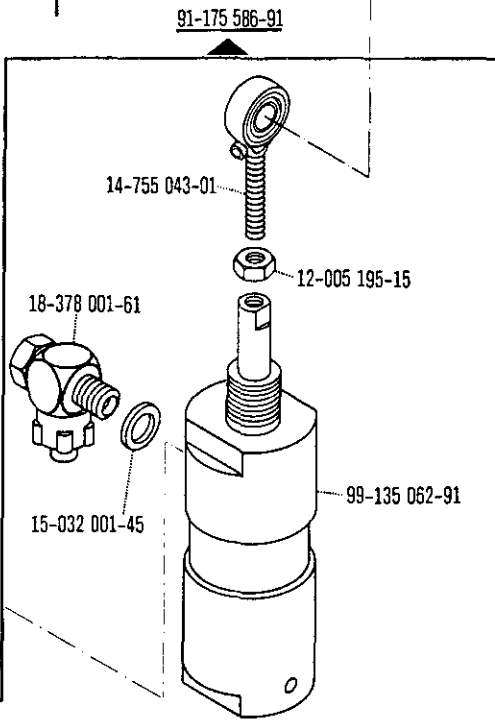
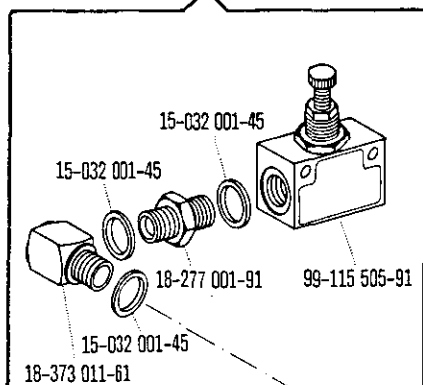

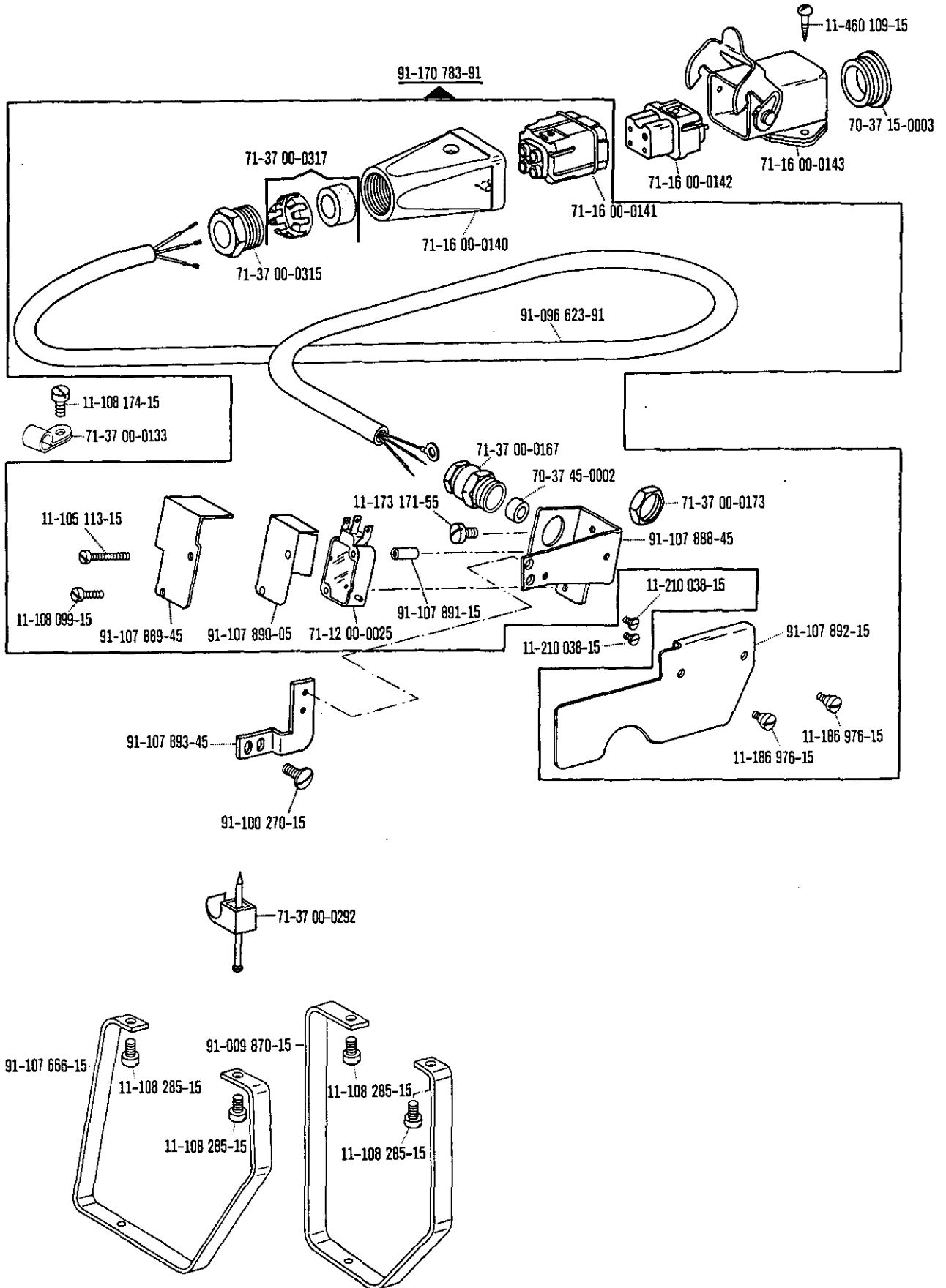

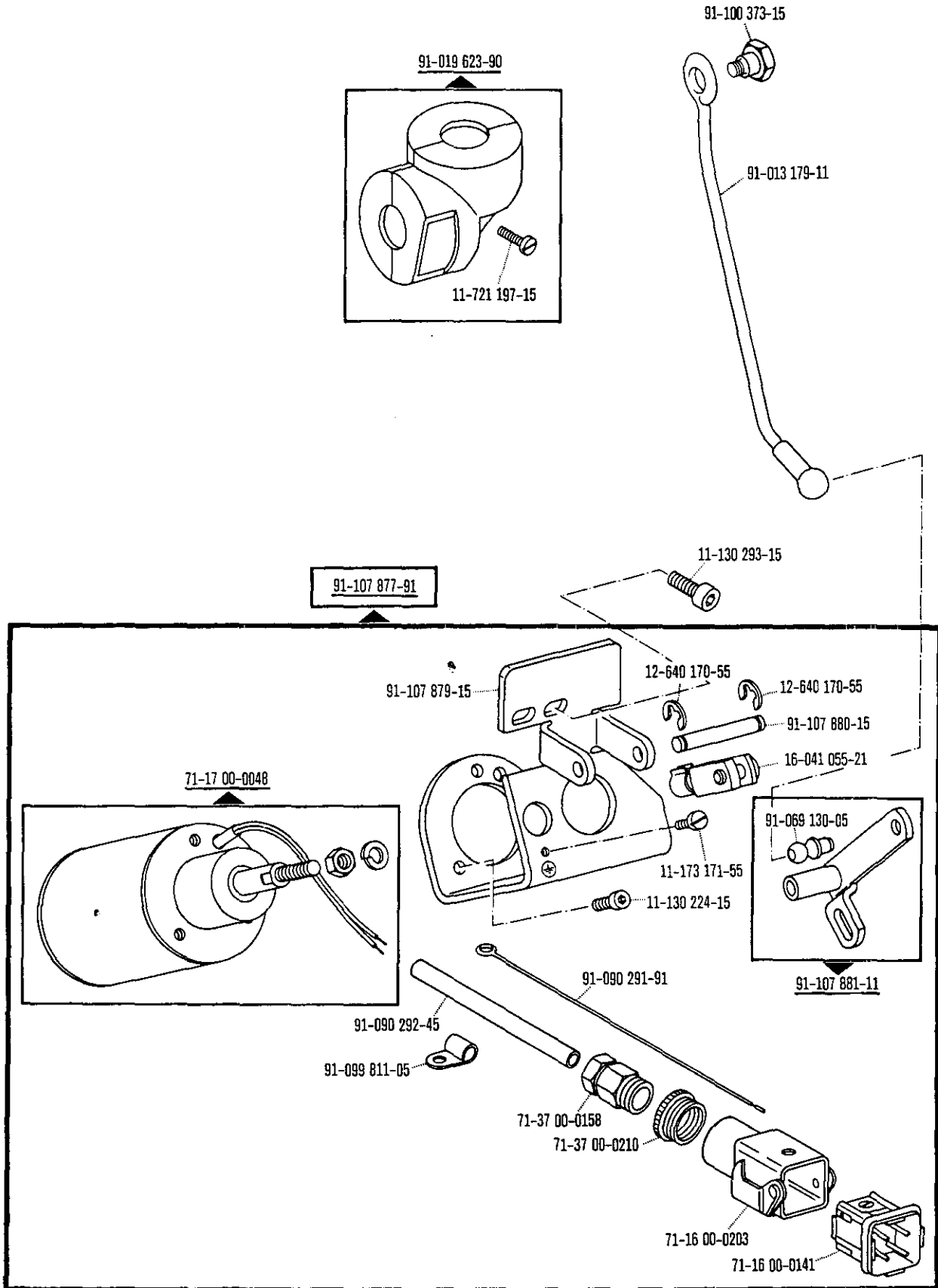

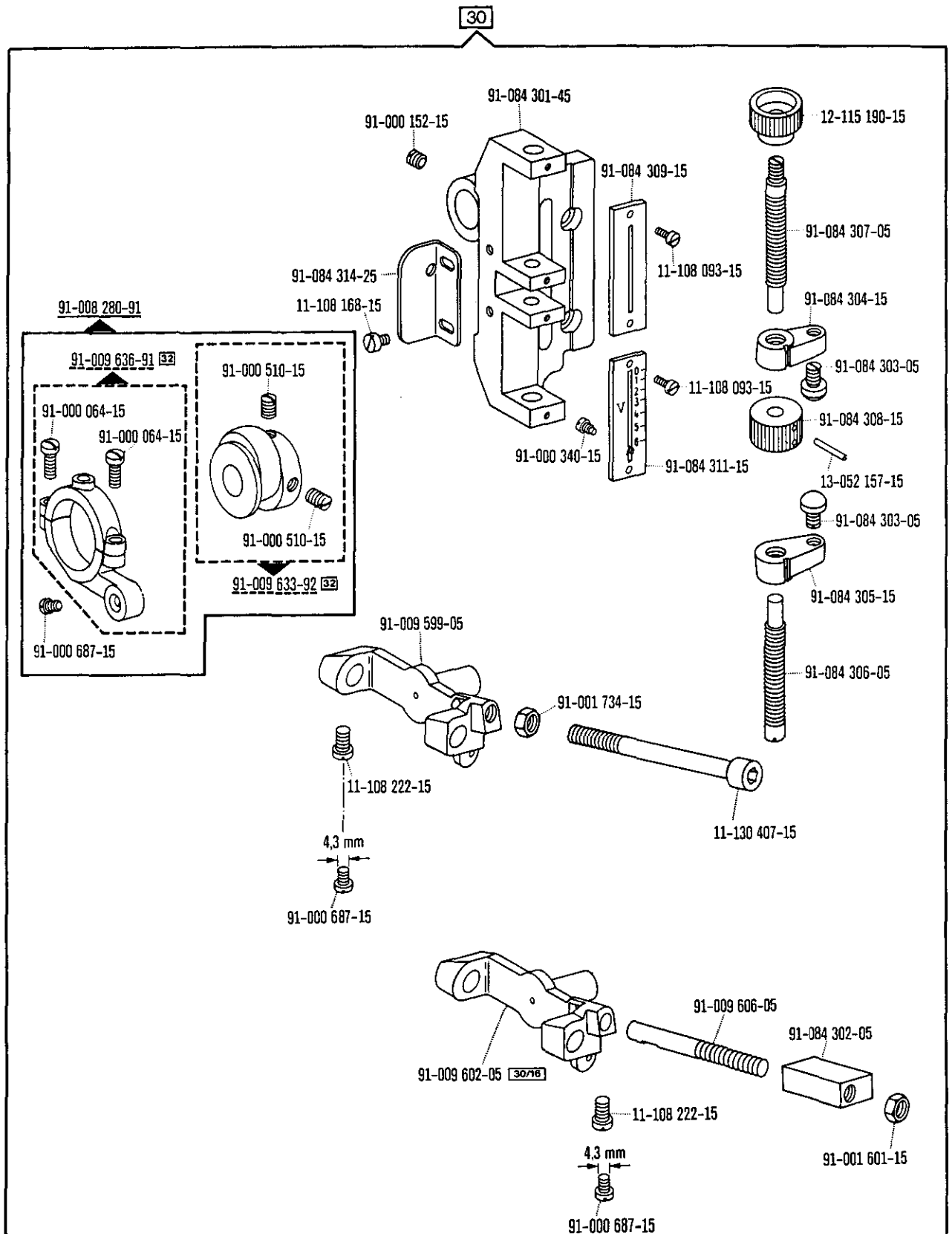

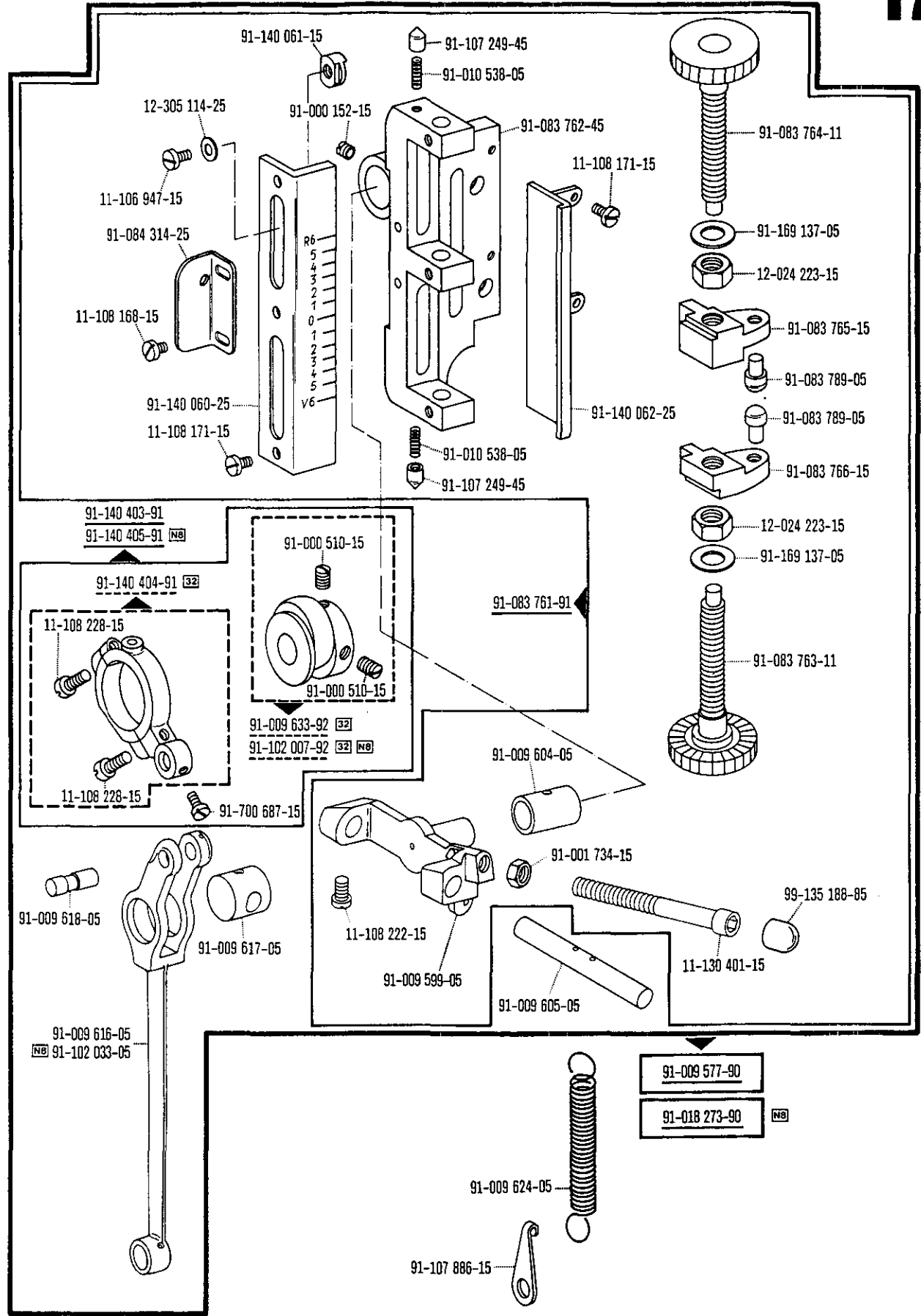

00-000 000-00 00-000 000-00 00-000 000-00 00-000 000-00 (NB) (32)

siehe Erläuterungen Seite 5
see explanations on page 7
voir légende page 9

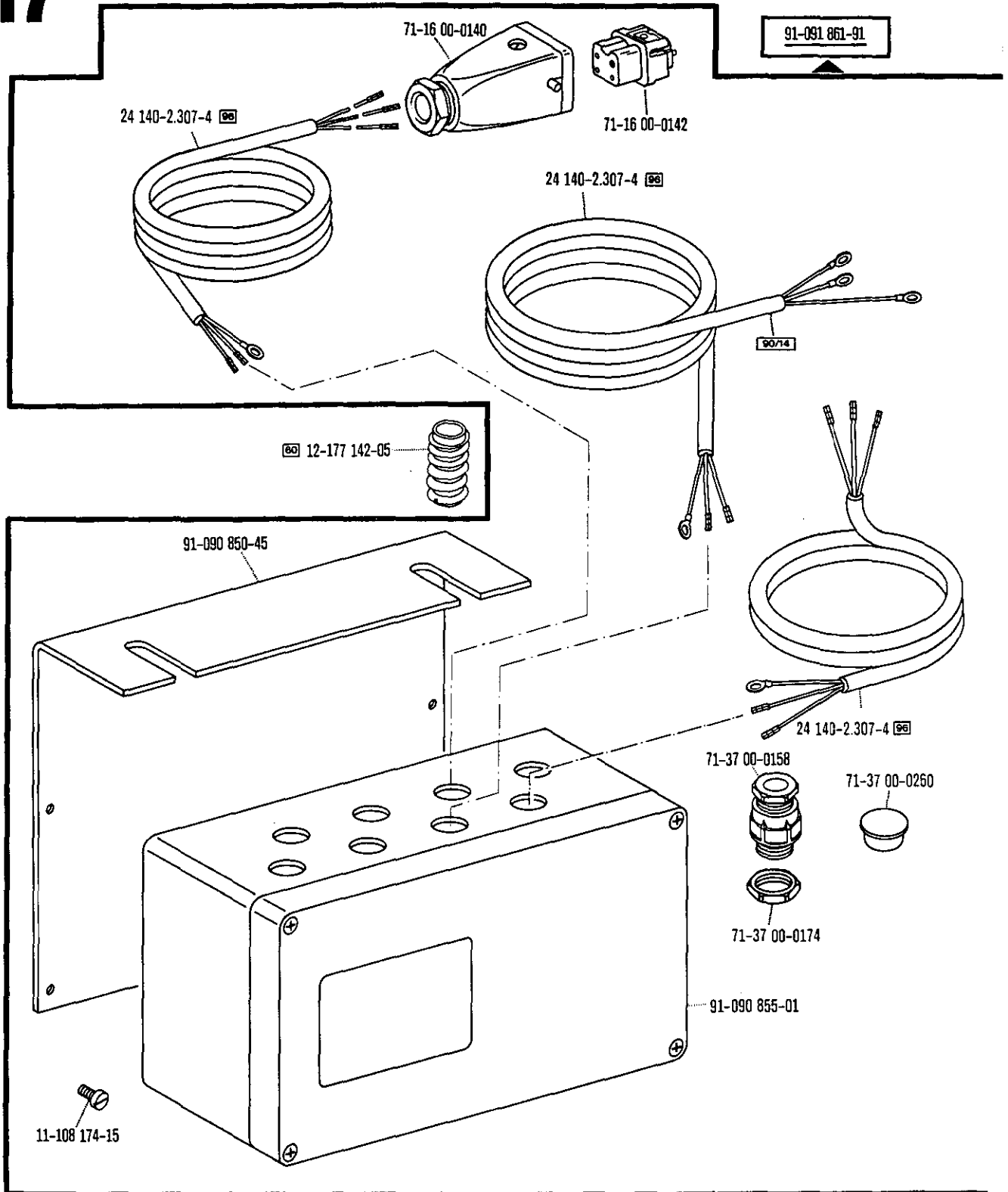

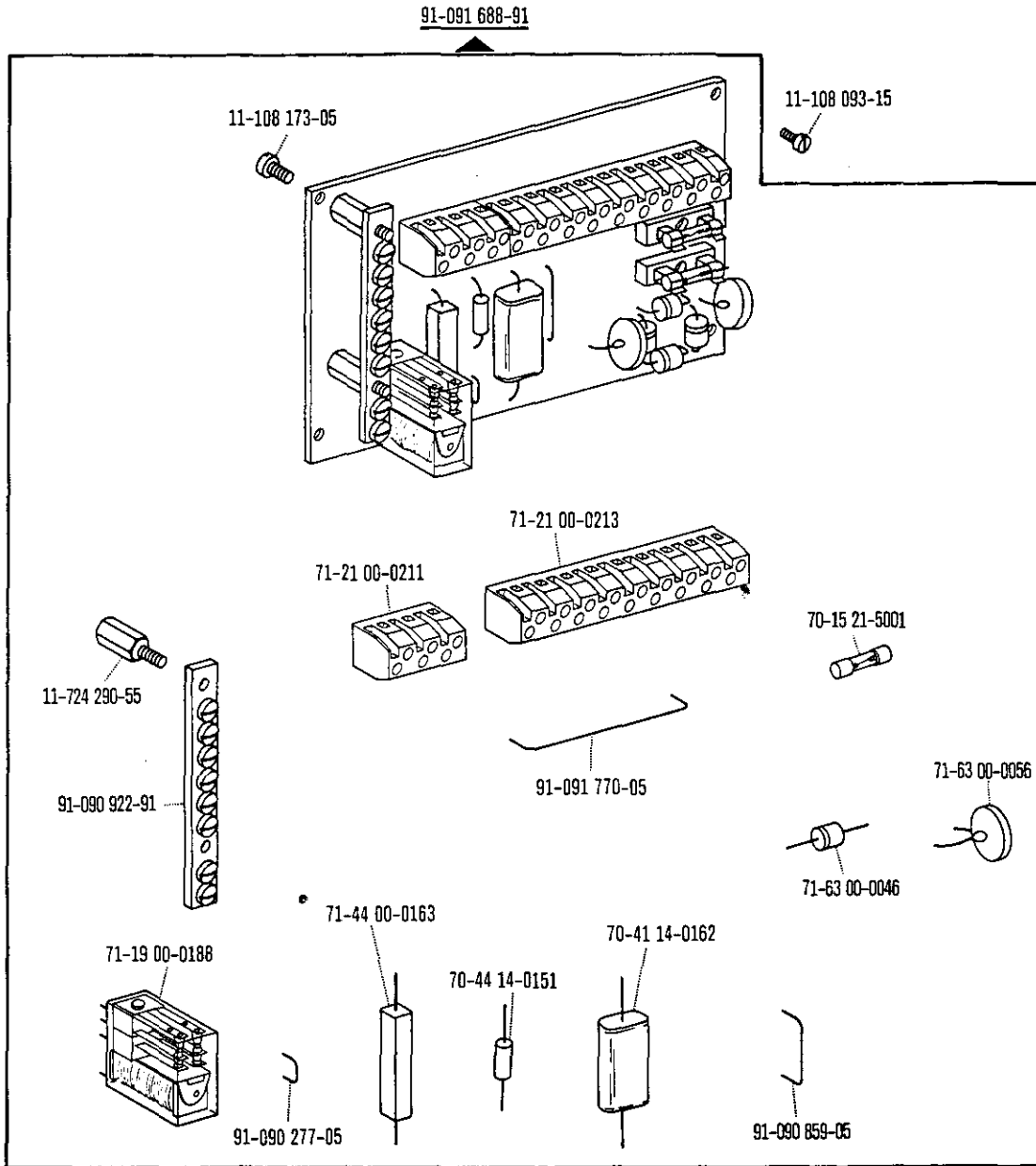

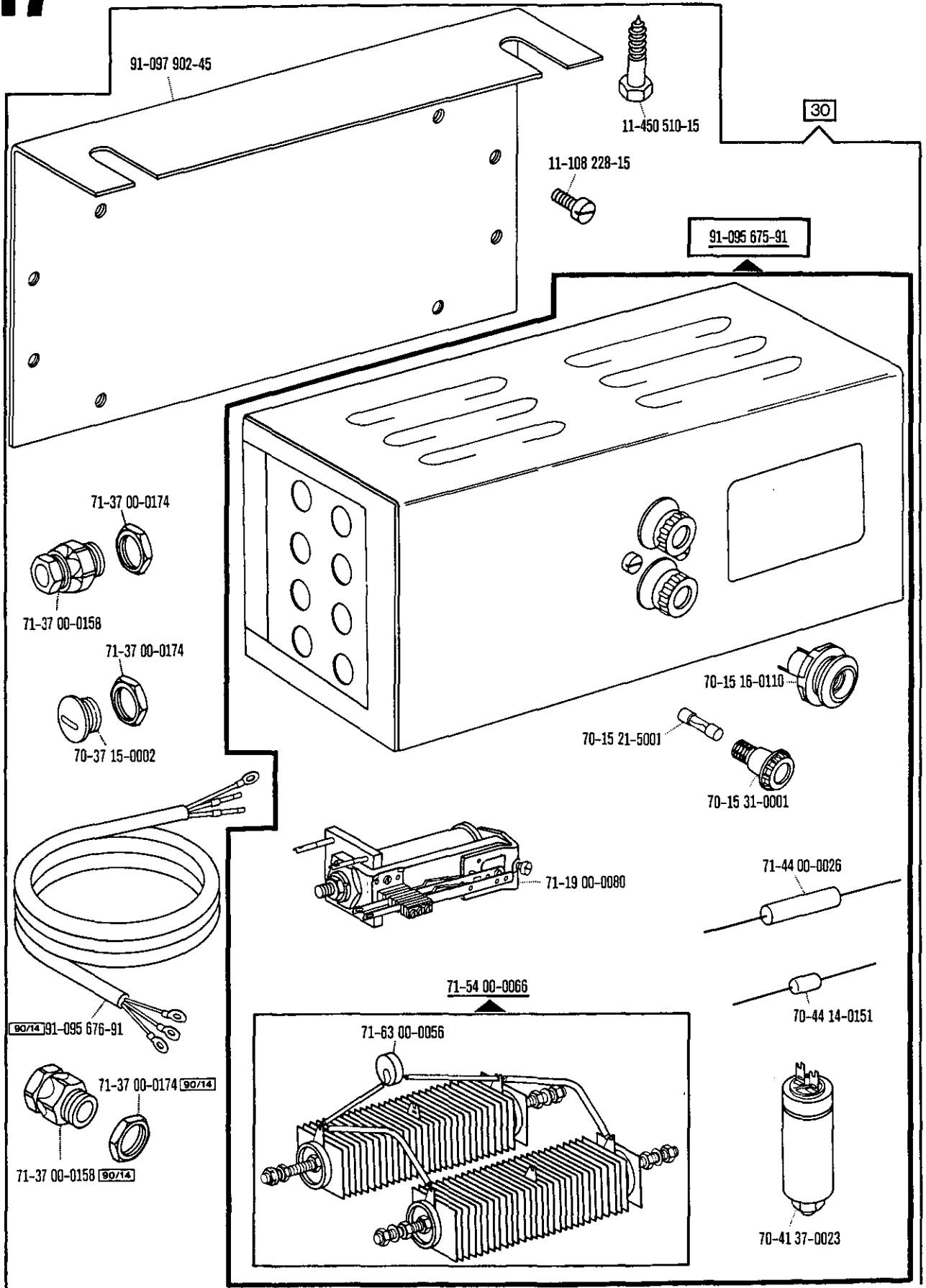

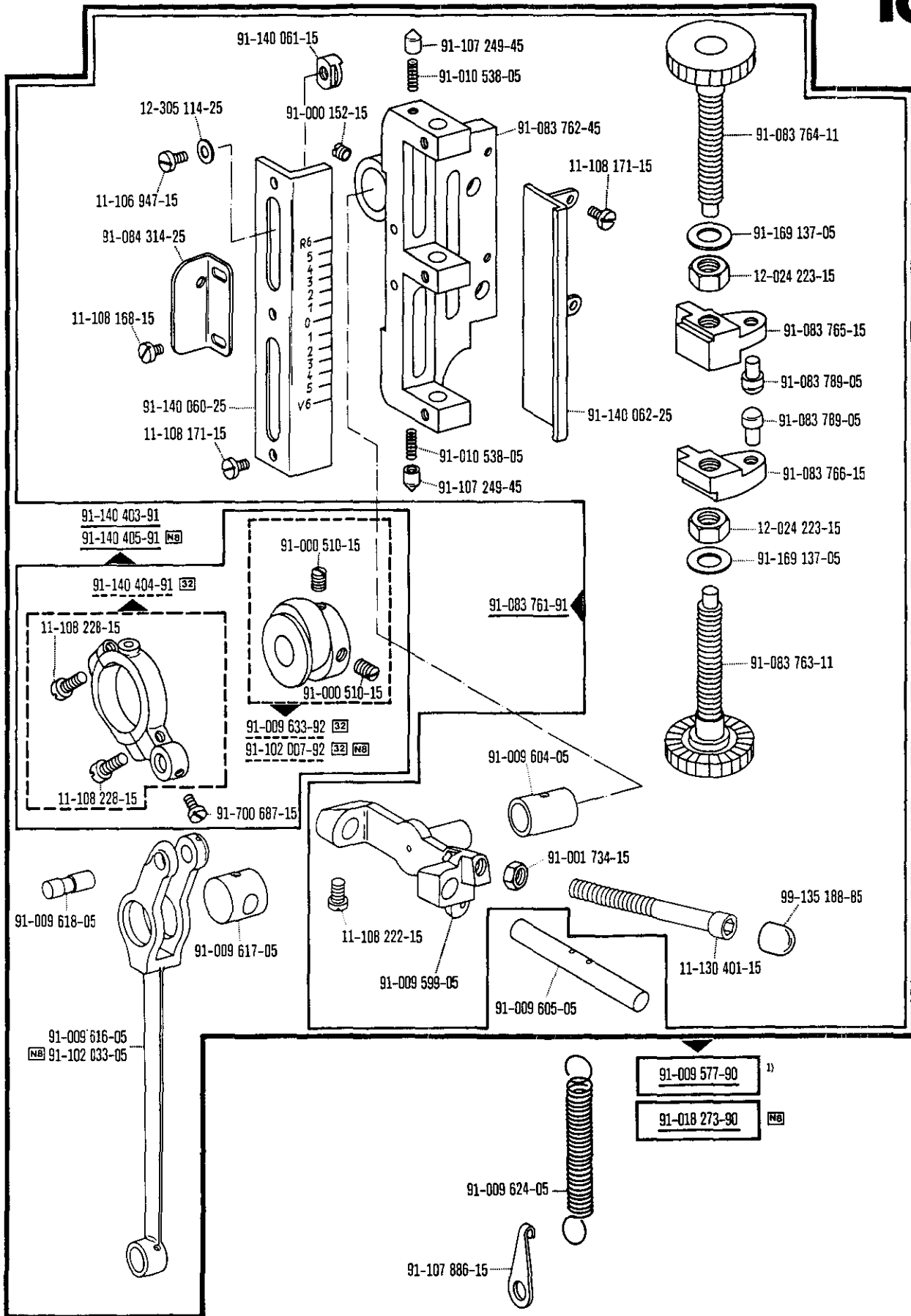

00-000 000-00 00-000 000-00 00-000 000-00 00-000 000-00 (NB) (32) siehe Erläuterungen Seite 5
 see explanations on page 7
 voir legende page 9

1) Frühere Ausführung siehe Seite 72
 Earlier version, see page 72
 Ancienne version, voir page 72
 Anterior version, see page 72

91-091 585-91 90/11

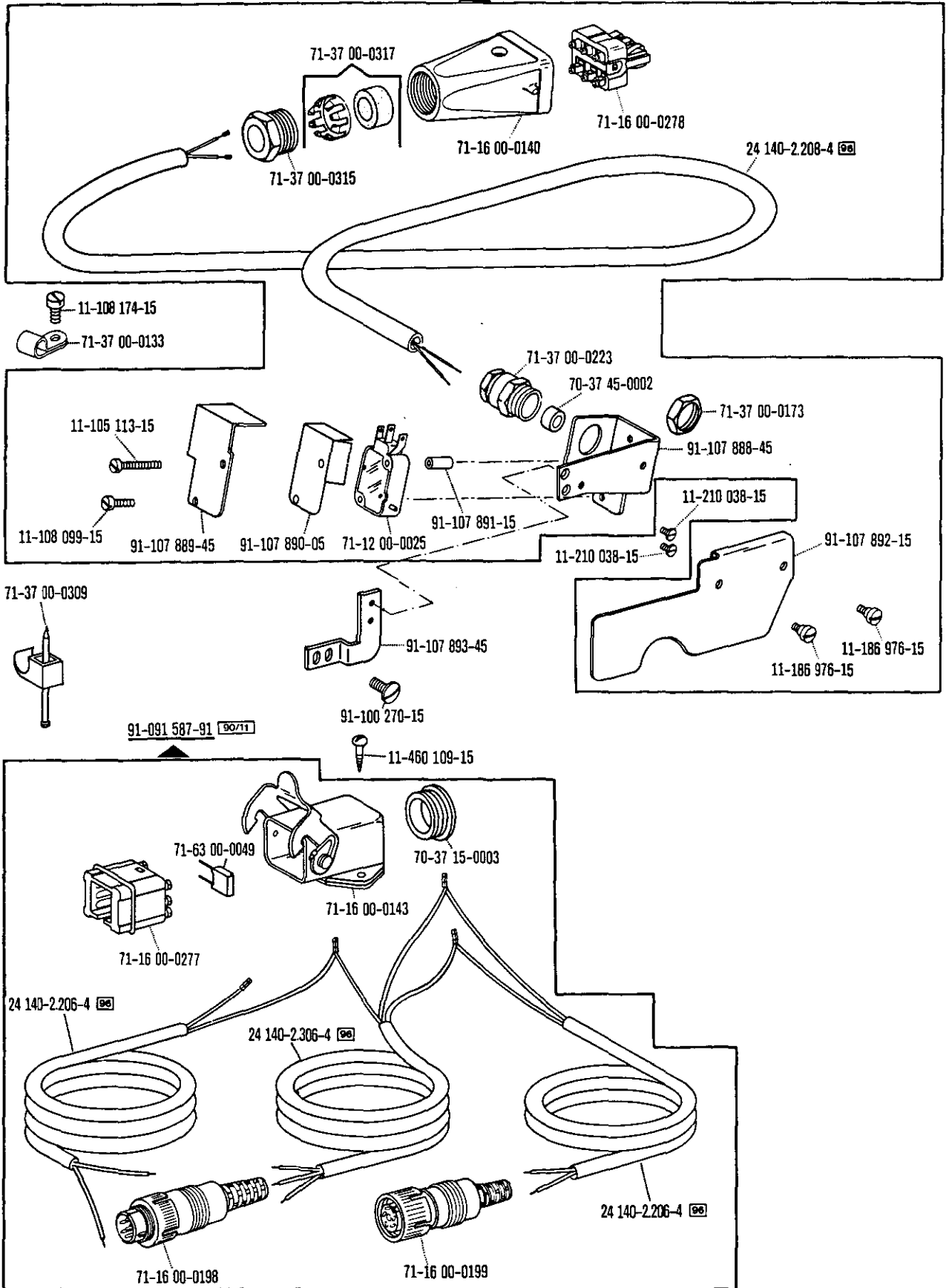

91-091 587-91 90/11

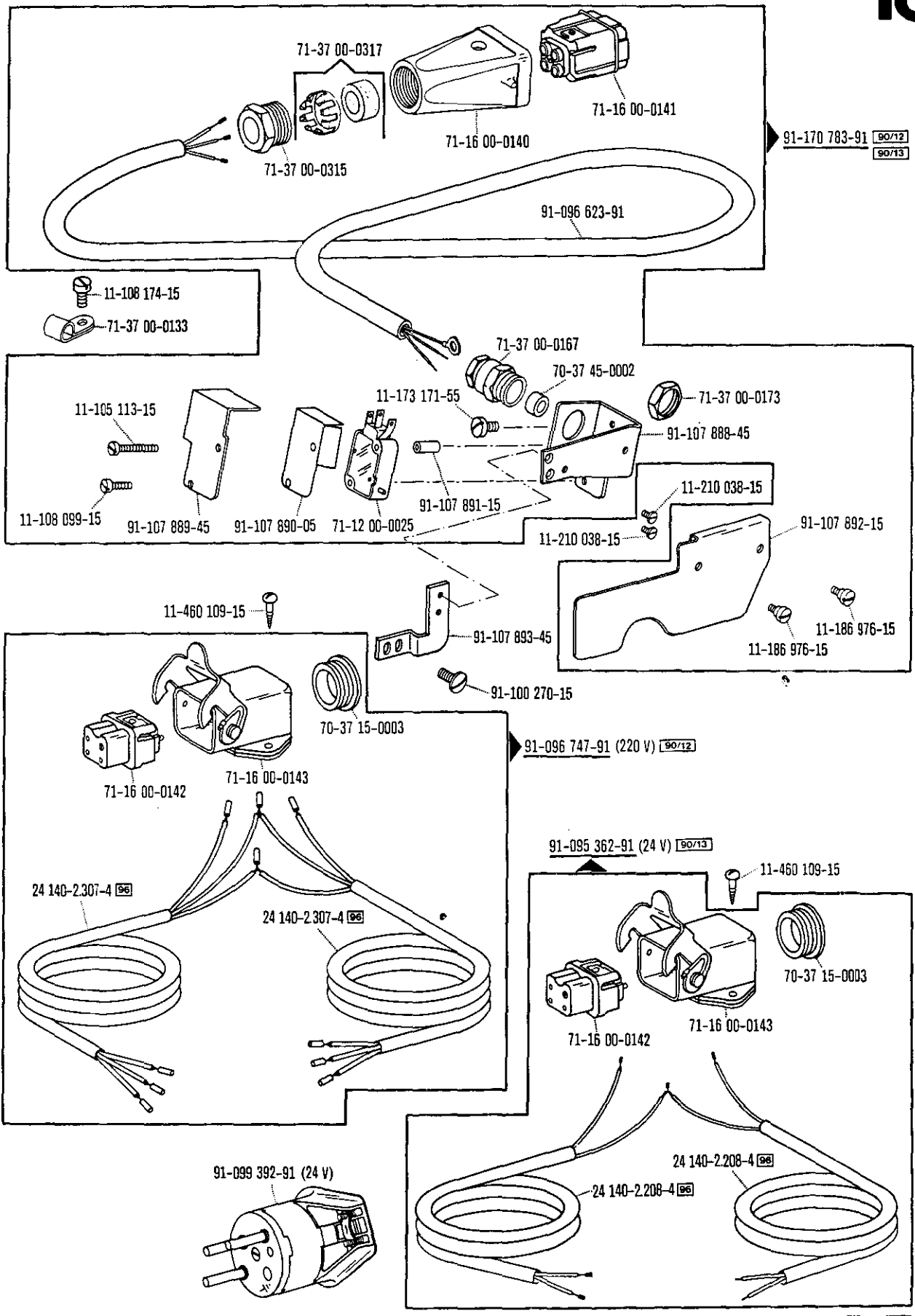

50-000 000-00 00-000 000-00 90/12 90/13 96 Siche Erläuterungen Seite 5
see explanations on page 7
voir légende page 9

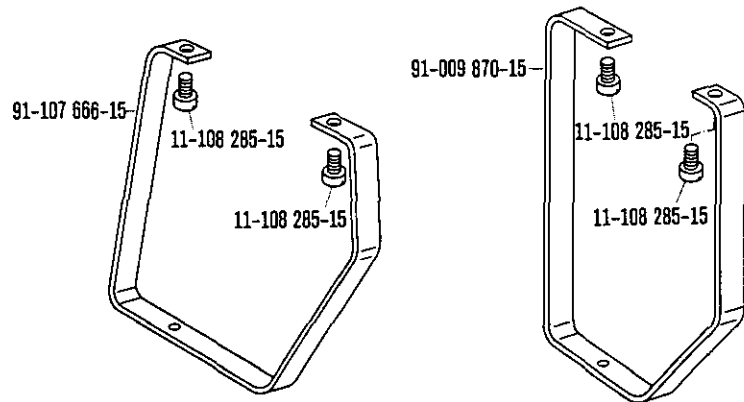
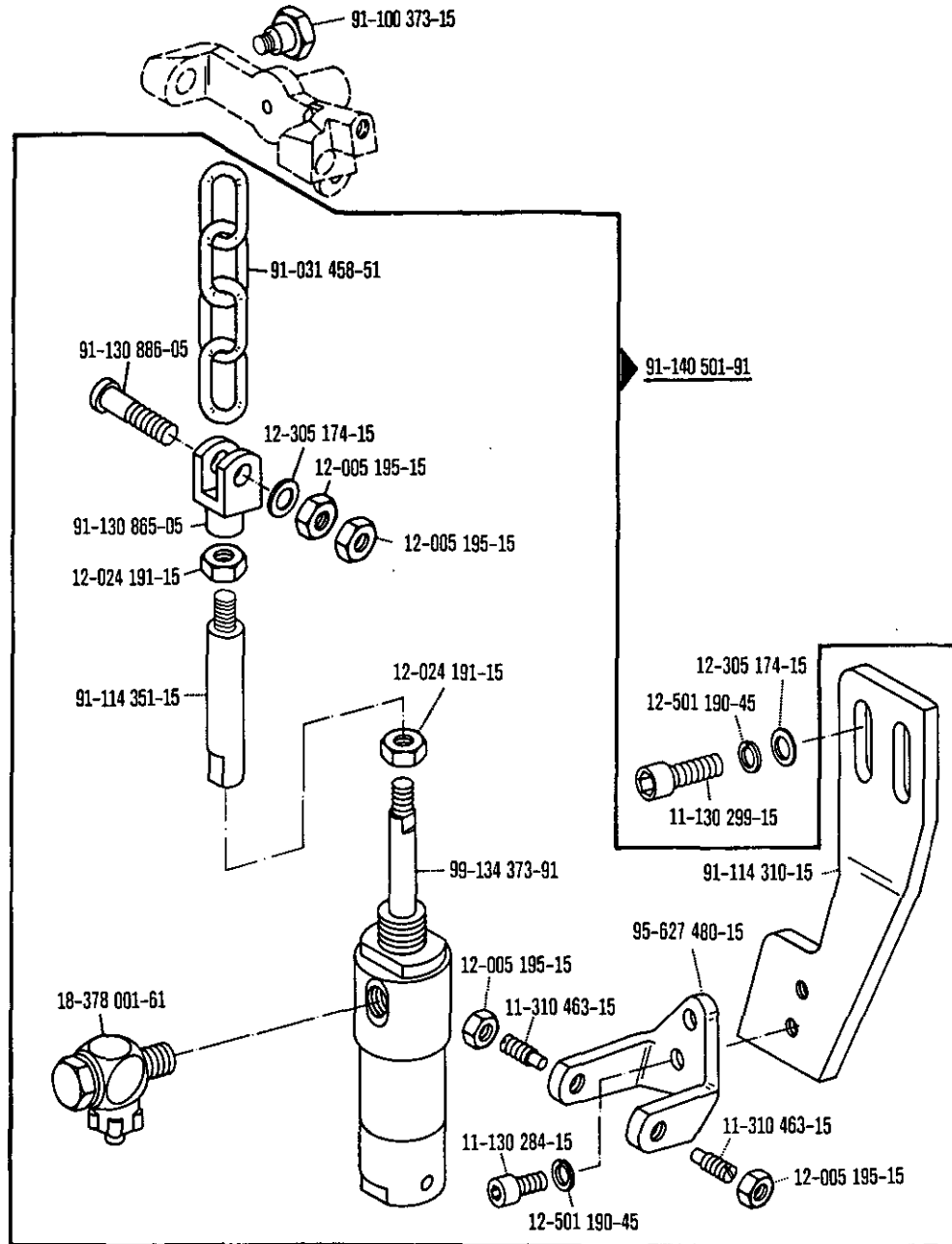

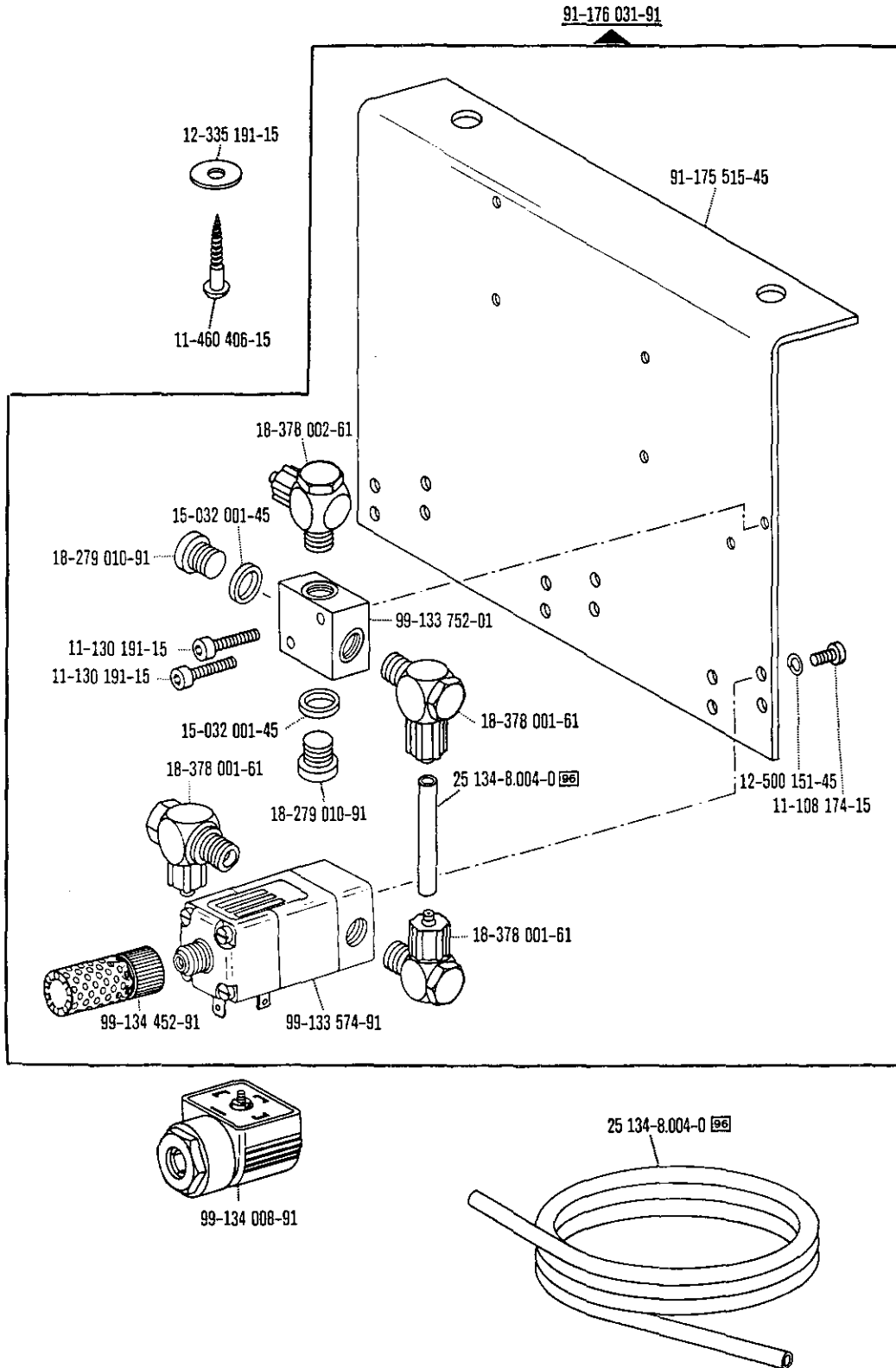

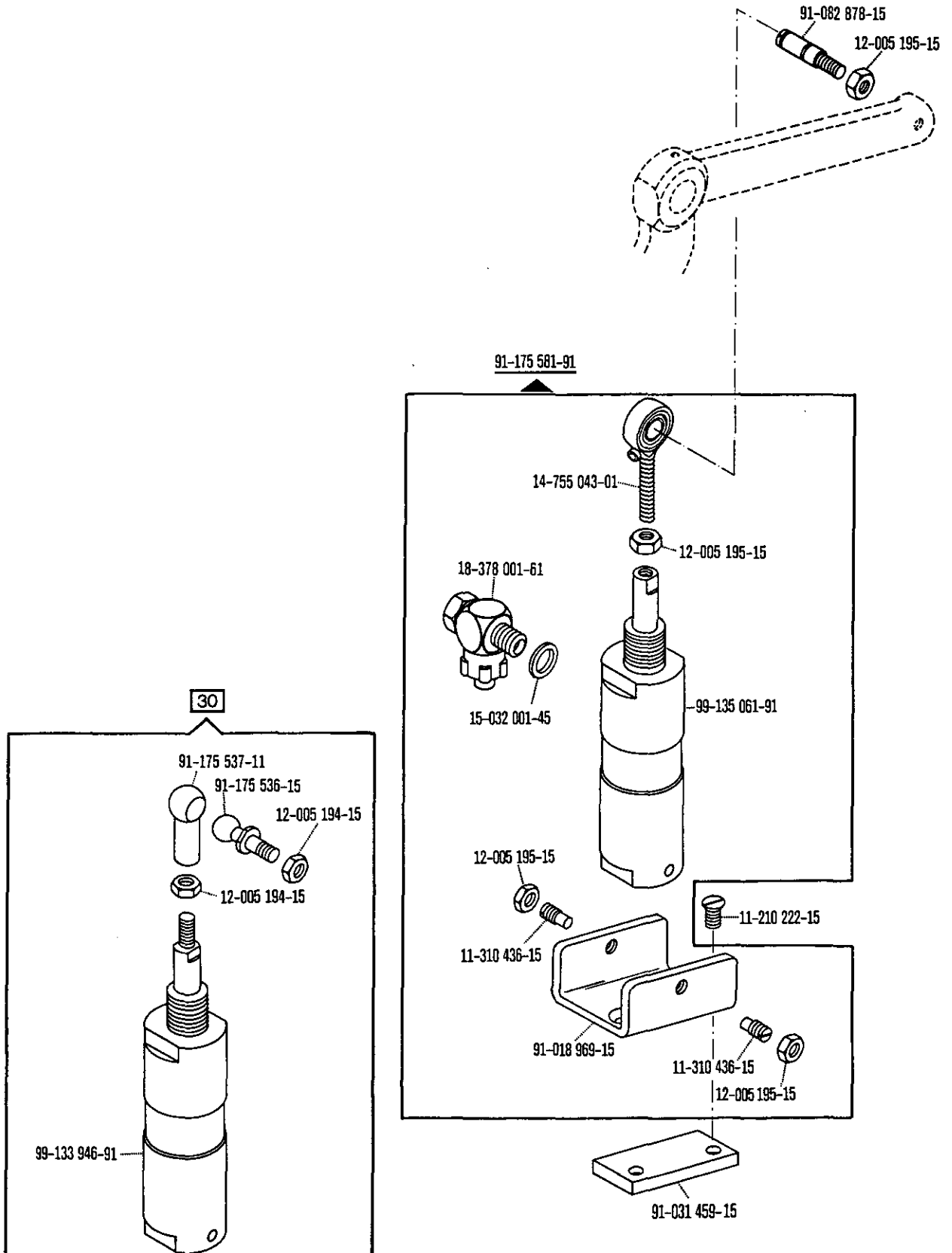

Entfällt bei Pfaff 545 B und 545-900/..
 Omitted on Pfaff 545 B and 545-900/..
 Supprimé sur la Pfaff 545 B et 545-900/..
 Suprimido en la Pfaff 545 B y 545-900/..

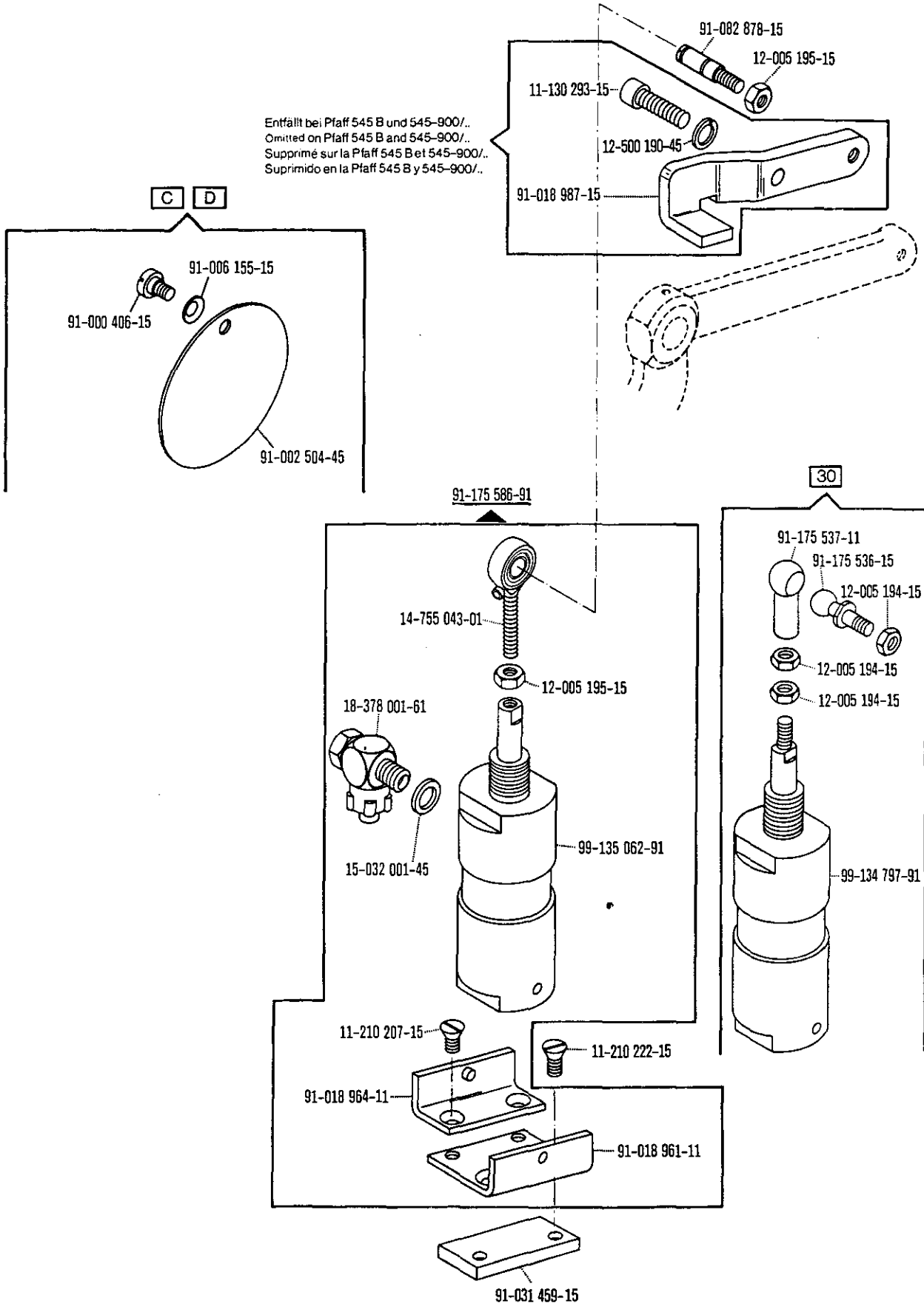

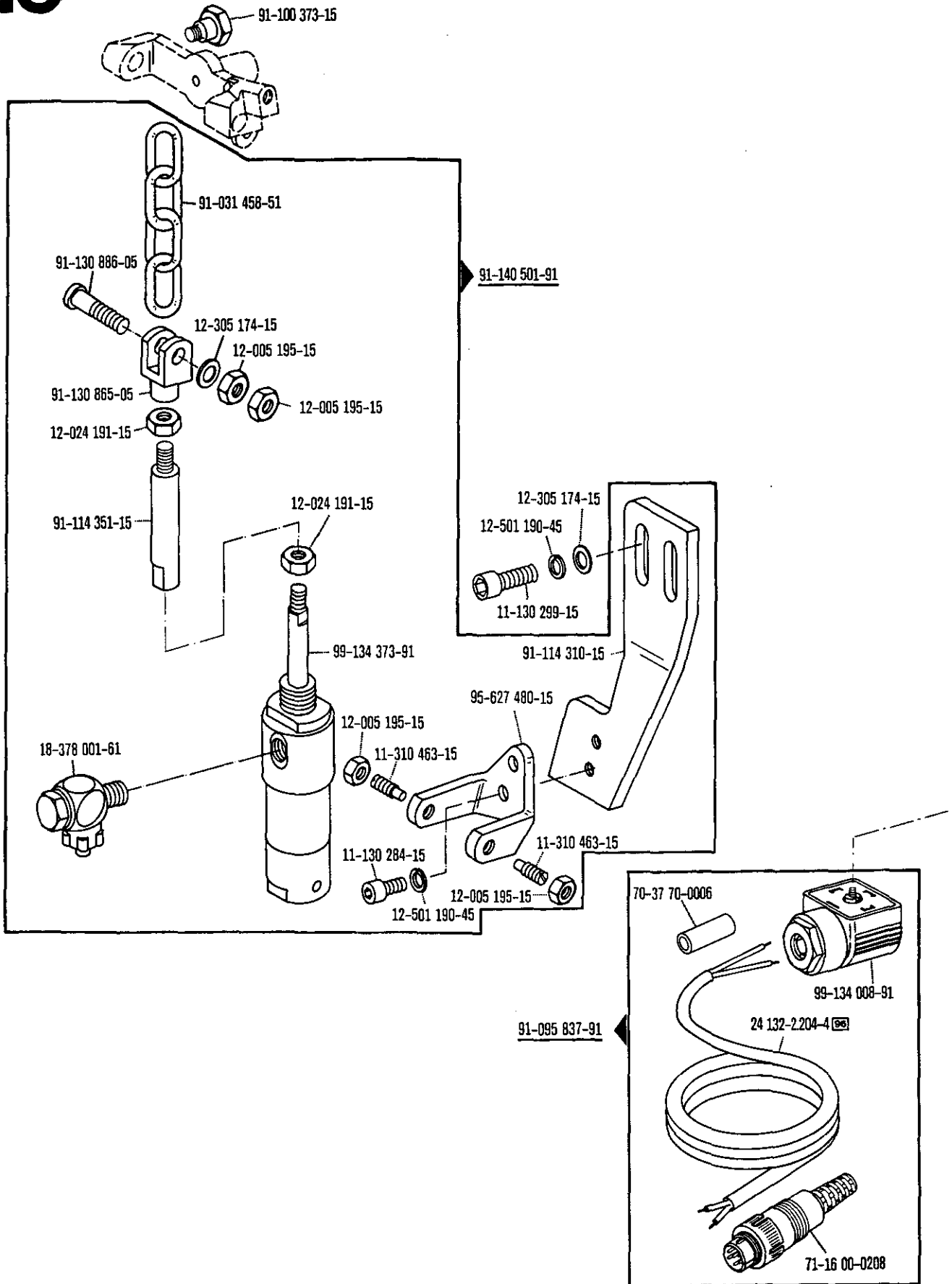

911/35
-911/35
-911/36

zur - pour les
for - para les Pfaff 145; 545

Conditioning unit -925/..requisito
Conditionneur d'air comprimé -925/.. necessaire
Requiere grupo acondicionador del aire comprimido -925/..

11.80

19

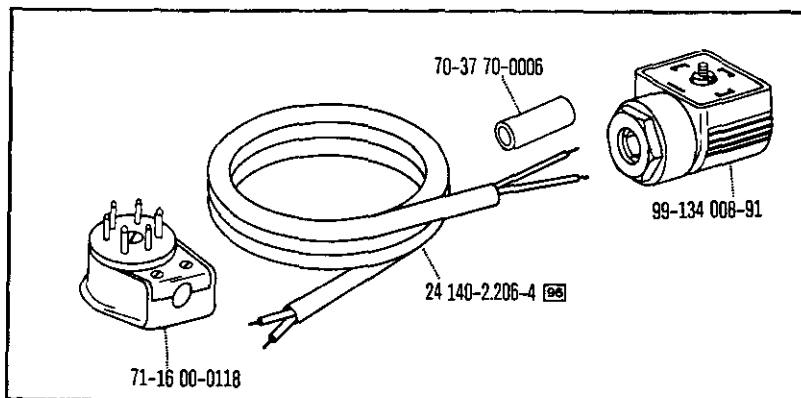
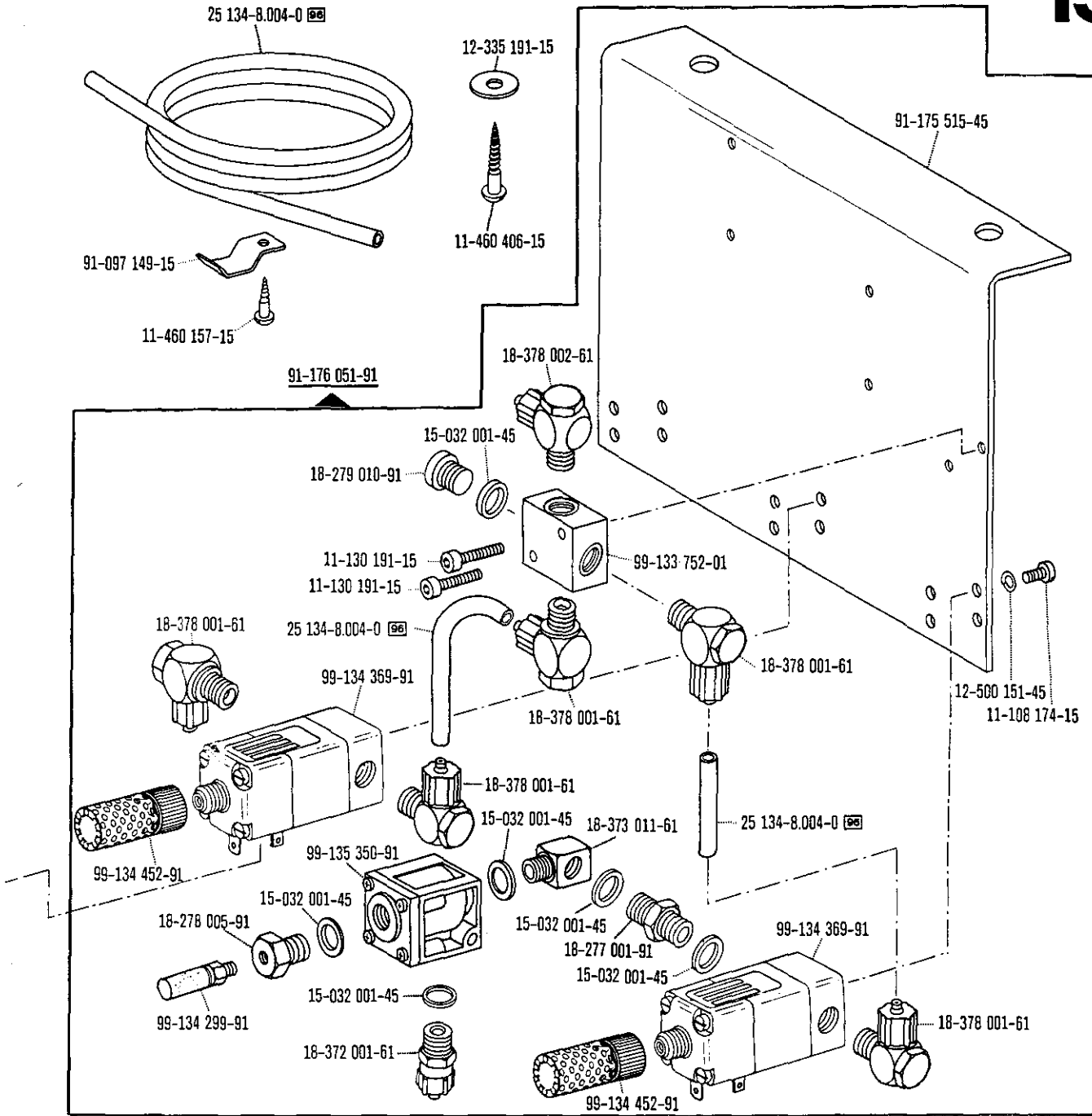

20-000 000-00 00-000 000-00 siehe Erläuterungen Seite 5
see explanations on page 7
voir légende page 9

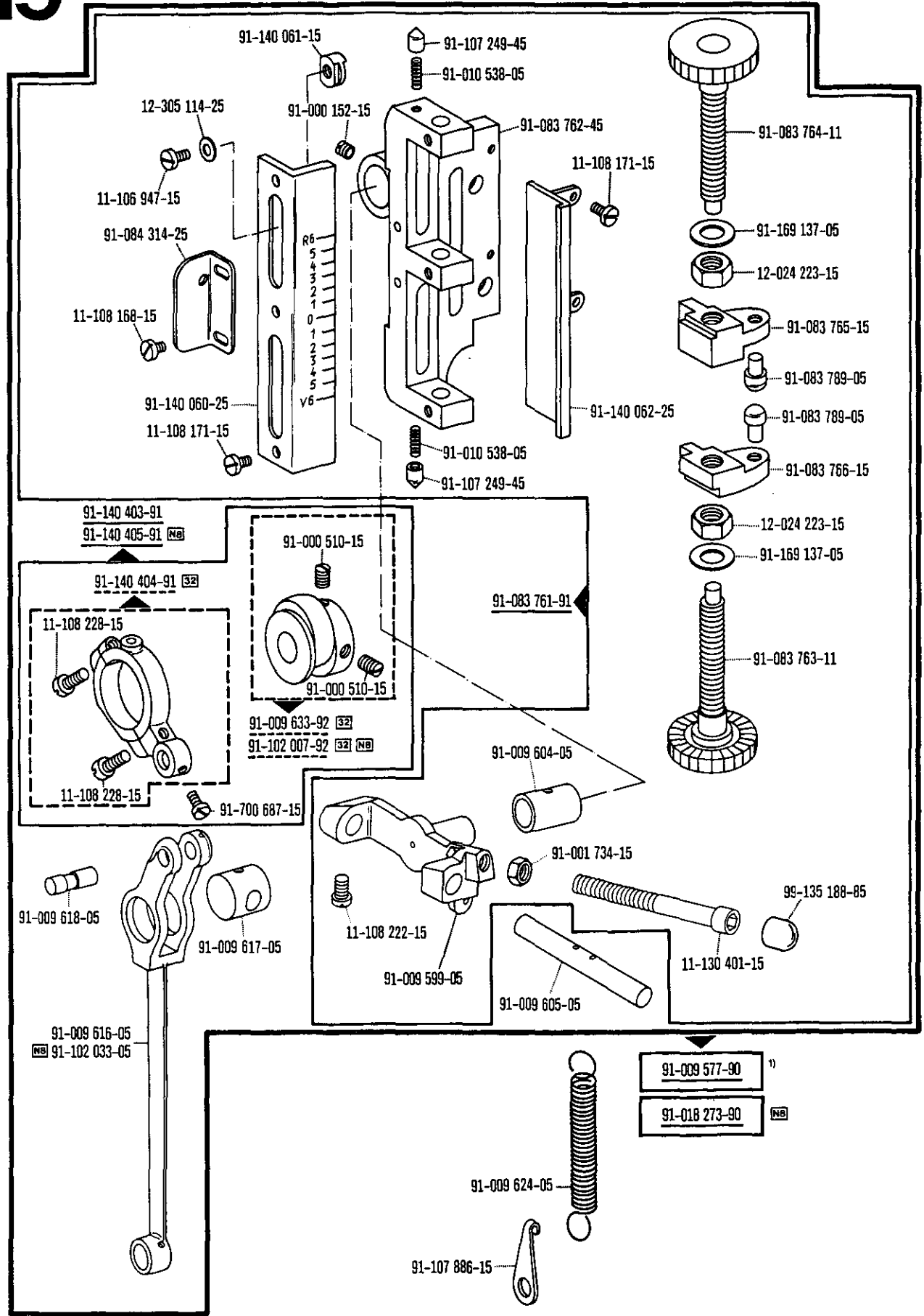

91-091 585-91 90/11

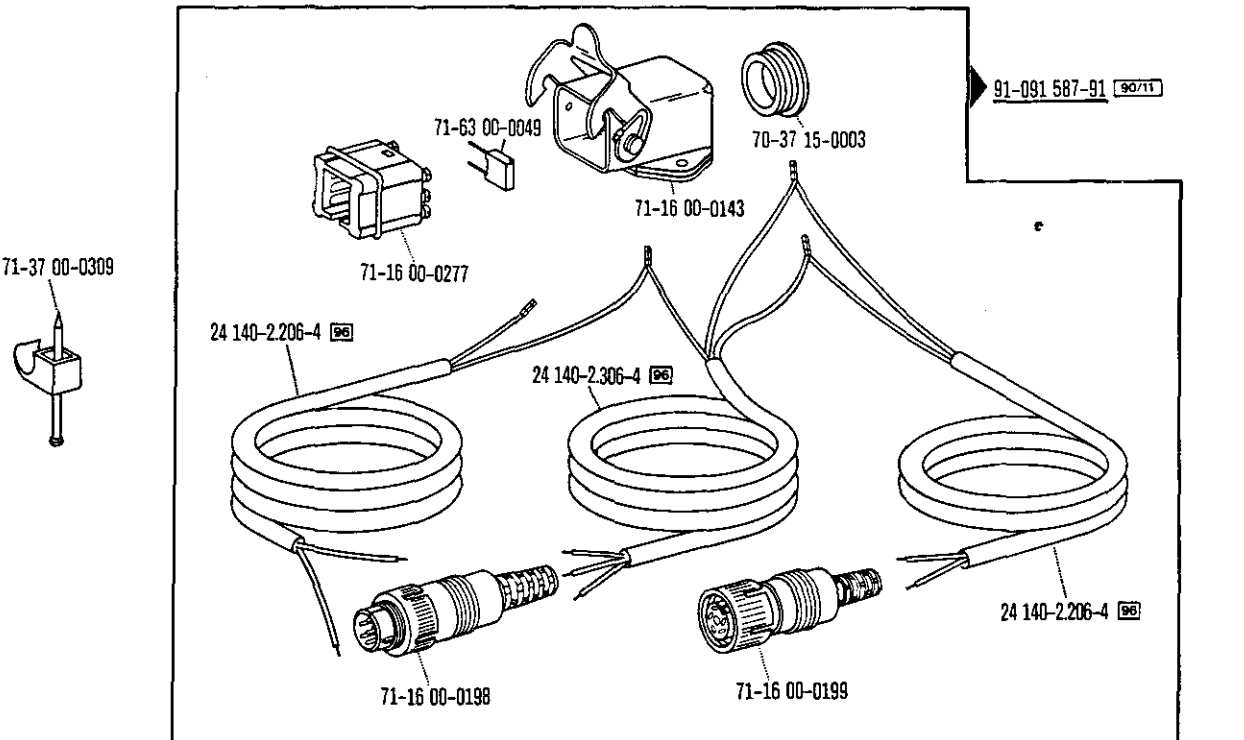
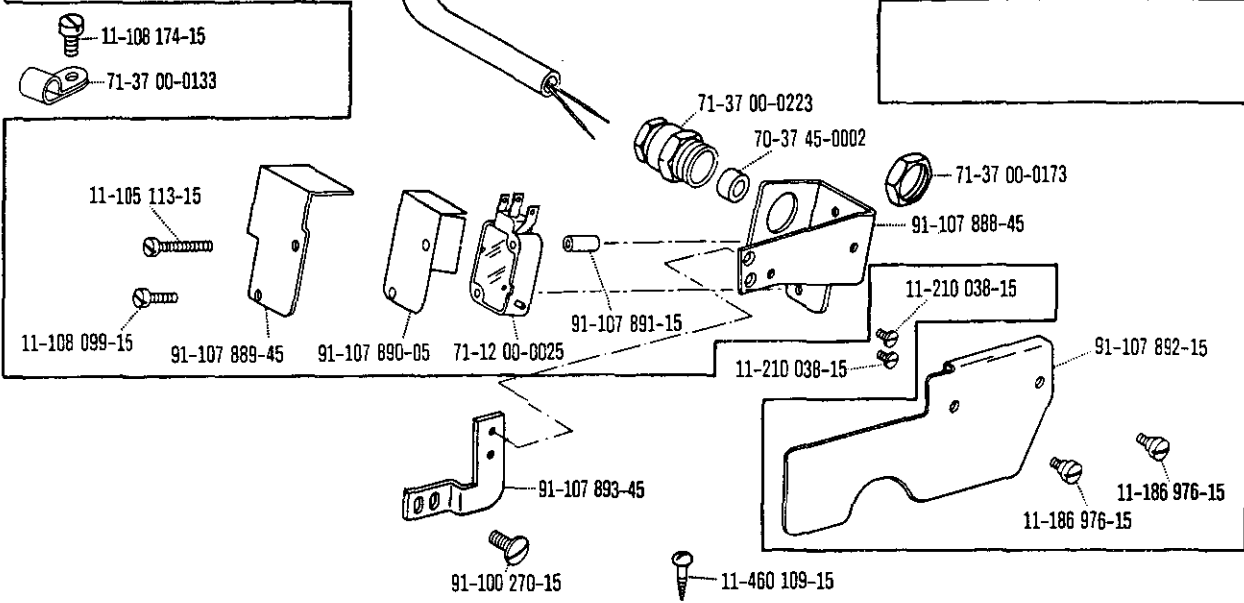
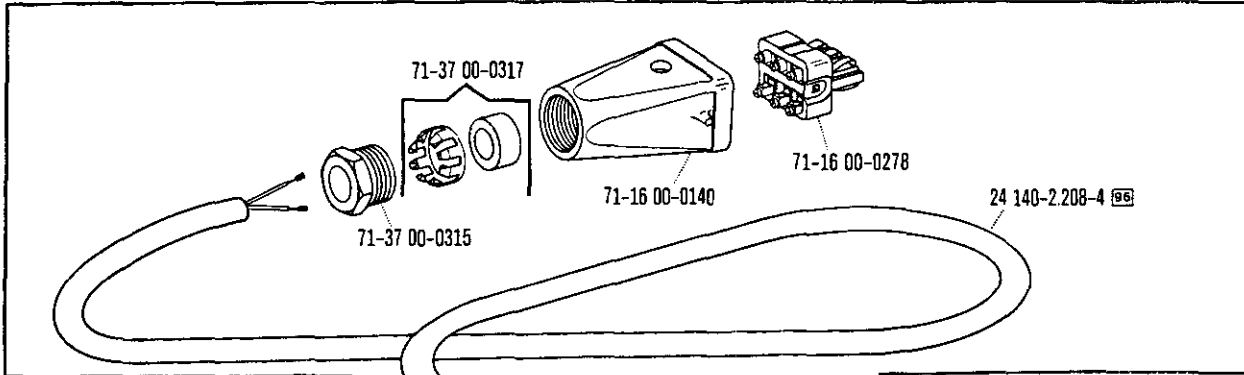

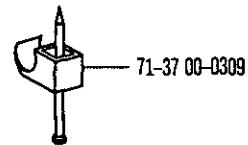
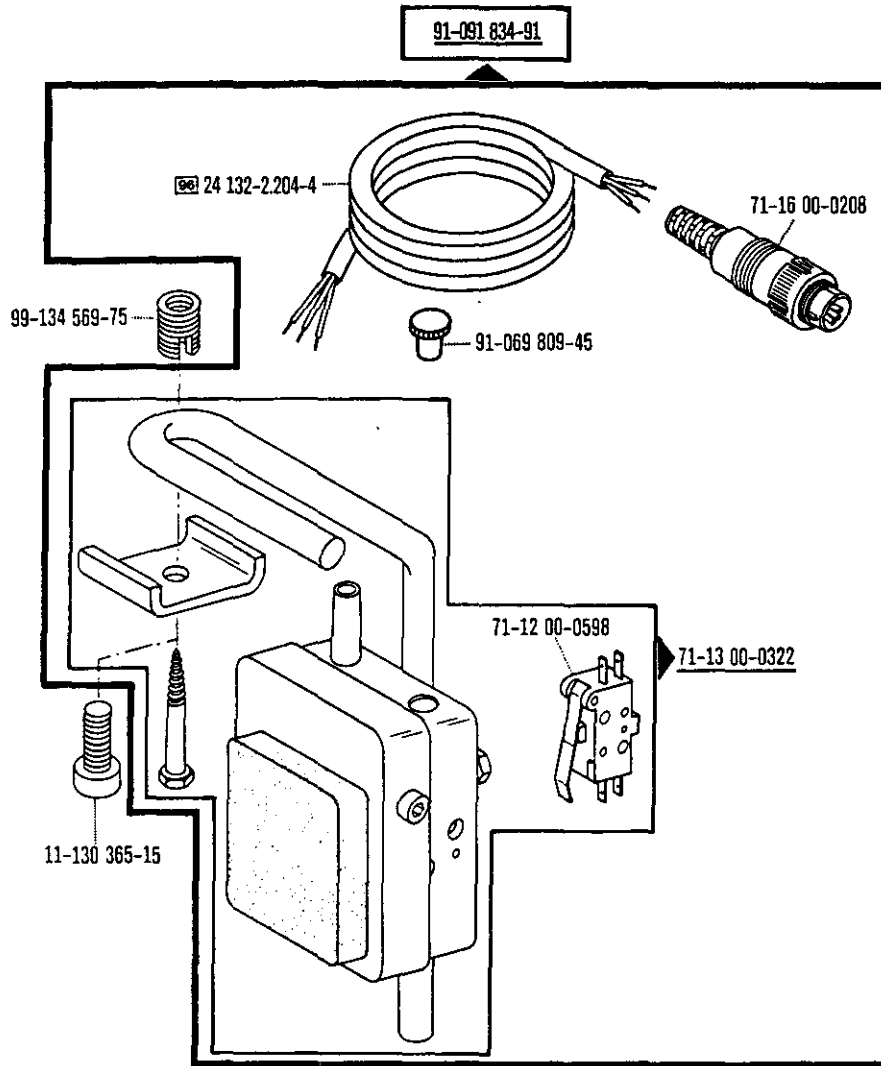

91-171 462-90

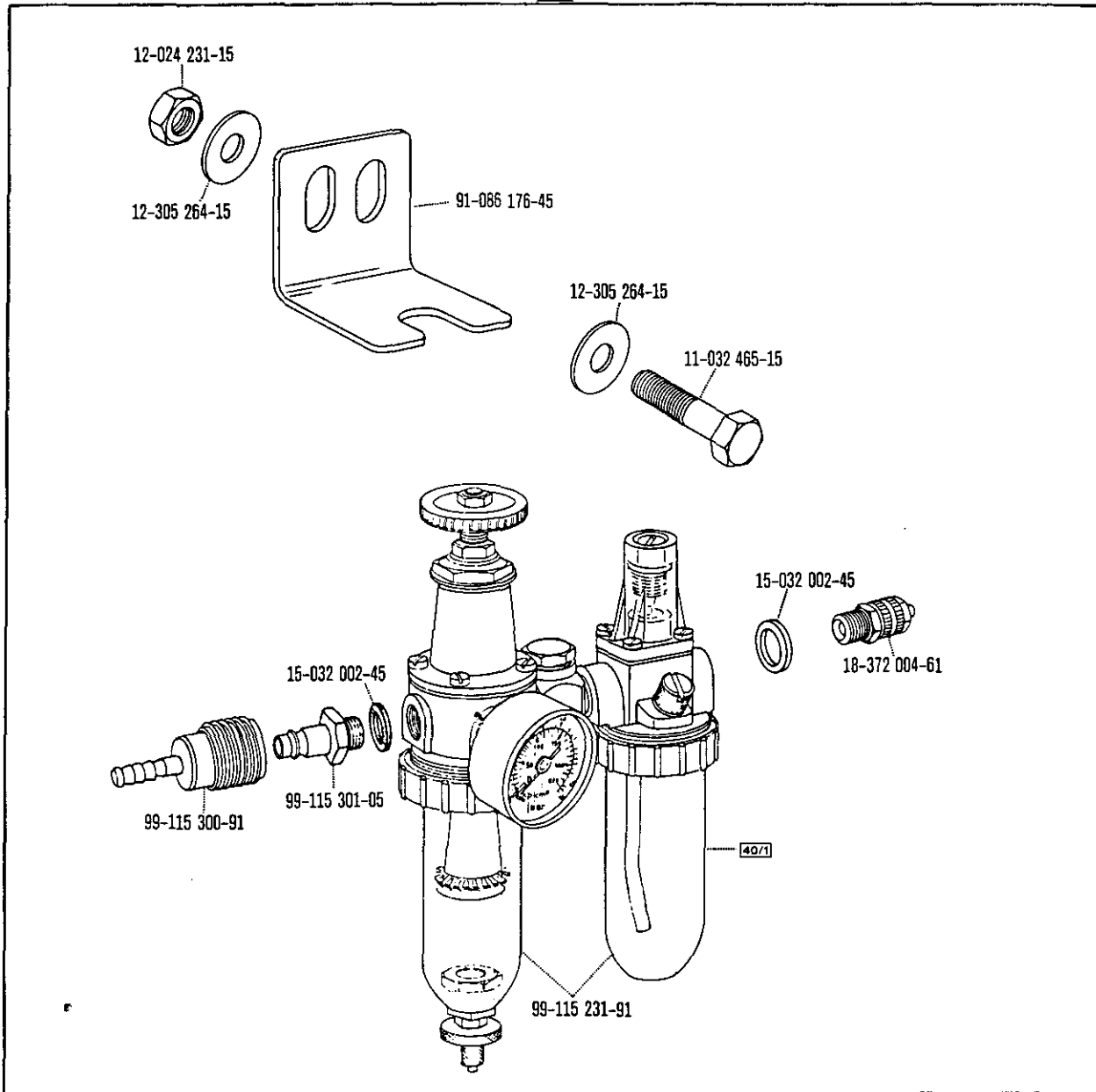

25 134-8.005-0 99

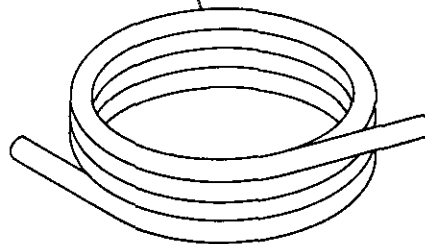

91-082 231-90

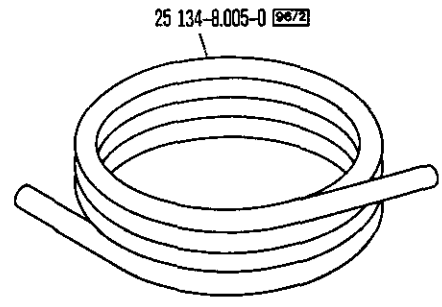
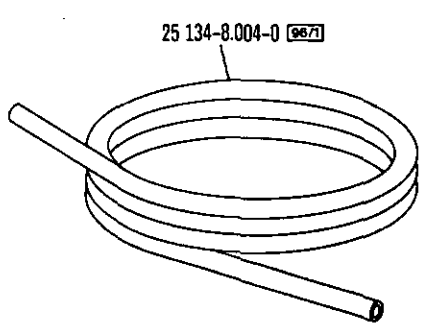
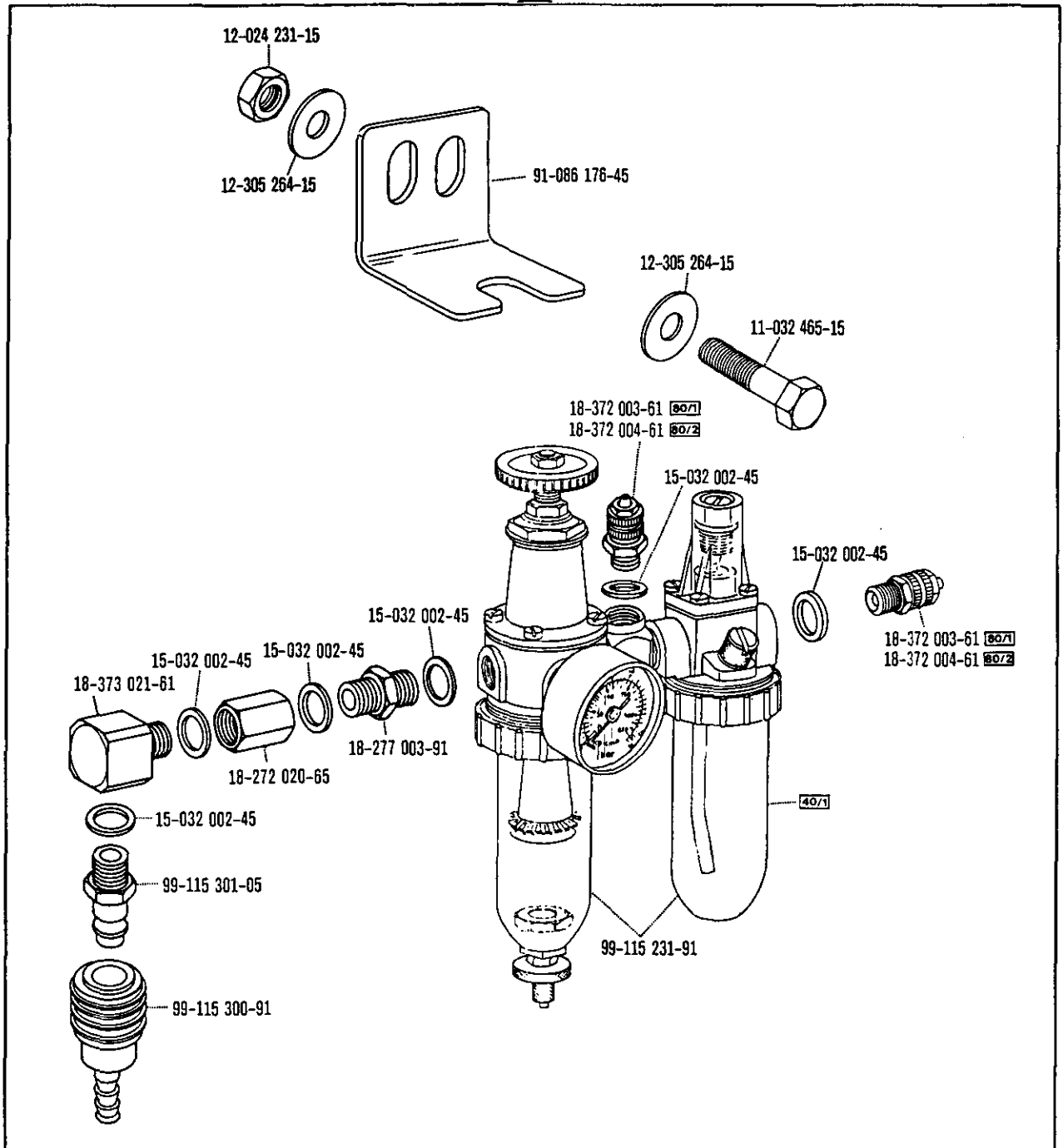

91-033 073-90

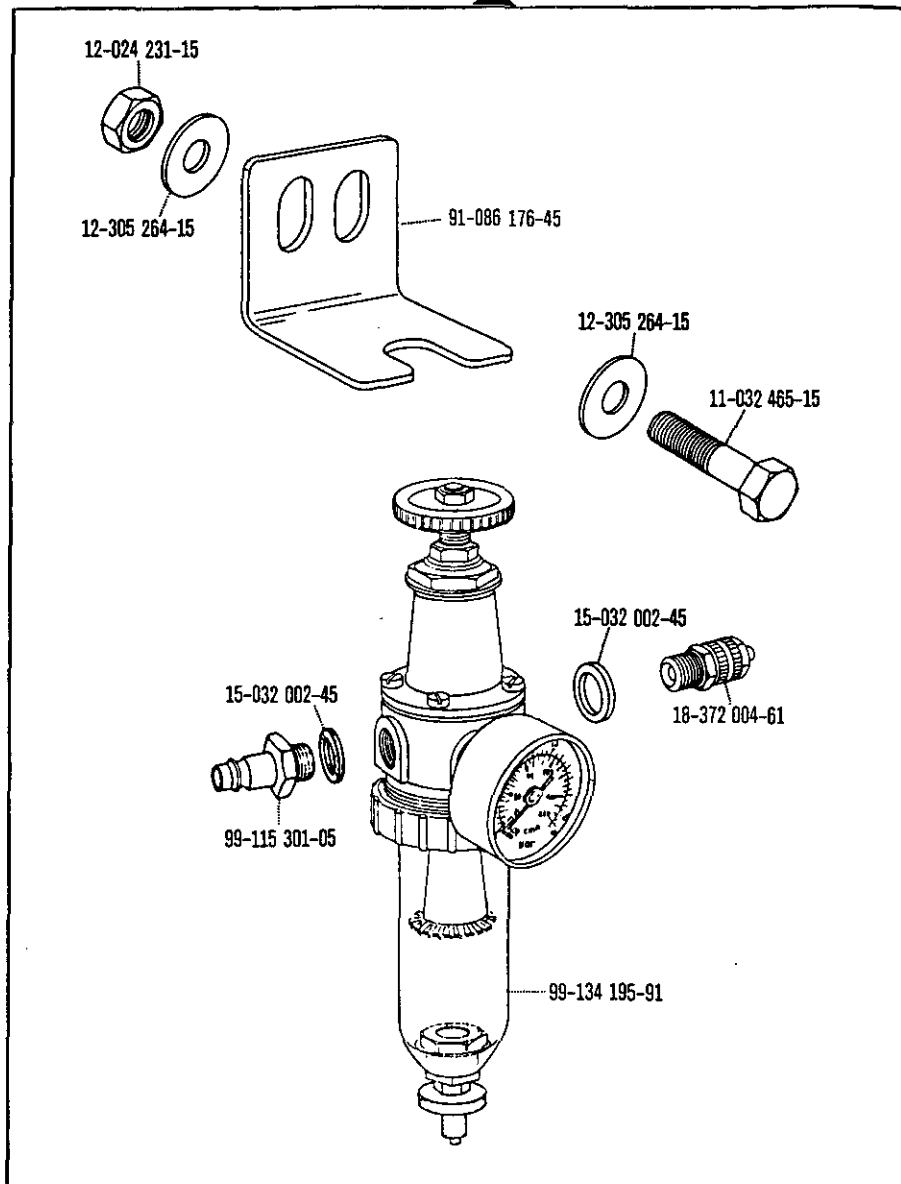

25 134-8.005-0

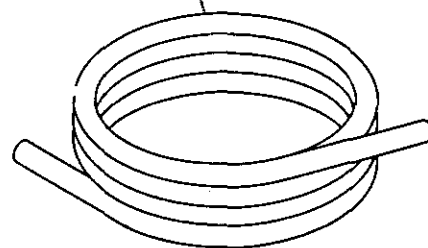

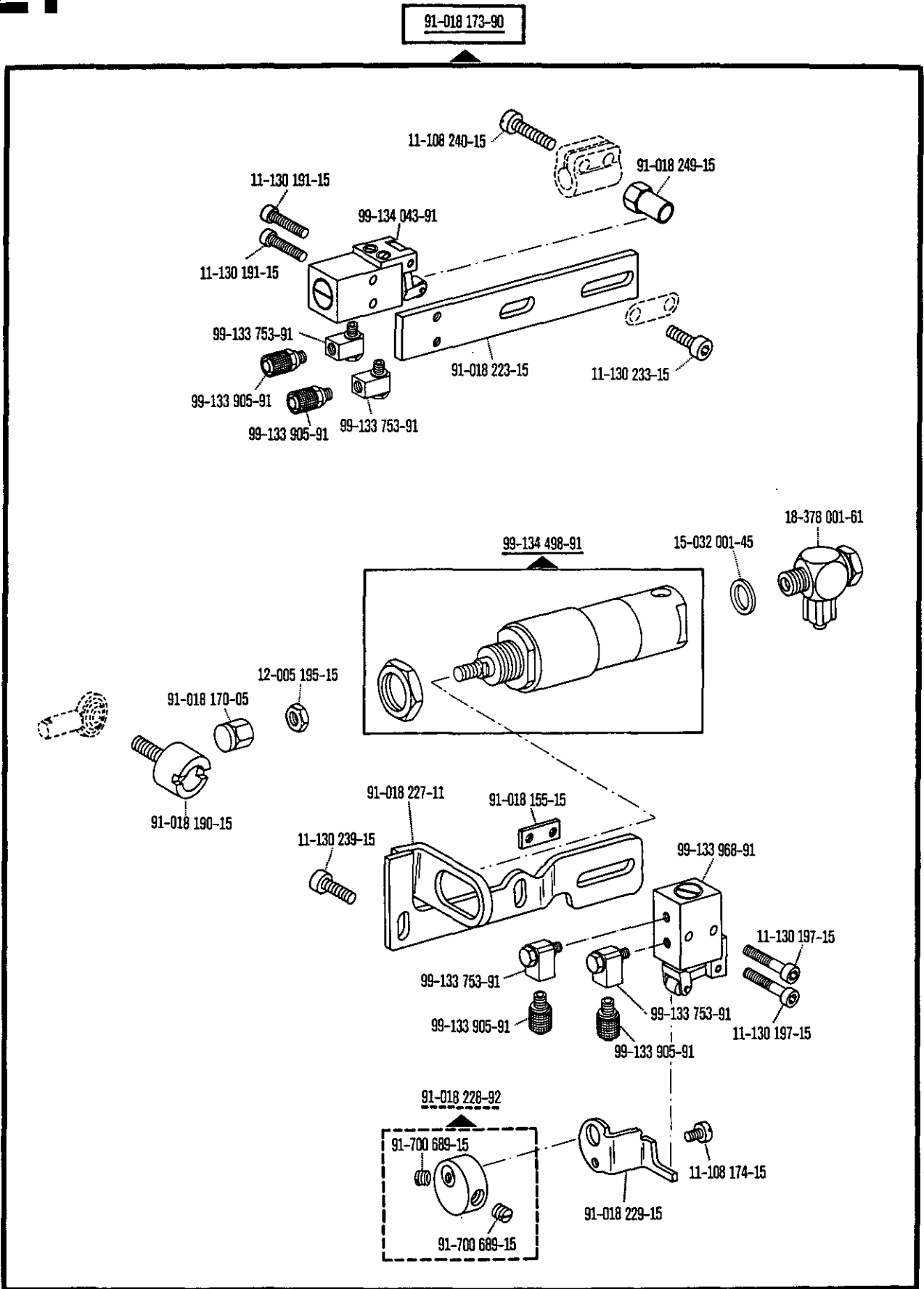

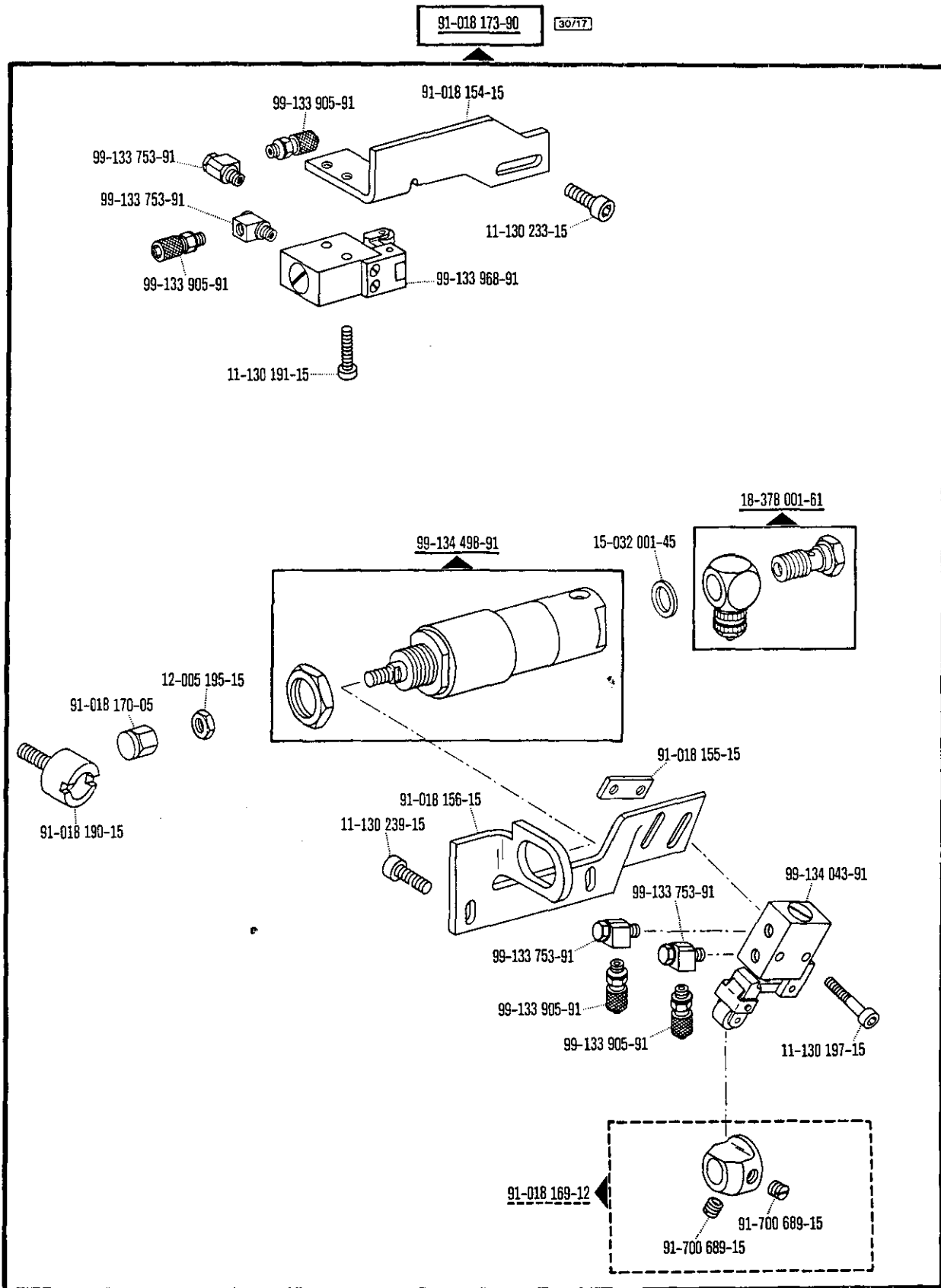

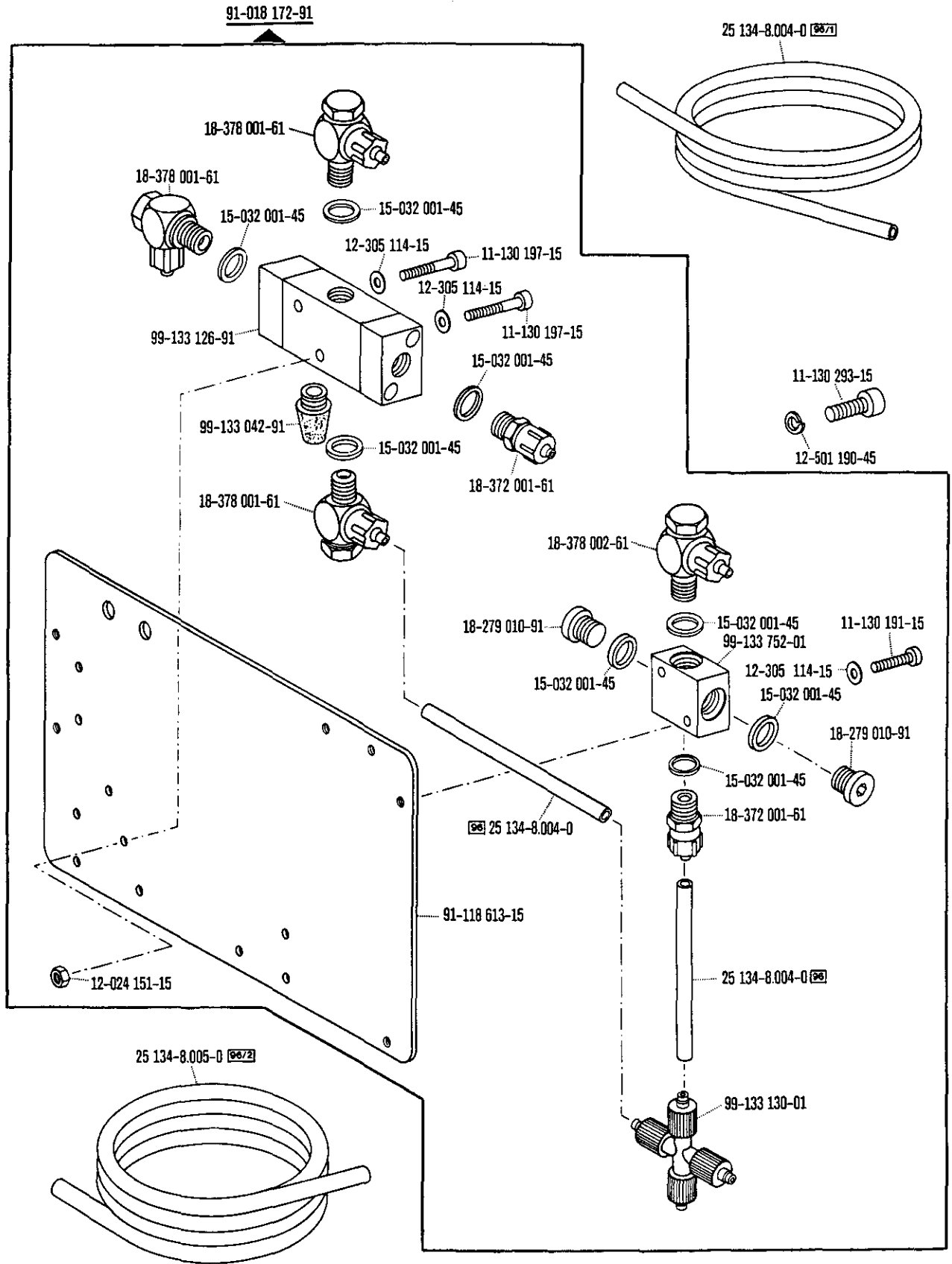

91-056 183-91

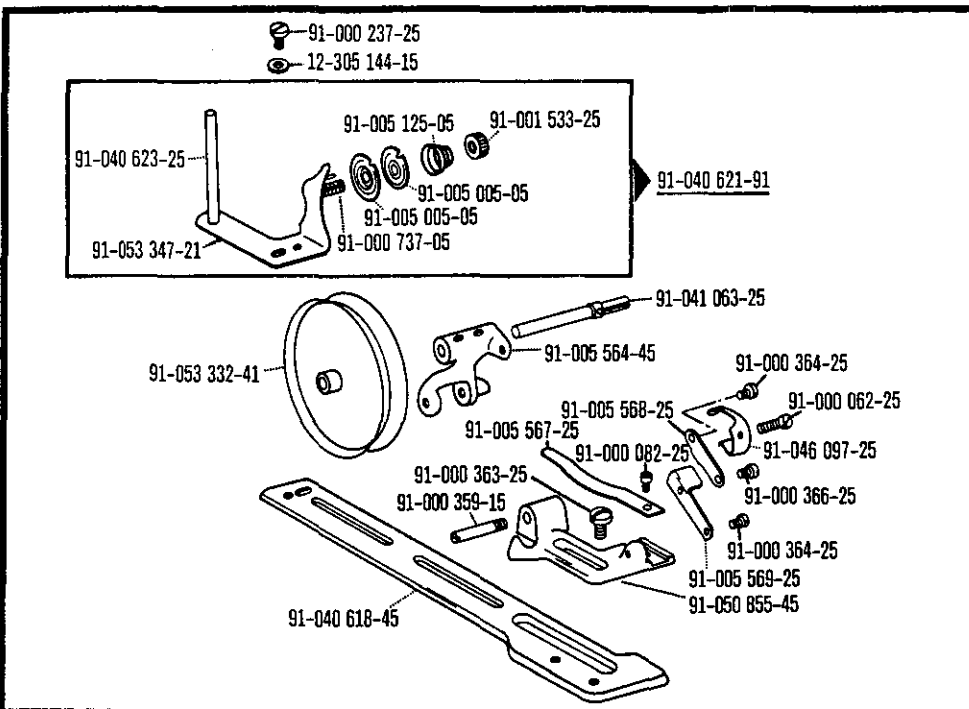
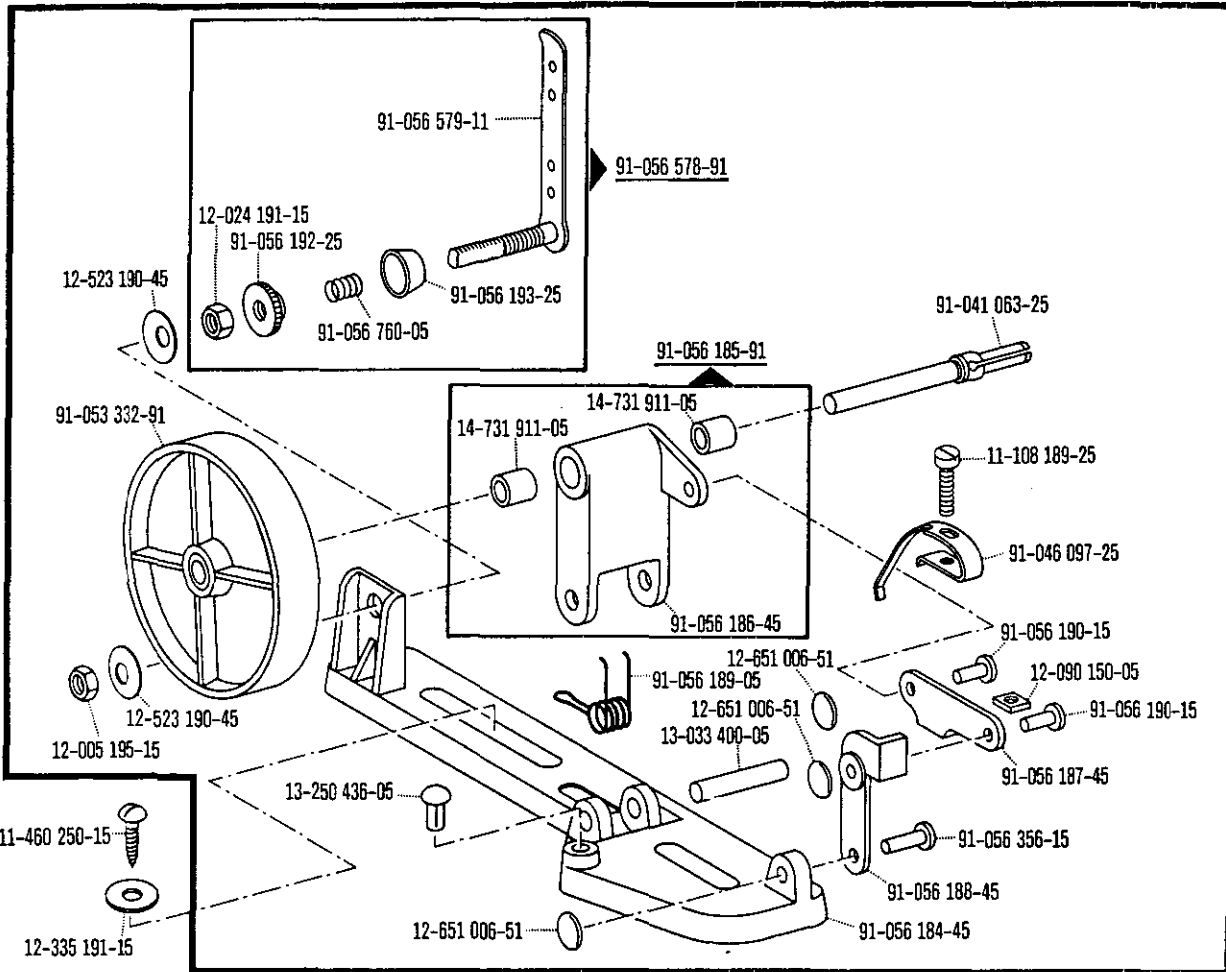

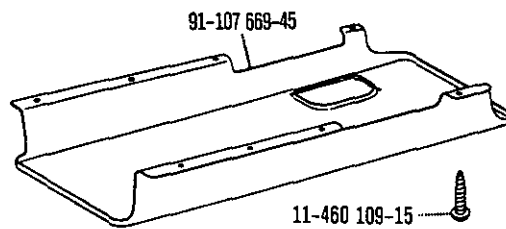
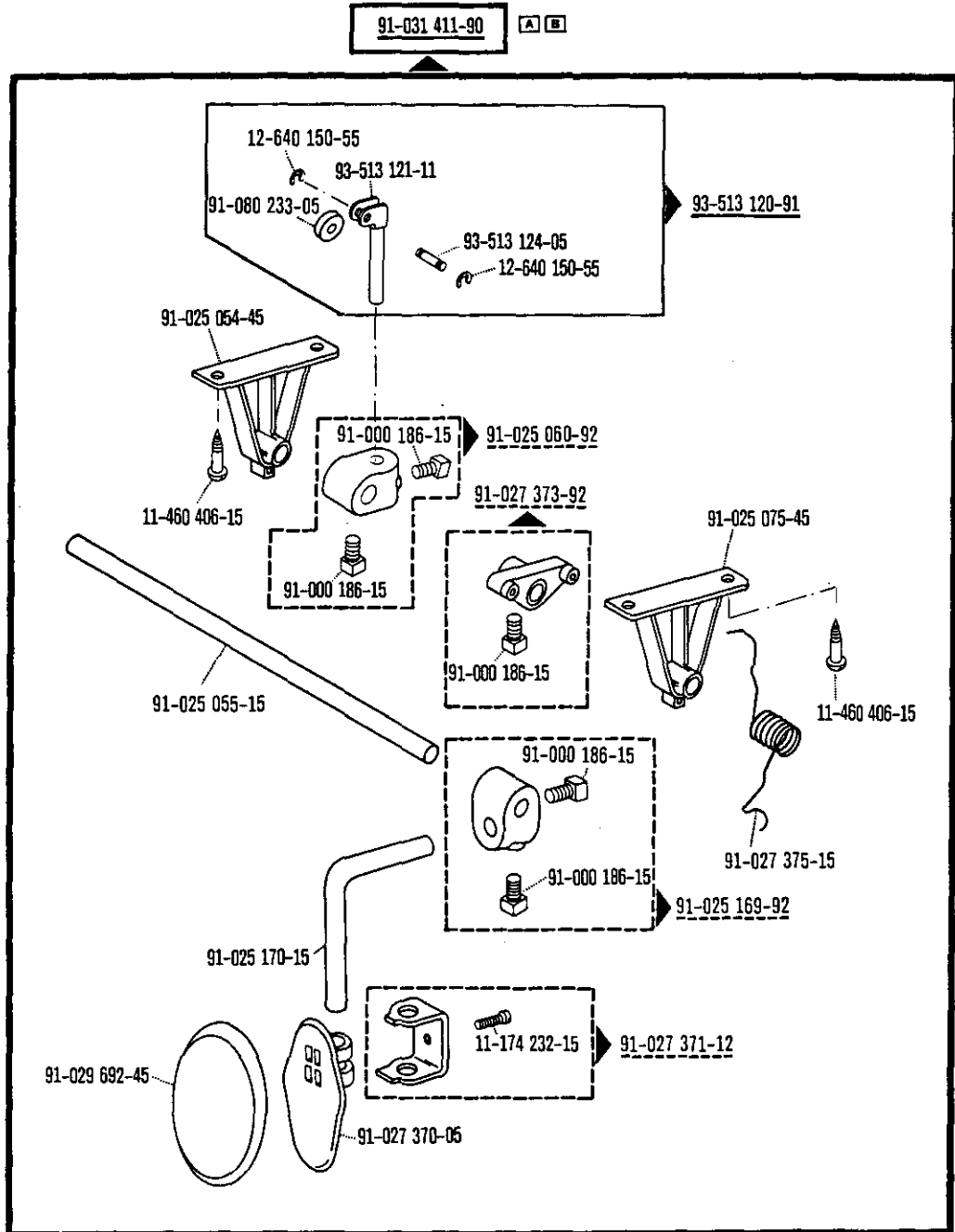

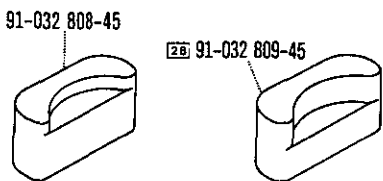
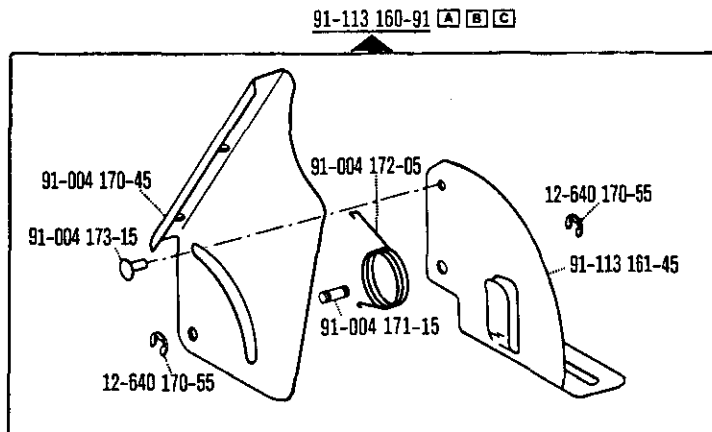
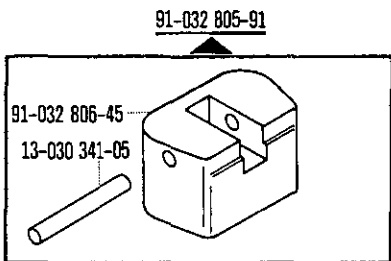
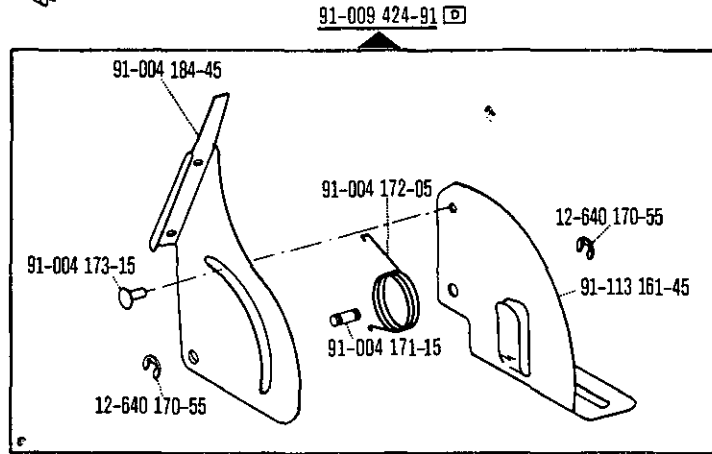
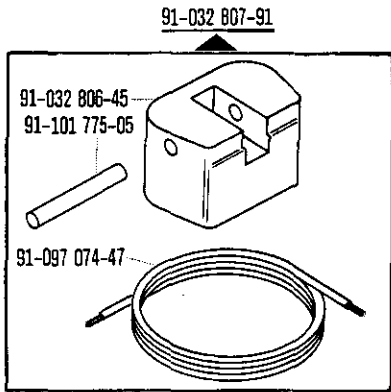
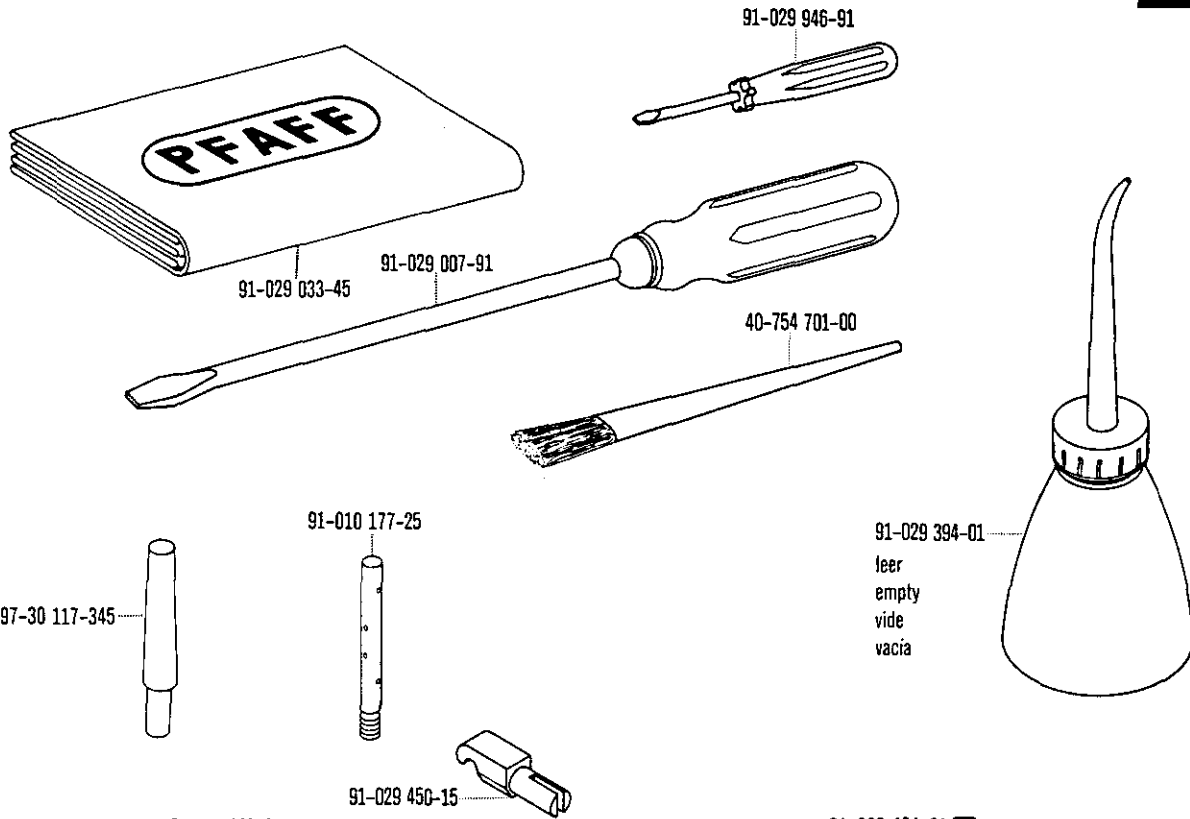

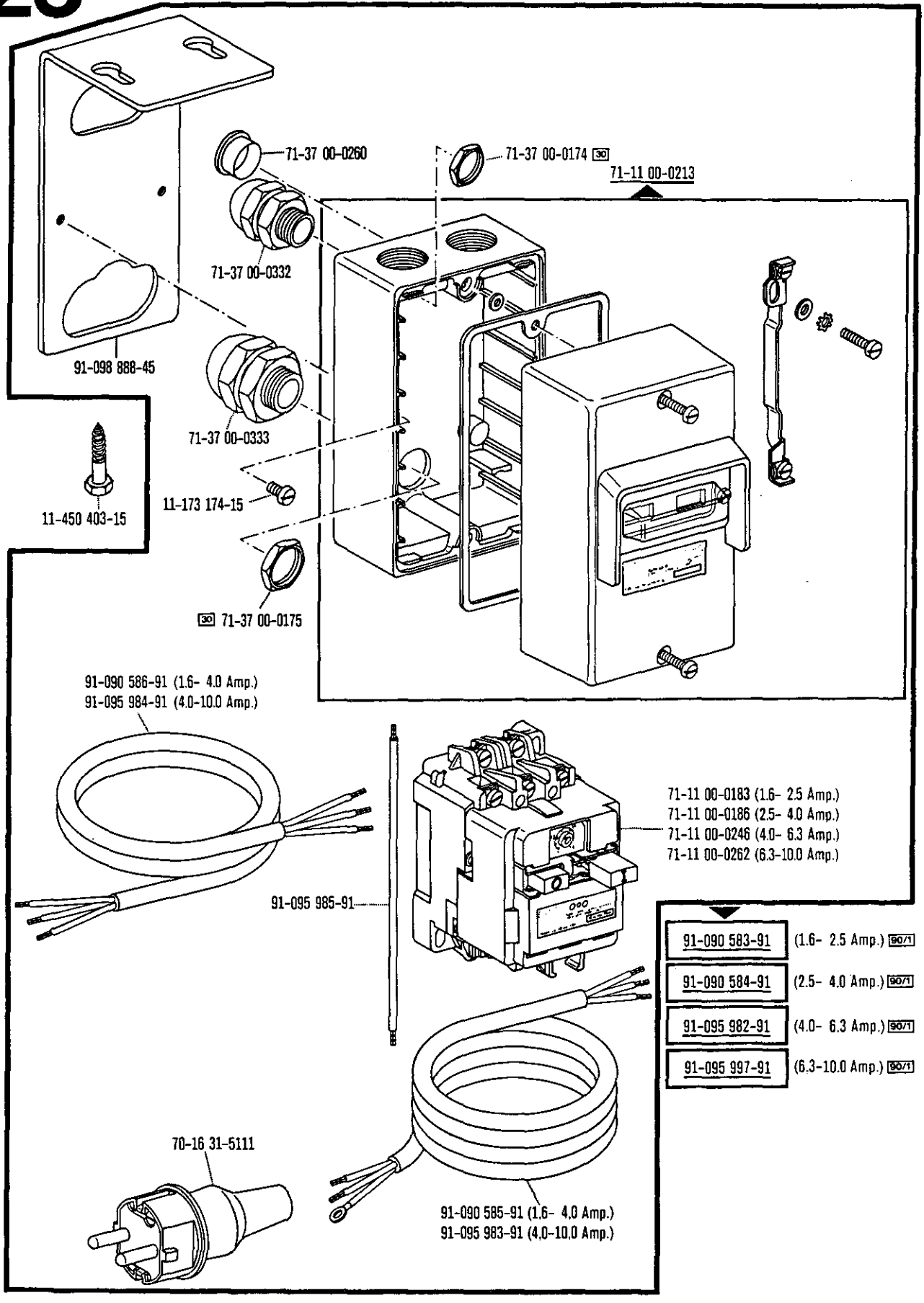

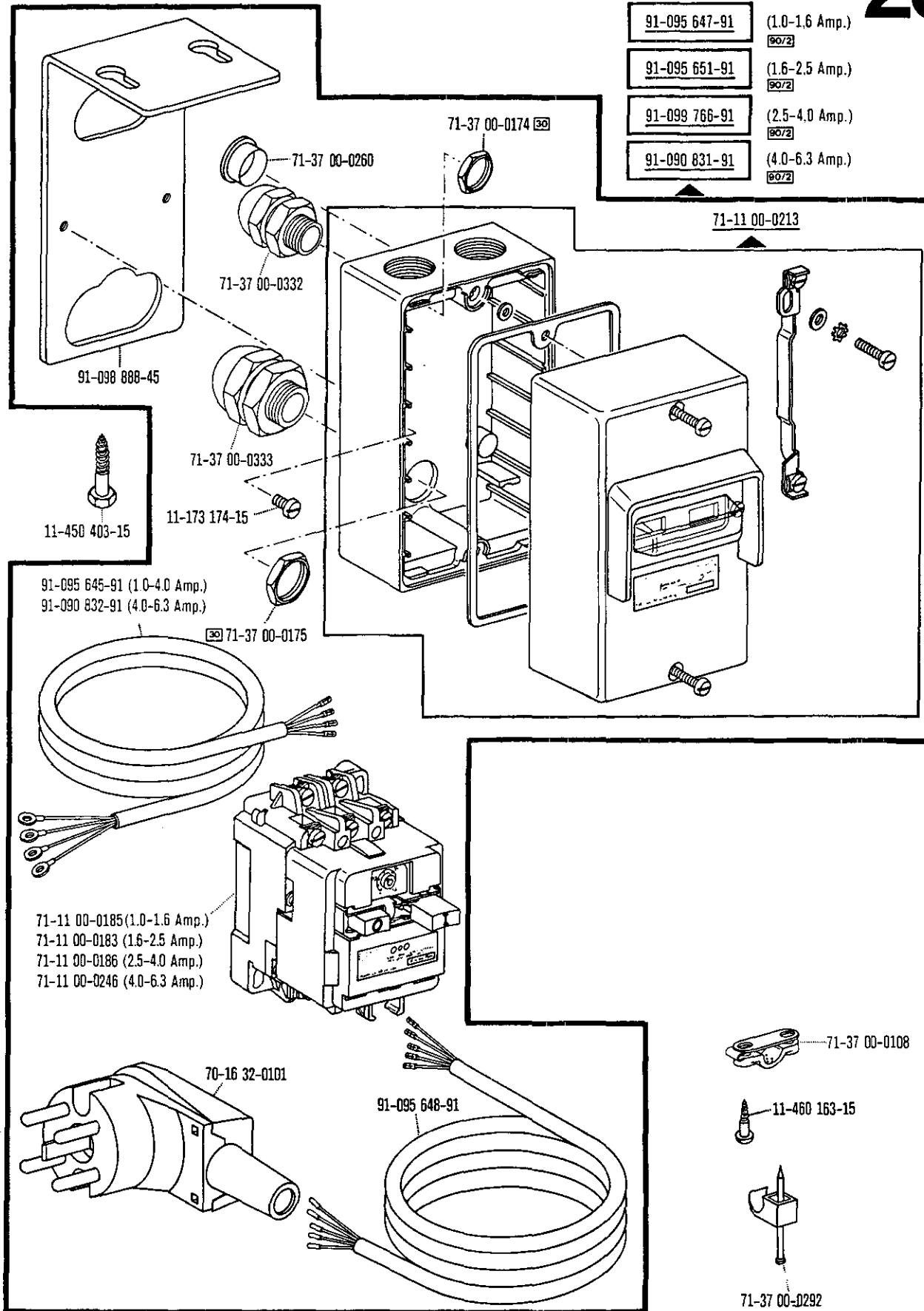

00-000 000-00 00-000 000-00 00-000 000-00 30 90/2

siehe Erläuterungen Seite 5
 see explanations on page 7
 voir légende page 9
 ver explicaciones de la página 11

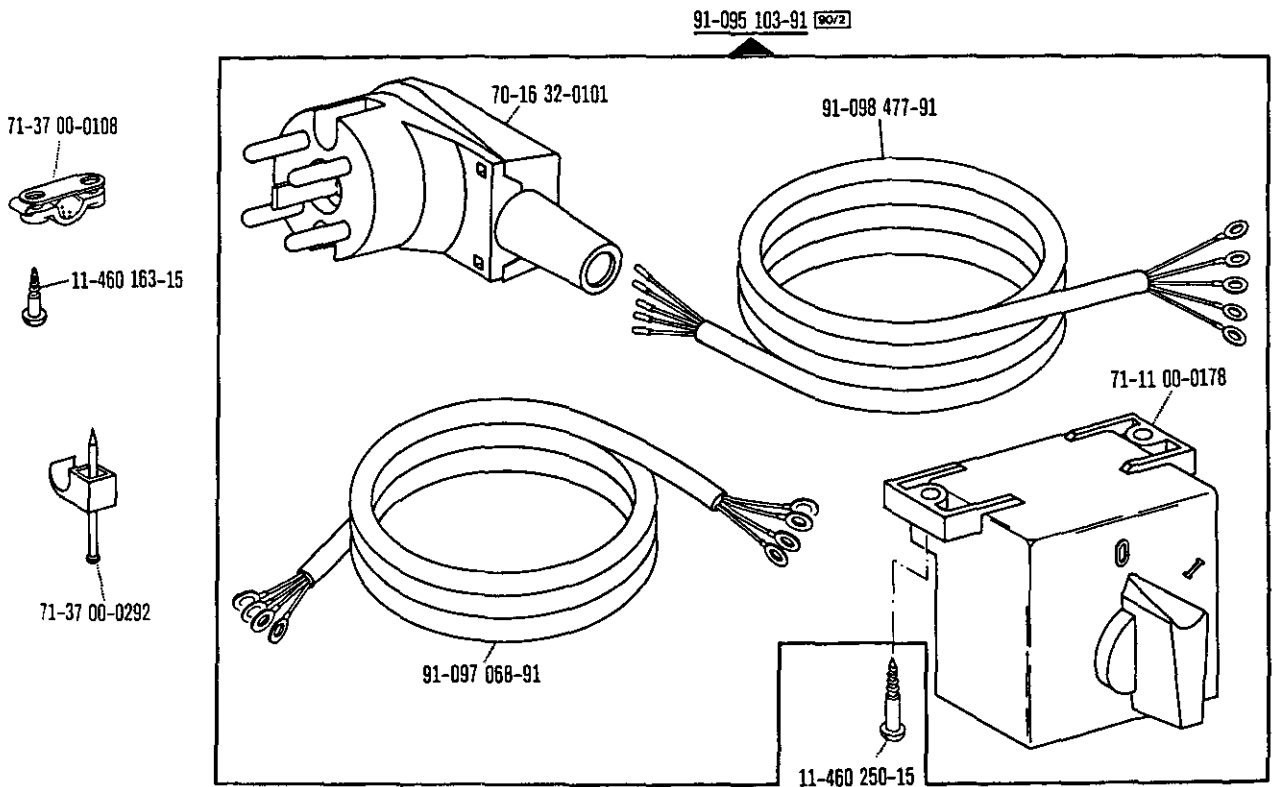
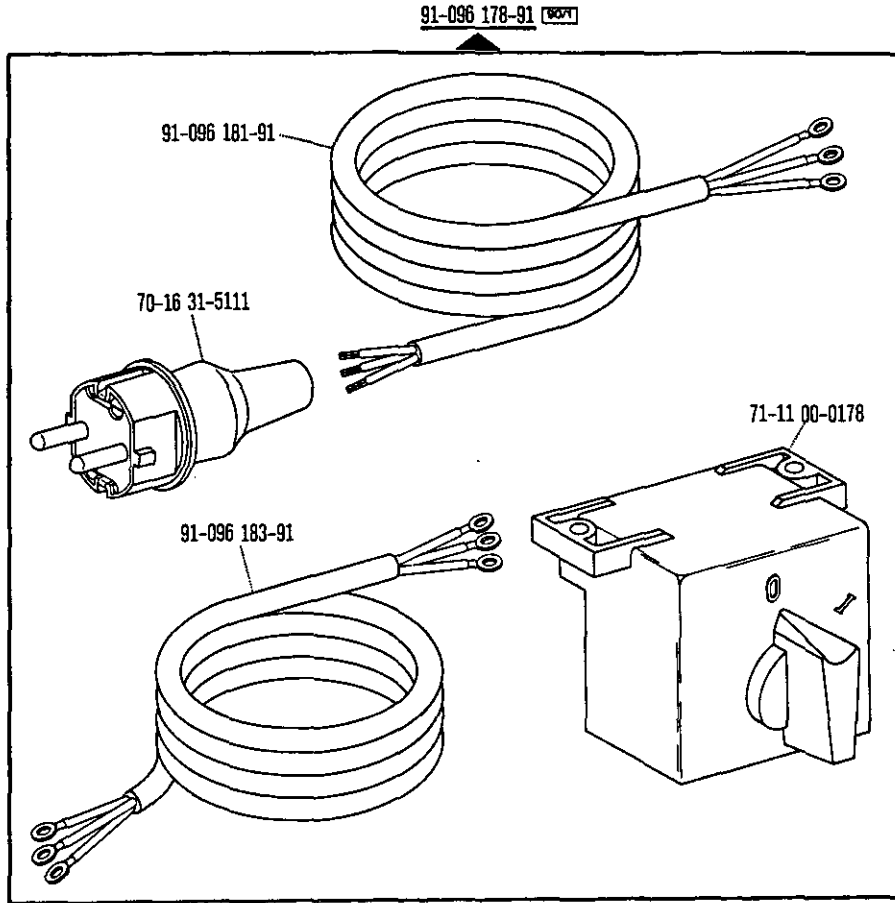

Levier de commande à tirette du moteur
 Palanca de mando por tracción para el motor

11.80

24

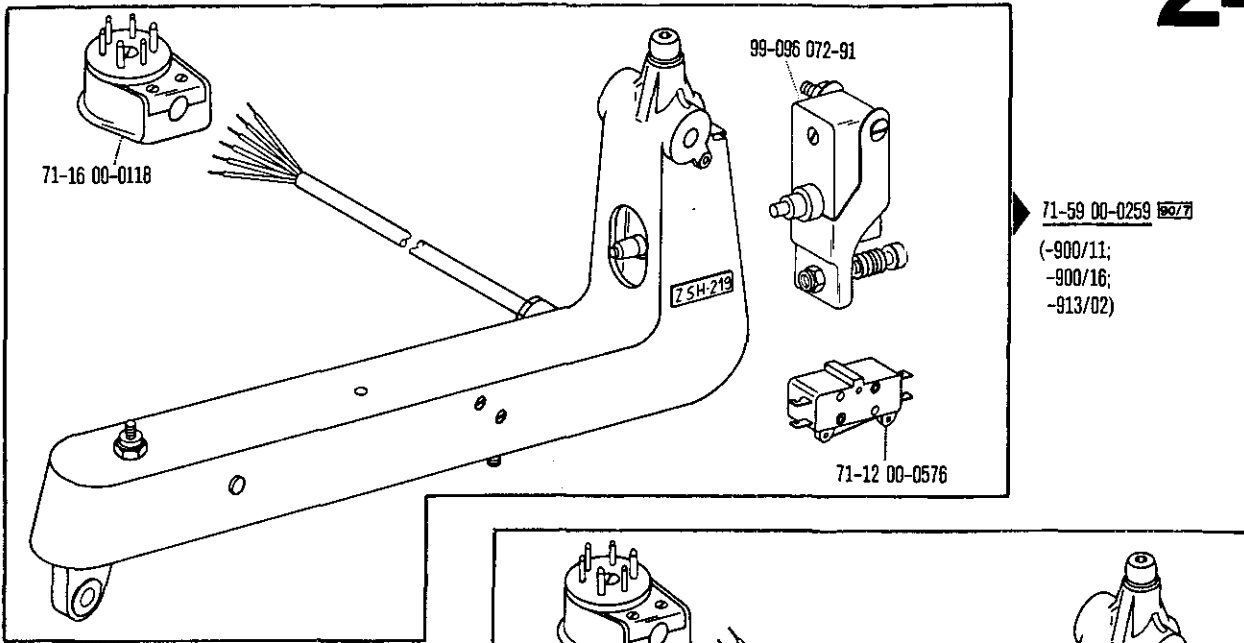

71-59 00-0268
 (-900/11;
 -913/02)

71-59 00-0237 (-900/..-910/..)

(nur bei Quick-Hebel-Stop-Motor NDK 700)
 (on lever-operated NDK 700 Quick-Stop motor only)
 (uniquement pour moteur Quick-Stop à levier, NDK 700)
 (sólo en motores Quick-Stop de palanca NDK 700)

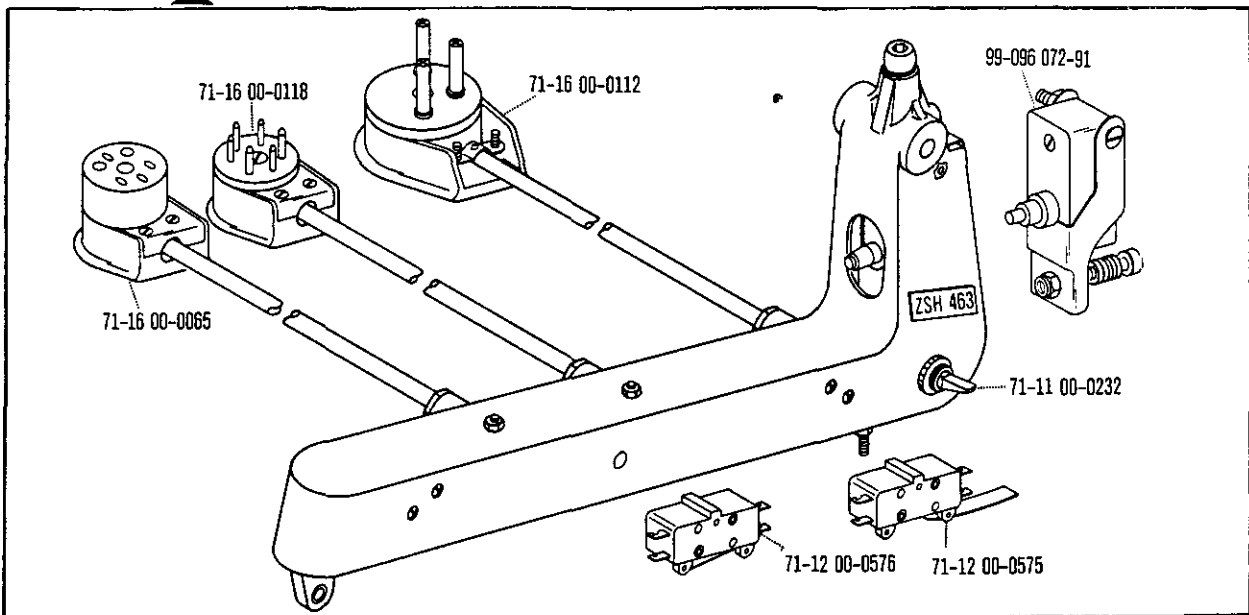
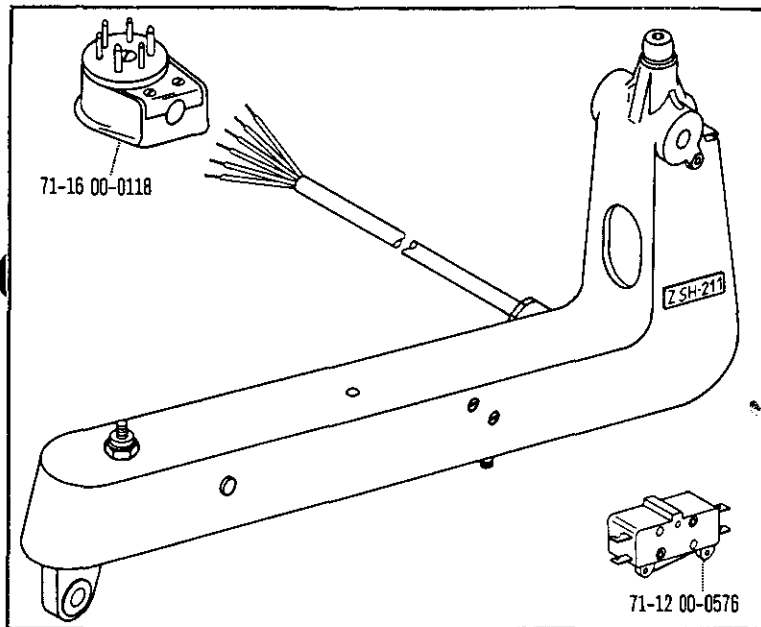

71-14 00-0006 (-913/02)

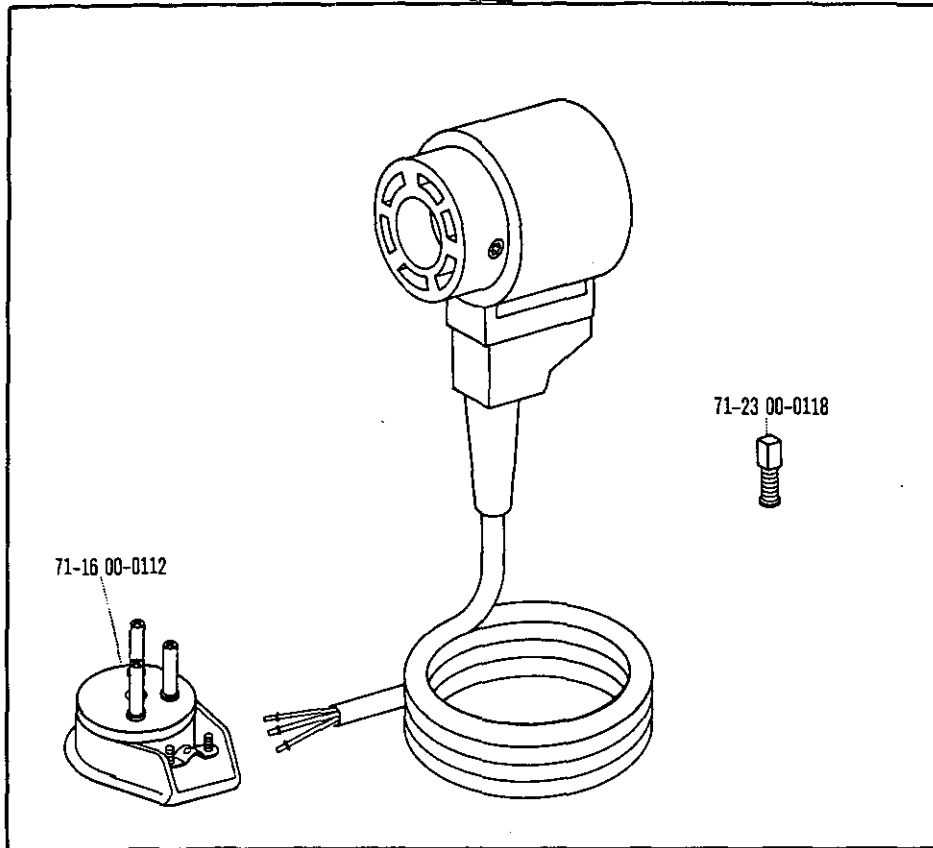

91-018 983-11 (90/15)

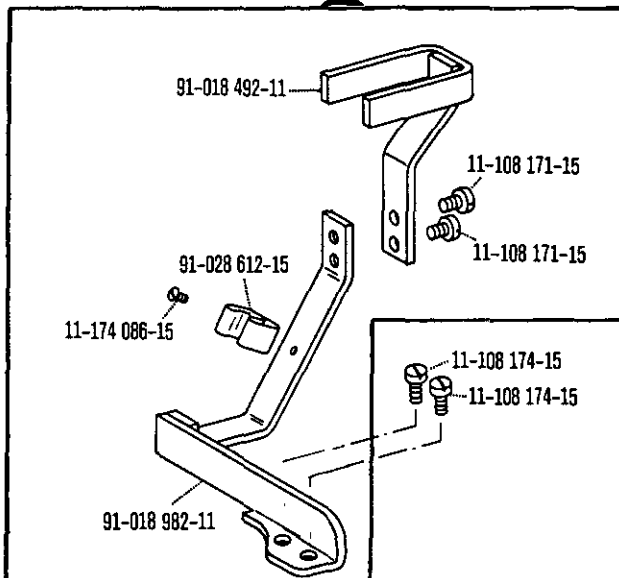

91-018 489-11 (90/16)

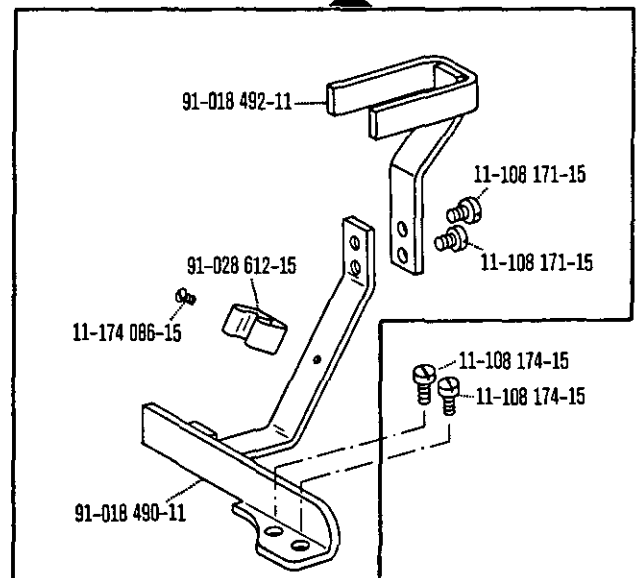

71-14 00-0003 (-900/06)

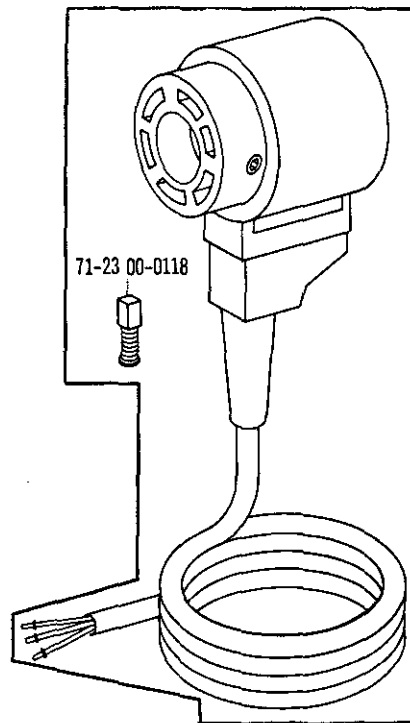
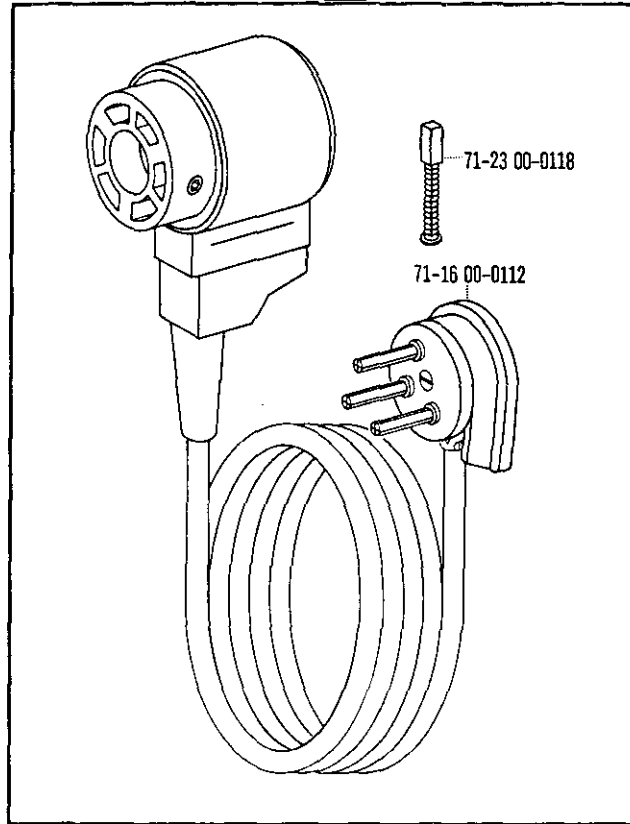

91-095 856-91 (-900/11; -900/16)

-900/51
-900/56
-913/52

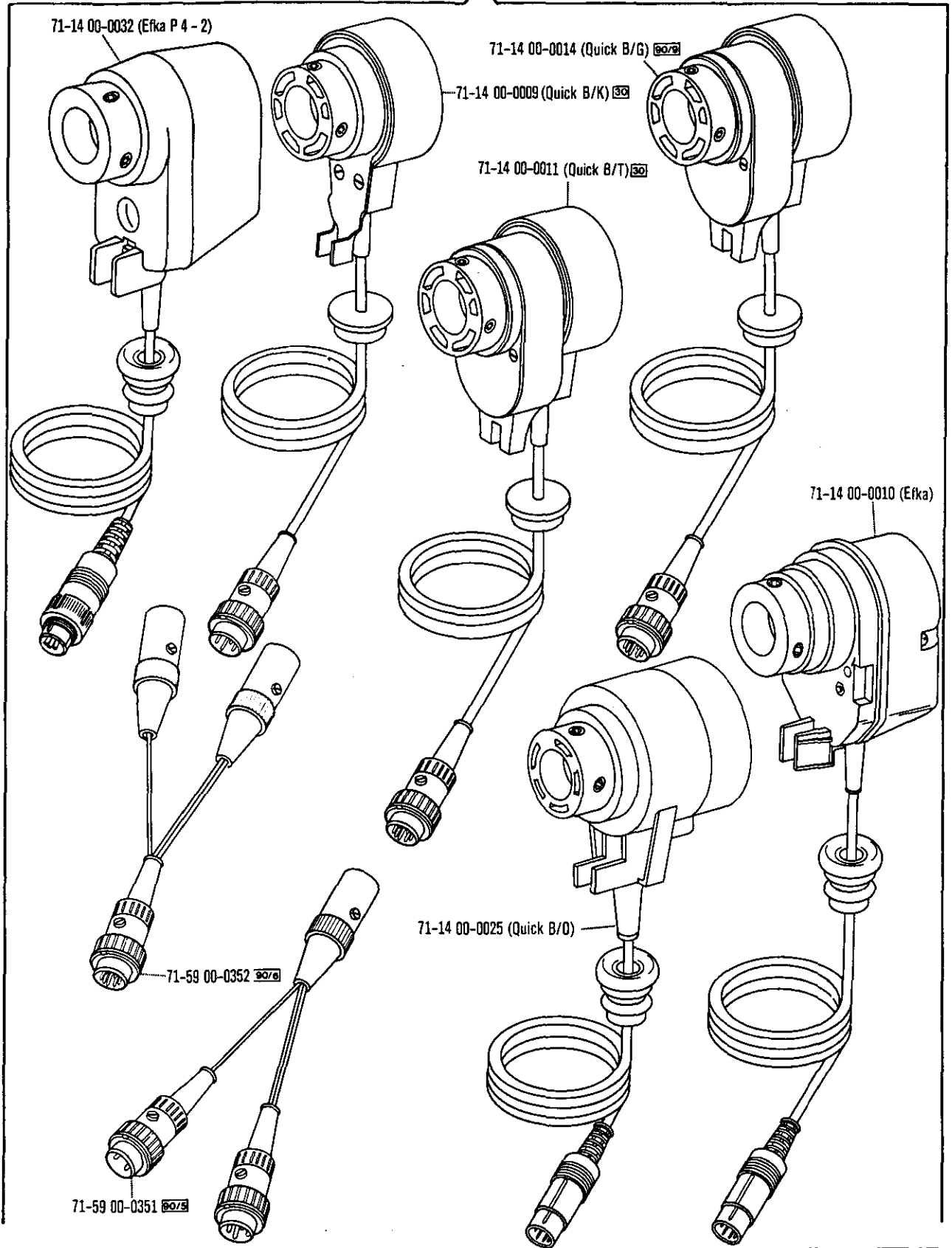

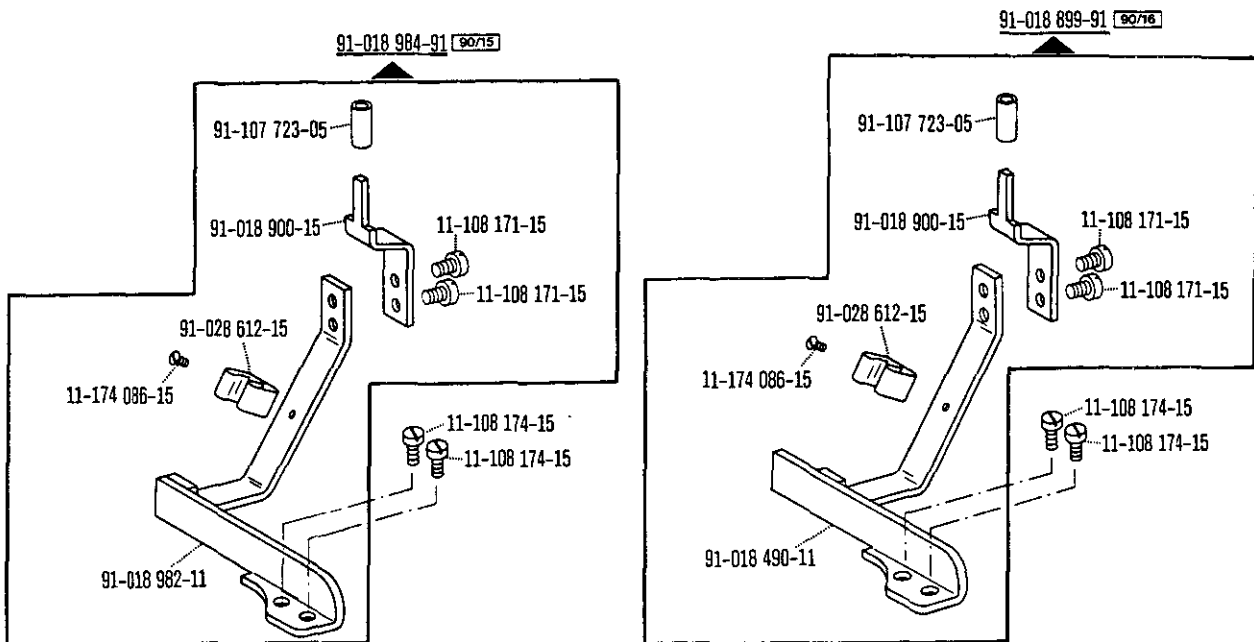

Knieschalter
 Knee switch
 Déclenchée par genouillère
 Interruptor de rodilla

zur - pour les Pfaff 145-900/56-913/04; 545-900/56-913/04
 for - para les

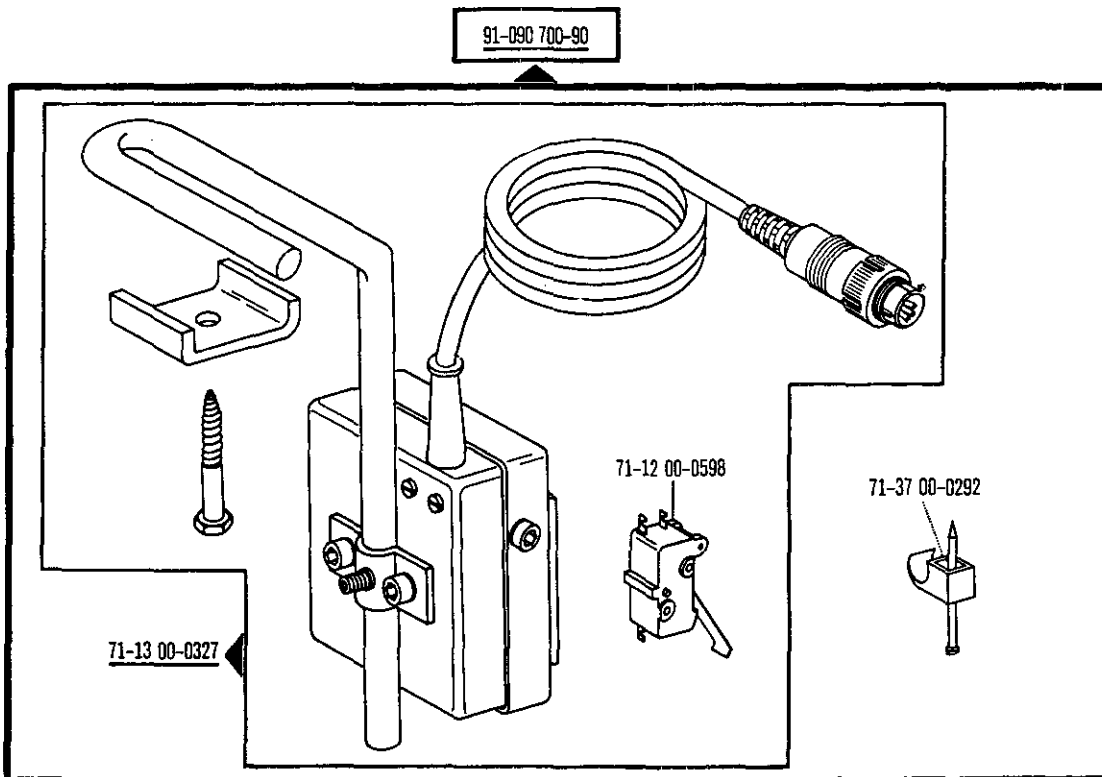



Keilriemenscheiben-Tabelle





Table of V-belt pulleys

Tableau des poulies à gorge en V

Tabla de poleas para correas en „V”

Nähgeschwindigkeit max. Stiche/min Maximum sewing speed in sp.m. Nombre de points max./mn Número máx. de puntadas por minuto	Motorzahl U/min Motor speed in r.p.m. Régime moteur en tours/mn Régimen del motor en r.p.m.	Frequenz Frequency Fréquence Frecuencia	Handrad-Durchmesser ¹⁾ in mm Balance wheel diameter ¹⁾ in mm Diamètre du volant ¹⁾ en mm Diámetro del volante ¹⁾ en mm	Keilriemenscheiben-Durchmesser ¹⁾ in mm V-belt pulley diameter ¹⁾ in mm Diamètre de la poulie à gorge ¹⁾ en mm Diámetro de la polea para correa en "V" ¹⁾ en mm	Teilenummer der Keilriemenscheibe Part number of V-belt pulley Numéro de pièce des poulies à gorge en V No de las piezas de poleas para correas en "V"
Pfaff 145					
1800	1400	50 Hz	75	95	16-437 080-55
1800	1700	60 Hz	75	80	16-437 050-55
2400	1400	50 Hz	75	132	16-437 901-55
2400	1700	60 Hz	75	106	16-437 100-55
Pfaff 545					
2100	2800	50 Hz	120	90	16-437 070-55
2100	3400	60 Hz	120	71	16-437 030-55
1600	2800	50 Hz	120	71	16-437 030-55
1600	1700	60 Hz	120	112	16-437 110-55
1500	1400	50 Hz	75	80	16-437 050-55
1500	1700	60 Hz	75	67	16-437 020-55
1500	1400	50 Hz	120	132	16-437 901-55
1500	1700	60 Hz	120	106	16-437 100-55
1500	2800	50 Hz	150	80	16-437 050-55
1500	1700	60 Hz	150	132	16-437 901-55
1200	1400	50 Hz	150	132	16-437 901-55
1200	1700	60 Hz	150	106	16-437 100-55
1000	1400	50 Hz	120	118	16-437 120-55
1000	1700	60 Hz	120	71	16-437 030-55
1000	1400	50 Hz	150	112	16-437 110-55
1000	1700	60 Hz	150	90	16-437 070-55
700	1400	50 Hz	150	75	16-437 040-55
700	1700	60 Hz	150	63	16-437 010-55

Bestellnummer für Behälter mit:
Ordering number for can containing:
Numéro de commande pour récipients avec:
Número de pedido para recipientes con:

	Liter Litre Litro	Kg	Techn. Weißöl White oil Huile blanche Aceite blanco	Sewtrol EL	Shell Tellus C 22	Shell-Retinax G
	0,09		91-129 569-91		91-129 138-91	
	0,25				91-129 916-91	
	1		91-129 452-91	91-129 941-91	91-129 917-91	
	5		91-129 456-91		91-129 919-91	
	10		91-129 541-91		91-129 920-91	
		0,5				280-1-120 243

No.	Seite Page Pages Página	No.	Seite Page Pages Página	No.	Seite Page Pages Página	No.	Seite Page Pages Página
11-032 465-15	89, 90, 91	11-108 288-15	17, 29	11-205 096-15	44	11-721 197-15	17, 21, 29, 32, 43, 71
11-039 291-15	62	11-108 864-25	58	11-205 222-15	44	11-721 482-15	20, 21, 30, 32, 52, 53
11-039 363-15	46, 74	11-130 176-15	54, 55	11-210 038-15	70, 78, 79, 87	11-724 290-55	75
11-105 113-15	70, 78, 79, 87	11-130 185-15	51	11-210 165-15	13, 23	12-005 154-15	51
11-106 933-15	45	11-130 191-15	51, 67, 81, 85, 92, 93, 94	11-210 168-15	14, 24	12-005 194-15	64, 68, 69, 82, 83
11-106 947-15	73, 77, 86	11-130 197-15	92, 93, 94	11-210 207-15	69, 83	12-005 195-15	45, 68, 69, 80, 82, 83, 84, 92, 93, 95
11-108 006-15	51	11-130 224-15	71	11-210 222-15	68, 69, 82, 83	12-024 151-15	14, 24, 34, 94
11-108 009-15	44	11-130 227-15	55	11-305 239-15	56, 57, 58	12-024 171-15	28, 44, 45, 54, 55, 56, 57, 58
11-108 093-15	46, 48, 72, 75	11-130 233-15	92, 93	11-310 436-15	68, 82	12-024 172-15	44, 54, 55
11-108 099-15	57, 70, 78, 79, 87	11-130 239-15	92, 93	11-310 463-15	80, 84	12-024 191-15	44, 45, 55, 63, 80, 84, 95
11-108 102-15	45	11-130 284-15	80, 84	11-314 946-15	44	12-024 192-15	55
11-108 117-15	57	11-130 293-15	66, 69, 71, 83, 94	11-315 917-05	35	12-024 223-15	56, 73, 77, 86
11-108 168-15	13, 23, 72, 73, 77, 86	11-130 299-15	80, 84	11-317 167-15	60	12-024 231-15	89, 90, 91
11-108 171-15	45, 57, 73, 77, 86, 102, 105	11-130 365-15	45, 88	11-317 949-15	57, 58	12-085 170-15	57, 58
11-108 173-05	75	11-130 371-15	56	11-317 971-15	60	12-090 150-05	95
11-108 174-15	47, 57, 66, 67, 70, 74, 78, 79, 81, 85, 87, 92, 102, 105	11-130 401-15	73, 77, 86	11-330 085-15	44	12-110 211-15	15, 25
11-108 177-15	39, 44	11-130 407-15	72	11-330 166-15	56, 57, 58	12-115 180-15	72
11-108 180-15	22, 31	11-130 452-15	22, 31	11-330 220-15	57, 58	12-160 193-25	14, 24, 34
11-108 189-15	44	11-130 907-15	51	11-330 955-15	52, 53	12-177 100-05	62
11-108 189-25	95	11-135 451-11-15	22, 31	11-330 958-15	49	12-177 142-05	46, 74
11-108 222-15	18, 27, 44, 49, 57, 58, 72, 73, 77, 86	11-172 094-25	58	11-340 292-15	64	12-305 084-15	58
11-108 225-15	14, 22, 24, 31, 34, 35, 39, 45, 57, 58	11-173 171-55	70, 71, 79	11-341 902-15	57, 58	12-305 114-15	94
11-108 228-15	14, 18, 27, 38, 39, 48, 57, 58, 73, 76, 77, 86	11-173 174-15	98, 99	11-450 403-15	98, 99	12-305 114-25	73, 77, 86
11-108 231-15	45	11-174 086-15	14, 24, 36, 102, 105	11-450 510-15	74, 76	12-305 144-15	19, 40, 57, 58, 61, 65, 95
11-108 240-15	57, 92	11-174 176-15	13, 23, 41	11-460 109-15	47, 70, 78, 79, 87, 96	12-305 174-15	66, 80, 84
11-108 246-15	57, 58	11-174 217-15	32	11-460 157-15	66, 67, 85	12-305 224-15	45, 46, 56, 74
11-108 250-15	28	11-174 232-15	59, 96	11-460 163-15	99, 100	12-305 264-15	89, 90, 91
11-108 285-15	59, 70, 80	11-174 287-15	54, 55	11-460 250-15	46, 95, 100	12-315 070-25	37
		11-174 293-15	28, 57, 58	11-460 403-15	64	12-315 090-25	36
		11-174 914-05	57, 58	11-460 406-15	59, 63, 64, 67, 81, 85, 96		
		11-178 166-15	14, 24				
		11-186 976-15	70, 78, 79, 87				

No.	Seite Page Pages Página	No.	Seite Page Pages Página	No.	Seite Page Pages Página	No.	Seite Page Pages Página
12-315 170-15	14, 24, 34	13-052 095-75	37	16-437 901-55	106	70-37 45-0002	70, 78, 79, 87
12-335 151-15	14, 24, 34	13-052 157-15	72	18-272 020-65	90	70-37 70-0006	66, 67, 84, 85
12-335 191-15	27, 62, 67, 81, 85, 95	13-052 250-15	19, 40, 61, 65	18-277 001-91	64, 67, 68, 69, 85	70-41 14-0162	75
12-341 090-15	13, 23, 48	13-052 340-15	52, 53, 56	18-277 003-91	90	70-41 37-0023	46, 76
12-341 150-15	20, 30, 45, 52, 53	13-052 481-15	52, 53	18-278 005-91	67, 85	70-44 14-0151	75, 76
12-500 121-45	46	13-052 983-15	13, 23	18-279 010-91	67, 81, 85, 94	71-11 00-0133	46
12-500 151-45	66, 67, 81, 85	13-060 400-05	22, 31	18-372 001-61	64, 67, 85, 94	71-11 00-0178	100
12-500 170-45	45	13-064 383-05	18, 27, 38	18-372 003-61	90	71-11 00-0183	98, 99
12-500 190-45	69, 83	13-065 199-05	17, 29, 36	18-372 004-61	89, 90, 91,	71-11 00-0185	99
12-500 210-45	46, 74	13-065 259-05	22, 31	18-373 011-61	67, 68, 69, 85	71-11 00-0186	98, 99
12-501 190-45	44, 54, 55, 66, 80, 84, 94	13-240 201-05	47	18-373 021-61	90	71-11 00-0213	98, 99
12-505 190-45	36	13-250 436-05	95	18-378 001-61	64, 67, 68, 69, 80, 81, 82, 83, 84, 85, 92, 93, 94	71-11 00-0220	46
12-510 110-45	58	14-017 121-91	59	18-378 002-61	67, 81, 85, 94	71-11 00-0221	46
12-515 250-05	15, 25	14-650 104-05	15, 25	24 132-2.204-4	84, 88	71-11 00-0232	66, 101
12-523 190-45	95	14-731 911-05	95	24 140-2.206-4	66, 67, 78, 85, 87	71-11 00-0246	98, 99
12-610 190-45	64	14-755 043-01	68, 69, 82, 83	24 140-2.208-4	78, 79, 87	71-11 00-0262	98
12-610 210-45	13, 23, 41	15-032 001-45	64, 67, 68, 69, 81, 82, 83, 85, 92, 93, 94	24 140-2.306-4	78, 87	71-12 00-0025	57, 70, 78, 79, 87
12-610 230-45	56	15-032 002-45	89, 90, 91	24 140-2.307-4	74, 79	71-12 00-0431	45
12-640 090-55	49	16-041 055-21	71	25 134-8.004-0	66, 67, 81, 85, 90, 94	71-12 00-0575	66, 101
12-640 130-55	32, 33, 48, 54, 55	16-042 050-15	45	25 134-8.005-0	89, 90, 91, 94	71-12 00-0576	66, 101
12-640 150-55	32, 33, 56, 59, 63, 64, 96	16-049 040-11	63	40-754 701-00	97	71-12 00-0577	62
12-640 170-55	27, 37, 38, 45, 56, 57, 58, 71, 97	16-437 010-55	106	70-754 701-00	97	71-12 00-0598	88, 105
12-640 200-55	48	16-437 020-55	106	70-15 16-0110	76	71-13 00-0322	88
12-640 250-55	48	16-437 030-55	106	70-15 21-5001	75, 76	71-13 00-0327	105
12-642 170-45	19, 40, 61, 65	16-437 040-55	106	70-15 21-5403	46	71-14 00-0003	47, 103
12-650 008-55	56	16-437 050-55	106	70-15 31-0001	46, 76	71-14 00-0006	102
12-651 006-51	95	16-437 070-55	106	70-16 31-5111	98, 100	71-14 00-0009	104
13-030 088-05	44	16-437 080-55	106	70-16 32-0101	46, 99, 100	71-14 00-0010	104
13-030 341-05	97	16-437 100-55	106	70-37 15-0002	76	71-14 00-0011	104
13-033 280-05	56	16-437 110-55	106	70-37 15-0003	70, 78, 79, 87	71-14 00-0014	104
13-033 400-05	95	16-437 120-55	106	70-37 24-0002	45	71-14 00-0025	104
						71-14 00-0032	104
						71-15 00-0135	46

No.	Seite Page Pages Página	No.	Seite Page Pages Página	No.	Seite Page Pages Página	No.	Seite Page Pages Página
71-1600-0065	66, 101	71-23 00-0118	47, 57, 102, 103	71-59 00-0237	66, 101	91-000 068-15	22, 31
71-1600-0112	47, 66, 101, 102, 103	71-25 00-0147	46	71-59 00-0242	62	91-000 070-15	17, 20, 29, 30, 43, 52, 53
71-1600-0118	66, 67, 85, 101	71-25 00-0160	46	71-59 00-0259	101	91-000 072-15	14, 24
71-1600-0137	57	71-37 00-0108	99, 100	71-59 00-0264	62	91-000 072-25	14
71-1600-0140	70, 74, 78, 79, 87	71-37 00-0132	58	71-59 00-0265	62	91-000 073-15	13, 14, 20, 23, 24, 30, 38
71-1600-0141	70, 71, 79	71-37 00-0133	57, 70, 78, 79, 87	71-59 00-0268	101	91-000 078-15	19, 40, 61 65
71-1600-0142	70, 74, 79	71-37 00-0158	71, 74, 76	71-59 00-0331	62	91-000 082-15	13, 16, 21, 23, 26, 30
71-1600-0143	70, 78, 79, 87	71-37 00-0167	70, 79	71-59 00-0332	62	91-000 082-25	95
71-1600-0147	47	71-37 00-0173	70, 78, 79, 87	71-59 00-0333	62	91-000 083-15	14, 24
71-1600-0149	46	71-37 00-0174	74, 76, 98, 99	71-59 00-0334	62	91-000 085-25	36
71-1600-0150	46	71-37 00-0175	98, 99	71-59 00-0335	62	91-000 086-15	15, 25
71-1600-0168	47	71-37 00-0183	45	71-59 00-0336	62	91-000 089-15	13, 18, 23, 27
71-1600-0198	78, 87	71-37 00-0186	45, 47	71-59 00-0351	104	91-000 091-15	37
71-1600-0199	78, 87	71-37 00-0201	47	71-59 00-0352	104	91-000 150-15	13, 17, 18, 21, 23, 27, 29, 32, 38, 41, 42, 50
71-1600-0203	71	71-37 00-0210	71	71-59 00-0368	62	91-000 152-15	14, 17, 18, 24, 27, 29, 38, 72, 73, 77, 86
71-1600-0208	84, 88	71-37 00-0223	78, 87	71-63 00-0021	46	91-000 172-25	16, 26
71-1600-0277	78, 87	71-37 00-0260	74, 98, 99	71-63 00-0046	75	91-000 186-15	59, 63, 64, 96
71-1600-0278	78, 87	71-37 00-0292	70, 99, 100, 105	71-63 00-0049	78, 87	91-000 225-15	33
71-17 00-0048	71	71-37 00-0309	78, 87, 88	71-63 00-0056	46, 75, 76	91-000 237-15	15, 25, 95
71-17 00-0051	45	71-37 00-0315	70, 78, 79, 87	71-63 00-0058	46	91-000 237-25	95
71-17 00-0052	45	71-37 00-0317	70, 78, 79, 87	91-000 011-15	35, 39	91-000 239-15	16, 26, 41
71-17 00-0056	44	71-37 00-0332	98, 99	91-000 019-15	15, 25	91-000 243-15	13, 15, 16, 23, 25, 26, 41
71-17 00-0131	57, 58	71-37 00-0333	98, 99	91-000 029-15	19, 40, 61, 65	91-000 263-15	28
71-1900-0040	46	71-44 00-0026	76	91-000 034-15	15, 25, 34, 36	91-000 278-15	15, 25, 34, 42, 50
71-1900-0068	46	71-44 00-0131	46	91-000 048-15	14, 24	91-000 290-15	22, 31
71-1900-0080	76	71-44 00-0135	46	91-000 050-15	17, 29	91-000 321-15	19, 28, 29, 40
71-1900-0188	75	71-44 00-0163	75	91-000 058-15	21, 32	91-000 323-15	17, 29
71-2100-0111	45	71-54 00 0051	46	91-000 059-15	18, 27, 38	91-000 335-15	16, 26
71-2100-0125	58	71-54 00-0066	46, 76	91-000 062-15	14, 24		
71-2100-0143	57	71-55 00-0033	46	91-000 062-25	95		
71-2100-0211	75	71-59 00-0089	62, 63	91-000 063-15	37, 48, 49		
71-2100-0213	75	71-59 00-0098	62, 63	91-000 064-15	18, 27, 28, 35, 72		

No.	Seite Page Pages Página	No.	Seite Page Pages Página	No.	Seite Page Pages Página	No.	Seite Page Pages Página
91-000 338-15	36	91-000 547-15	37	91-001 588-15	37	91-007 687-05	14, 24
91-000 340-15	19, 28, 37, 40, 72	91-000 560-15	22, 31, 35	91-001 593-15	18, 27, 38	91-008 003-05	17, 29
91-000 341-15	48	91-000 568-15	15, 25	91-001 601-15	72	91-008 004-05	17, 29
91-000 359-15	95	91-000 636-15	34	91-001 734-15	72, 73, 77, 86	91-008 005-05	17, 29
91-000 363-15	19, 28, 36	91-000 645-05	14, 24	91-001 758-05	14, 24, 29	91-008 007-05	41
91-000 363-25	95	91-000 660-15	18, 27	91-002 504-45	19, 40, 61, 65, 69, 83	91-008 008-92	13, 23, 41
91-000 364-25	95	91-000 666-05	16, 26, 41, 60	91-003 100-00	15, 25	91-008 009-05	13, 41
91-000 366-15	16, 26, 41, 60	91-000 668-15	29	91-004 005-05	16, 26, 41, 60	91-008 011-05	13, 23, 41
91-000 366-25	95	91-000 672-15	18, 27, 38	91-004 006-05	16, 26, 41, 60	91-008 021-11	15, 25
91-000 367-15	19, 28, 34, 48, 61, 65	91-000 680-15	17, 21, 29, 32, 33	91-004 170-45	97	91-008 028-05	37
91-000 382-15	29	91-000 687-15	18, 20, 27, 38, 43, 52, 53, 72	91-004 171-15	97	91-008 030-05	37
91-000 386-15	19, 28, 34	91-000 689-15	17, 21, 29, 32, 33, 43, 52, 53	91-004 172-05	97	91-008 031-05	37
91-000 390-15	20, 30, 41, 43, 51	91-000 699-15	20, 30, 43, 52, 53	91-004 173-15	97	91-008 034-05	37
91-000 405-15	17, 29	91-000 715-25	18, 27, 38	91-004 184-45	97	91-008 040-92	35
91-000 406-15	19, 40, 61, 65, 69, 83	91-000 737-05	95	91-004 186-15	22, 31	91-008 056-05	37
91-000 407-15	21, 30, 36	91-000 739-15	18, 27	91-005 005-05	95	91-008 057-05	37
91-000 412-25	16, 26, 41	91-000 741-15	17, 29	91-005 068-05	19, 28, 40	91-008 064-05	13, 23
91-000 422-25	21, 30, 36	91-000 783-15	22, 31	91-005 070-05	19, 28, 40	91-008 280-91	72
91-000 456-15	17, 29	91-000 785-15	20, 22, 30, 31, 33, 52, 53	91-005 125-05	95	91-008 317-05	15, 25
91-000 469-15	15, 25	91-000 790-15	30, 52, 53	91-005 564-45	95	91-008 318-05	15, 25
91-000 503-15	22, 31, 35, 37, 39	91-000 809-15	22, 31	91-005 567-25	95	91-008 440-91	35
91-000 505-15	20, 30, 52, 53	91-000 885-15	17, 29	91-005 568-25	95	91-008 469-01	35
91-000 510-15	14, 15, 17, 18, 24, 25, 27, 29, 33, 34, 35, 38, 39, 72, 73, 77, 86	91-000 928-15	20, 30, 41, 43, 51	91-005 569-25	95	91-008 470-05	35
91-000 511-15	17, 29	91-001 283-15	63, 64	91-005 604-05	17, 29	91-009 005-45	19, 40
91-000 522-15	18, 27	91-001 288-15	21, 32, 33	91-005 673-05	22, 31, 35, 39	91-009 009-05	34
91-000 524-05	16, 26	91-001 512-15	18, 27, 34, 35, 39	91-006 155-15	19, 40, 60, 61, 65, 69, 83	91-009 014-92	28
91-000 525-15	20, 30	91-001 513-15	19, 40, 61, 65	91-006 505-05	16, 26, 41, 60	91-009 148-05	13, 23, 41
91-000 526-15	37	91-001 522-25	16, 26, 41, 60	91-006 526-05	34	91-009 149-05	22, 31
91-000 529-15	20, 30, 41, 43, 51	91-001 533-25	95	91-006 623-45	19, 28, 40	91-009 302-45	19, 28
91-000 532-15	37	91-001 536-15	22, 31, 35, 39	91-006 759-05	18, 27, 38	91-009 308-25	21, 30
		91-001 538-15	19, 28, 40	91-006 783-05	13, 18, 23, 27, 38, 41	91-009 325-05	13
						91-009 328-91	16, 41

No.	Seite Page Pages Página	No.	Seite Page Pages Página	No.	Seite Page Pages Página	No.	Seite Page Pages Página
91-009 333-15	19, 28	91-009 602-05	72	91-010 016-05	17, 29	91-010 141-01	36
91-009 335-45	22, 31	91-009 603-45	18, 27	91-010 017-05	17, 29	91-010 146-92	22, 31
91-009 337-05	33	91-009 604-05	18, 27, 73, 77, 86	91-010 022-05	21, 32	91-010 157-01	20
91-009 338-92	33	91-009 605-05	18, 27, 38, 73, 77, 86	91-010 023-05	16, 41	91-010 158-05	20
91-009 339-15	33	91-009 606-05	18, 27, 72	91-010 026-21	16, 26	91-010 159-91	20
91-009 341-05	33	91-009 609-05	18, 27, 38	91-010 027-35	16, 26	91-010 161-05	20, 43, 51
91-009 342-05	33	91-009 610-91	18, 27, 38	91-010 028-35	16, 26	91-010 164-91	20, 43, 51
91-009 343-05	32, 33	91-009 612-15	18, 27, 38	91-010 031-92	35	91-010 165-91	20
91-009 344-05	33	91-009 616-05	18, 27, 73, 77, 86	91-010 041-05	42, 50	91-010 166-05	20, 43, 51
91-009 345-05	33	91-009 617-05	18, 27, 38, 73, 77, 86	91-010 042-05	42, 50	91-010 167-05	20, 43, 51
91-009 346-05	33	91-009 618-05	18, 27, 38, 73, 77, 86	91-010 043-05	42, 50	91-010 172-90	28
91-009 347-05	21, 39	91-009 621-92	17, 29	91-010 044-05	21, 32	91-010 177-25	97
91-009 351-91	33	91-009 622-92	17	91-010 056-05	20, 30, 43, 52, 53	91-010 178-05	20, 43, 51
91-009 359-91	22, 31	91-009 624-05	18, 27, 73, 77, 86	91-010 057-01	20, 43, 52	91-010 181-15	16, 26, 41, 60
91-009 362-91	20	91-009 633-92	18, 27, 72, 73, 77, 86	91-010 059-45	20	91-010 183-05	16, 41, 60
91-009 390-15	13, 23	91-009 636-91	18, 27, 72	91-010 061-24	21, 30	91-010 184-05	26
91-009 391-21	16, 26, 41	91-009 648-25	18, 27	91-010 062-92	42, 50	91-010 185-05	16, 26, 41, 60
91-009 408-05	32, 33	91-009 652-91	26	91-010 067-05	19, 28, 39, 47, 59	91-010 186-15	16, 26, 41, 60
91-009 424-91	97	91-009 690-91	18, 27	91-010 079-05	20	91-010 196-05	17, 29
91-009 431-90	20	91-009 702-02	27	91-010 087-05	20	91-010 204-15	19, 40, 61, 85
91-009 432-90	21, 32	91-009 831-01	44	91-010 088-05	20, 30, 43, 52, 53	91-010 211-05	22, 31
91-009 489-05	13, 23, 41	91-009 837-91	45	91-010 089-01	20	91-010 212-45	35
91-009 498-90	18, 27	91-009 838-15	45	91-010 103-05	20, 43, 52	91-010 221-05	22, 31
91-009 499-91	18, 27	91-009 844-45	45	91-010 104-05	14, 24	91-010 223-92	35
91-009 500-91	27	91-009 846-15	45	91-010 107-05	16, 26, 41, 60	91-010 360-05	14, 24
91-009 576-91	27	91-009 870-15	59, 70, 80	91-010 115-05	16, 26, 41, 60	91-010 361-05	21, 32, 39
91-009 577-90	73, 77, 86	91-009 871-15	63, 64	91-010 116-05	16, 26, 41, 60	91-010 538-05	73, 77, 86
91-009 586-91	60	91-009 872-15	63, 64	91-010 120-05	20, 30, 43, 52, 53	91-010 596-05	17, 18, 27, 29, 38
91-009 587-21	60	91-009 938-15	19, 28, 61, 65	91-010 121-90	21, 32	91-010 606-45	19, 28, 40, 61, 65
91-009 590-11	60	91-010 002-05	17, 29	91-010 126-92	22, 31, 35	91-010 610-91	14, 24
91-009 599-05	72, 73, 77, 86	91-010 009-05	14, 24	91-010 127-90	17, 29	91-010 617-45	28
91-009 602-02	18, 27	91-010 013-05	17, 29	91-010 133-90	19, 40	91-010 618-15	34

No.	Seite Page Pages Página	No.	Seite Page Pages Página	No.	Seite Page Pages Página	No.	Seite Page Pages Página
91-010 625-24	21, 30	91-010 752-15	15, 25	91-011 724-92	14, 24	91-013 086-12	57, 58
91-010 631-92	34	91-010 755-15	18, 27	91-011 725-45	14, 24	91-013 087-15	49
91-010 632-45	34	91-010 817-90	13, 23	91-011 727-05	14, 24	91-013 088-05	49
91-010 633-05	34	91-010 817-91	13, 23	91-011 729-92	14, 24	91-013 089-05	48
91-010 636-45	14, 24	91-010 819-25	13, 23	91-011 730-45	14, 24	91-013 090-05	56
91-010 646-91	14, 24	91-010 820-45	13, 23	91-011 731-05	14, 24	91-013 091-05	48
91-010 649-91	34	91-010 821-25	13, 23	91-011 732-05	14, 24	91-013 092-01	53
91-010 666-91	13	91-010 867-90	20, 30	91-011 734-05	14, 24	91-013 094-15	51
91-010 668-91	23	91-010 888-15	34	91-011 738-05	14, 24	91-013 095-45	56
91-010 676-15	34	91-010 893-05	20, 43	91-011 739-92	15, 25	91-013 096-12	54
91-010 680-45	39	91-010 894-05	20, 43	91-011 746-05	14, 24	91-013 098-91	54
91-010 681-91	38	91-010 895-91	20, 43	91-011 752-92	14, 24, 34	91-013 102-45	13, 23
91-010 682-25	38	91-010 896-91	20	91-011 754-05	16, 26	91-013 104-45	14, 24
91-010 684-25	39	91-010 937-05	26	91-011 755-05	13	91-013 106-45	14, 24
91-010 687-91	39	91-010 942-05	23	91-011 778-05	14, 24, 34	91-013 109-91	19, 28
91-010 689-05	37	91-011 264-05	20	91-011 783-91	17, 29	91-013 139-05	16, 26
91-010 694-93	36	91-011 431-91	37	91-011 929-15	34	91-013 152-41	49
91-010 695-14	36	91-011 432-45	37	91-012 072-05	33	91-013 153-05	32, 33
91-010 700-45	13, 23	91-011 434-45	38	91-012 407-15	19, 28, 48, 61, 65	91-013 154-02	53
91-010 703-92	13, 23, 41	91-011 435-05	38	91-012 492-25	27	91-013 154-05	53
91-010 704-15	22, 31	91-011 436-05	38	91-013 044-25	18	91-013 156-91	49
91-010 729-05	15, 25	91-011 437-02	38	91-013 073-90	33	91-013 157-91	51
91-010 730-15	15, 25	91-011 441-91	37	91-013 074-91	33	91-013 162-91	55
91-010 731-45	15, 25	91-011 442-05	37	91-013 075-05	33	91-013 174-12	55
91-010 732-05	15, 25	91-011 443-05	37	91-013 076-05	33	91-013 175-91	55
91-010 733-45	34	91-011 444-01	37	91-013 077-05	33	91-013 178-15	48
91-010 734-15	34	91-011 446-92	37	91-013 078-92	33	91-013 179-11	71
91-010 735-15	15, 25	91-011 447-25	37	91-013 079-15	49	91-013 184-05	57
91-010 736-15	34	91-011 454-91	39	91-013 080-15	48	91-013 184-92	57
91-010 737-45	34	91-011 455-05	17, 29	91-013 081-05	49	91-013 185-90	32
91-010 738-45	19, 28	91-011 497-91	34	91-013 082-11	56	91-013 186-91	32
91-010 739-45	34	91-011 718-92	34	91-013 084-11	49	91-013 187-05	32

No.	Seite Page Pages Página	No.	Seite Page Pages Página	No.	Seite Page Pages Página	No.	Seite Page Pages Página
91-013 188-05	32	91-018 155-15	92, 93	91-018 350-05	30, 41, 51	91-018 680-91	51
91-013 189-05	32	91-018 156-15	93	91-018 357-45	21, 32, 42, 50	91-018 674-91	52
91-013 190-92	32	91-018 157-15	57, 58	91-018 358-45	17, 29	91-018 675-45	52, 53
91-013 191-05	48	91-018 158-12	55	91-018 359-45	17, 29	91-018 677-01	52
91-013 192-15	48	91-018 159-92	57, 58	91-018 397-25	36	91-018 678-05	52
91-013 193-91	48	91-018 160-92	57, 58	91-018 399-25	36	91-018 679-05	52, 53
91-013 196-45	48	91-018 161-91	54	91-018 401-91	30	91-018 688-05	23
91-014 679-25	16, 26	91-018 162-12	54	91-018 402-45	30	91-018 689-91	23
91-014 680-91	16, 26	91-018 169-12	93	91-018 403-05	30, 52	91-018 792-12	54
91-014 709-05	17, 29	91-018 170-05	92, 93	91-018 404-05	30	91-018 793-91	51
91-014 710-01	17, 29	91-018 172-91	94	91-018 406-01	30	91-018 794-15	51
91-014 740-45	28	91-018 173-90	92, 93	91-018 407-05	30	91-018 885-15	51
91-014 786-15	28	91-018 190-15	92, 93	91-018 415-92	29	91-018 886-01	52
91-015 487-90	43, 52, 53	91-018 223-15	92	91-018 439-05	30, 51	91-018 888-24	42, 50
91-015 527-05	23	91-018 224-45	56	91-018 460-90	17, 29	91-018 889-24	42, 50
91-015 659-92	17, 29	91-018 225-11	56	91-018 467-90	27	91-018 891-45	59
91-015 664-05	22, 31	91-018 227-11	92	91-018 477-90	30, 52, 53	91-018 899-91	105
91-015 673-21	28	91-018 228-92	92	91-018 480-05	51	91-018 900-15	105
91-015 846-92	39	91-018 229-15	92	91-018 481-05	41	91-018 905-05	51
91-015 847-45	39	91-018 233-91	54	91-018 482-91	41	91-018 954-91	53
91-015 870-91	41	91-018 234-12	54	91-018 483-91	41	91-018 961-11	69, 83
91-017 530-91	28	91-018 235-91	55	91-018 484-05	41	91-018 964-11	69, 83
91-018 115-92	28	91-018 236-12	55	91-018 485-25	48	91-018 969-15	68, 72, 82
91-018 136-12	35	91-018 249-15	92	91-018 486-15	51	91-018 982-11	102, 105
91-018 137-05	50	91-018 273-90	73, 77, 86	91-018 488-92	29	91-018 983-11	102
91-018 138-05	50	91-018 286-91	55	91-018 489-11	102	91-018 984-91	105
91-018 146-91	51	91-018 339-05	30	91-018 490-11	102, 105	91-018 987-15	69, 83
91-018 147-05	51	91-018 340-91	30	91-018 492-11	102	91-019 532-91	13
91-018 148-01	53	91-018 341-91	30, 51	91-018 600-01	30, 52, 53	91-019 619-90	21, 32
91-018 150-05	32	91-018 342-05	30, 41, 51	91-018 638-92	57, 58	91-019 623-90	71
91-018 151-05	32	91-018 344-05	30, 51	91-018 639-91	57, 58	91-019 651-92	15
91-018 154-15	93	91-018 346-01	30, 41	91-018 662-45	31	91-019 656-05	15, 25
		91-018 348-91	30, 41				
		91-018 349-05	30, 41				

No.	Seite Page Pages Página	No.	Seite Page Pages Página	No.	Seite Page Pages Página	No.	Seite Page Pages Página
91-019 657-05	15, 25	91-027 371-12	59, 96	91-050 339-12	15, 25	91-069 043-15	13, 23, 41
91-019 660-15	15, 25	91-027 373-92	59, 96	91-050 855-45	95	91-069 056-05	17, 29
91-019 661-15	25	91-027 375-15	59, 96	91-053 332-41	95	91-069 130-05	71
91-019 662-15	15, 25	91-028 036-25	36	91-053 332-91	95	91-069 468-15	60
91-019 663-45	19, 28	91-028 612-15	47, 102, 105	91-053 347-21	95	91-069 495-05	56
91-019 664-15	15, 25	91-029 007-91	97	91-055 203-91	15, 25	91-069 809-45	88
91-019 665-15	15, 25	91-029 033-45	97	91-055 204-15	15, 25	91-070 171-90	33
91-019 676-05	13, 18, 23, 27, 35, 38, 41	91-029 394-01	97	91-055 205-05	15, 25	91-080 233-05	59, 63, 64, 96
91-019 677-91	28	91-029 450-15	97	91-056 183-91	95	91-082 231-90	90
91-019 694-91	38	91-029 520-05	42, 48	91-056 184-45	95	91-082 878-15	68, 69, 82, 83
91-019 735-15	48	91-029 692-45	59, 96	91-056 185-91	95	91-083 761-91	73, 77, 86
91-018 793-91	51	91-029 946-91	97	91-056 186-45	95	91-083 762-45	73, 77, 86
91-019 853-12	21, 32, 33	91-030 246-15	28, 34	91-056 187-45	95	91-083 763-11	73, 77, 86
91-019 862-01	20, 43, 52, 53	91-031 009-45	63, 64	91-056 188-45	95	91-083 764-11	73, 77, 86
91-019 891-05	43, 51	91-031 409-12	63, 64	91-056 189-05	95	91-083 765-15	73, 77, 86
91-020 353-91	44	91-031 411-90	96	91-056 190-15	95	91-083 766-15	73, 77, 86
91-020 391-92	50	91-031 458-51	80, 84	91-056 192-25	95	91-083 789-05	73, 77, 86
91-020 715-91	17, 29	91-031 459-15	68, 69, 82, 83	91-056 193-25	95	91-084 100-91	13, 23
91-023 505-25	16, 26	91-031 888-15	63	91-056 356-15	95	91-084 115-05	13, 23
91-025 054-45	96	91-032 805-91	97	91-056 578-91	95	91-084 116-15	13, 23
91-025 055-15	96	91-032 806-45	97	91-056 579-11	95	91-084 134-90	13, 23
91-025 060-92	59, 63, 64, 96	91-032 807-91	97	91-056 760-05	95	91-084 301-45	72
91-025 075-45	59, 96	91-032 808-45	97	91-061 005-05	34	91-084 302-05	72
91-025 164-05	19, 40, 61, 65	91-032 809-45	97	91-061 180-92	39	91-084 303-05	72
91-025 165-45	19, 40, 61, 65	91-033 073-90	91	91-063 049-05	37	91-084 304-15	72
91-025 169-92	59, 63, 64, 96	91-040 621-91	95	91-063 071-15	39	91-084 305-15	72
91-025 170-15	59, 96	91-040 618-45	95	91-063 073-91	39	91-084 306-05	72
91-025 184-15	19, 40, 61, 65	91-040 623-25	95	91-063 118-05	37	91-084 307-05	72
91-025 637-15	13, 23	91-041 063-25	95	91-064 095-92	39	91-084 308-15	72
91-027 362-91	19, 40, 61, 65	91-041 085-91	95	91-064 583-05	37	91-084 309-15	72
91-027 363-45	19, 40, 61, 65	91-046 097-25	95	91-067 020-05	17, 29	91-084 311-15	72
91-027 370-05	59, 96	91-050 248-91	44, 54, 55	91-069 037-15	32, 33	91-084 314-25	72, 73, 77, 86

No.	Seite Page Pages Página	No.	Seite Page Pages Página	No.	Seite Page Pages Página	No.	Seite Page Pages Página
91-086 176-45	89, 90, 91	91-095 647-91	99	91-099 392-91	79	91-107 643-91	49
91-090 277-05	75	91-095 648-91	99	91-099 613-91	46	91-107 647-91	52, 53
91-090 291-91	71	91-095 651-91	99	91-099 766-91	99	91-107 648-45	52, 53
91-090 292-45	71	91-095 675-91	76	91-099 811-05	71	91-107 657-05	57, 58
91-090 583-91	98	91-095 676-91	76	91-099 904-45	58	91-107 658-11	56
91-090 584-91	98	91-095 784-45	57	91-100 015-15	36	91-107 661-12	56
91-090 585-91	98	91-095 787-05	57	91-100 044-15	19, 28, 29, 40	91-107 663-05	56
91-090 586-91	98	91-095 788-45	57	91-100 270-15	70, 78, 79, 87	91-107 664-90	59
91-090 700-90	105	91-095 808-45	57	91-100 271-15	14, 24	91-107 665-15	59
91-090 831-91	99	91-095 809-45	57	91-100 341-15	17, 21, 29, 32, 33	91-107 666-15	59, 70, 80
91-090 832-91	99	91-095 829-91	66, 67, 85	91-100 342-15	17, 21, 29, 32, 33	91-107 669-45	59, 96
91-090 850-45	74	91-095 837-91	84	91-100 373-15	71, 80, 84	91-107 689-15	57
91-090 855-01	74	91-095 850-91	58	91-101 775-05	97	91-107 694-91	47, 59
91-090 859-05	75	91-095 856-91	57, 103	91-102 007-92	27, 38, 73, 77, 86	91-107 695-91	59
91-090 922-91	75	91-095 982-91	98	91-102 011-05	31, 35	91-107 696-12	59
91-091 585-91	78, 87	91-095 983-91	98	91-102 019-92	31, 39	91-107 723-05	105
91-091 587-91	78, 87	91-095 984-91	98	91-102 022-90	27	91-107 724-15	54, 55
91-091 688-91	75	91-095 985-91	98	91-102 028-25	27	91-107 736-91	57
91-091 770-05	75	91-095 997-91	98	91-102 033-05	27, 38, 73, 77, 86	91-107 738-05	56
91-091 834-91	88	91-096 178-91	100	91-102 035-91	31, 35	91-107 746-12	54
91-091 861-91	74	91-096 181-91	100	91-102 210-92	29	91-107 748-15	54, 55
91-095 103-91	100	91-096 183-91	100	91-102 216-91	29	91-107 757-01	52
91-095 140-91	46	91-096 560-91	57	91-105 447-15	16, 26, 41, 60	91-107 774-91	58
91-095 141-91	46	91-096 623-91	70, 79	91-107 204-15	57, 58	91-107 776-05	57, 58
91-095 143-91	46	91-096 747-91	79	91-107 249-45	73, 77, 86	91-107 777-12	57, 58
91-095 145-01	47	91-096 925-91	44	91-107 615-45	59	91-107 877-91	71
91-095 148-91	45	91-097 068-91	100	91-107 623-92	48, 61, 65	91-107 879-15	71
91-095 150-91	47	91-097 074-47	97	91-107 624-45	49	91-107 880-15	71
91-095 170-91	46	91-097 149-15	66, 67, 85	91-107 627-25	37	91-107 881-11	71
91-095 362-91	79	91-097 902-45	76	91-107 628-15	48	91-107 886-15	73, 77, 86
91-095 368-91	47	91-098 477-91	100	91-107 629-05	48	91-107 888-45	70, 78, 79, 87
91-095 645-91	99	91-098 888-45	98, 99	91-107 637-15	48, 49	91-107 889-45	70, 78, 79, 87

No.	Seite Page Pages Página	No.	Seite Page Pages Página	No.	Seite Page Pages Página	No.	Seite Page Pages Página
91-107 890-05	70, 78, 79, 87	91-113 062-05	42	91-113 414-91	43, 51	91-140 062-25	73, 77, 86
91-107 891-15	70, 78, 79, 87	91-113 063-05	47	91-113 453-91	44	91-140 068-45	48
91-107 892-15	70, 78, 79, 87	91-113 064-05	35	91-113 454-91	45	91-140 259-05	22, 31
91-107 893-45	70, 78, 79, 87	91-113 072-01	43, 52, 53	91-113 466-15	45	91-140 261-05	35, 39
91-107 923-91	54	91-113 073-05	43, 52, 53	91-113 467-15	45	91-140 286-05	51
91-107 924-12	54	91-113 075-05	20, 30, 43, 52, 53	91-113 468-15	63	91-140 287-91	51
91-107 925-15	55	91-113 077-05	43, 52, 53	91-113 469-15	63	91-140 291-01	51
91-107 926-05	55	91-113 083-12	44	91-113 478-11	63	91-140 403-91	18, 27, 73, 77, 86
91-107 927-15	55	91-113 087-05	54, 55	91-113 480-91	51	91-140 404-91	18, 27, 38, 73, 77, 86
91-107 928-91	55	91-113 091-15	44	91-114 310-15	80, 84	91-140 405-91	27, 38, 73, 77, 86
91-107 930-91	55	91-113 094-14	44	91-114 351-15	80, 84	91-140 425-45	18, 27
91-107 931-12	55	91-113 097-91	44	91-118 067-15	21, 30	91-140 501-91	80, 84
91-107 947-91	55	91-113 102-05	44	91-118 308-05	43, 51	91-140 648-01	51
91-108 001-91	14, 24	91-113 103-15	44	91-118 416-15	57	91-140 650-91	51
91-108 002-91	36	91-113 105-91	43	91-118 613-15	66, 94	91-140 651-05	51
91-108 009-05	14, 24, 34	91-113 106-45	43	91-119 025-25	16, 26	91-167 553-11	57, 58
91-108 010-15	14, 24, 34	91-113 108-12	44	91-125 932-15	64	91-167 559-05	57, 58
91-108 015-02	35	91-113 115-05	45	91-125 933-05	64	91-167 560-05	56, 57, 58
91-108 021-92	25	91-113 117-15	44	91-129 138-91	107	91-167 636-05	57, 58
91-108 527-91	14, 24	91-113 118-15	44	91-129 452-91	107	91-168 415-15	57, 58
91-108 528-91	38	91-113 125-91	43, 52, 53	91-129 456-91	107	91-168 906-45	57, 58
91-108 599-15	44	91-113 129-45	22, 31, 39, 42	91-129 541-91	107	91-168 907-05	57, 58
91-108 600-15	44	91-113 144-15	42, 48	91-129 569-91	107	91-168 909-15	57, 58
91-108 602-91	44	91-113 145-55	47	91-129 916-91	107	91-168 910-05	57, 58
91-113 006-12	44	91-113 152-45	42	91-129 917-91	107	91-168 913-05	56
91-113 011-15	15, 25	91-113 157-15	45	91-129 919-91	107	91-168 922-15	56
91-113 012-05	44, 49	91-113 160-91	97	91-129 920-91	107	91-168 923-05	56
91-113 014-05	44, 49	91-113 161-45	97	91-129 941-91	107	91-168 927-15	56
91-113 024-92	52, 53	91-113 190-91	43	91-130 865-05	80, 84	91-168 932-15	57
91-113 030-25	16, 26	91-113 191-01	43	91-130 886-05	80, 84	91-168 934-05	57, 58
91-113 042-92	19, 40	91-113 192-91	43	91-140 060-25	73, 77, 86	91-168 934-92	57, 58
91-113 046-91	47	91-113 193-05	43	91-140 061-15	73, 77, 86	91-168 945-05	56
91-113 060-45	47						
91-113 061-05	42						

No.	Seite Page Pages Página	No.	Seite Page Pages Página	No.	Seite Page Pages Página	No.	Seite Page Pages Página
91-169 132-15	14, 24	91-712 488-92	24	99-134 373-91	80, 84		
91-169 137-05	73, 77, 86	91-715 436-92	36	99-134 437-91	66		
91-169 582-05	56	93-513 120-91	59, 63, 64, 96	99-134 452-91	67, 81, 85		
91-170 783-91	70, 79	93-513 121-11	59, 63, 64, 96	99-134 498-91	92, 93		
91-171 462-90	89	93-513 124-05	59, 63, 64, 96	99-134 569-75	88		
91-175 023-05	32, 33	95-627 480-15	64, 80, 84	99-134 797-91	69, 83		
91-175 126-05	32	97-30 117-345	97	99-135 061-91	68, 82		
91-175 514-91	67	99-098 072-91	66, 101	99-135 062-91	69, 83		
91-175 515-45	67, 81, 85	99-115 231-91	83, 90	99-135 188-85	73, 77, 86		
91-175 536-15	68, 69, 82, 83	91-115 300-91	83, 90	99-135 350-91	67, 85		
91-175 537-11	68, 69, 82, 83	99-115 301-05	89, 90, 91	280-1-120 243	107		
91-175 581-91	68, 82	99-115 505-91	64, 68, 69				
91-175 586-91	69, 83	99-133 042-91	94				
91-176 031-91	81	99-133 126-91	94				
91-176 051-91	85	99-133 129-01	66				
91-492 330-14	36	99-133 130-01	94				
91-700 029-15	42, 48	99-133 506-91	64				
91-700 153-15	17, 29	99-133 574-91	81				
91-700 335-35	45	99-133 360-45	39, 30, 91				
91-700 388-15	16, 26	99-133 752-01	67, 81, 85, 94				
91-700 510-15	33, 57, 58	99-133 753-91	92, 93				
91-700 680-15	32	99-133 905-91	92, 93				
91-700 687-15	18, 27, 38, 73, 77, 86	99-133 946-91	68, 82				
91-700 689-15	20, 30, 32, 50, 52, 53, 56, 59, 92, 93	99-133 968-91	92, 93				
91-700 868-15	47	99-134 008-91	66, 67, 81, 84, 85				
91-700 961-15	18, 27, 32, 38	99-134 043-91	92, 93				
91-700 962-15	32	99-134 089-05	13, 23				
91-700 997-15	44	99-134 093-05	13, 23				
91-701 319-25	16, 26	99-134 195-91	91				
91-710 484-92	14, 24	99-134 299-91	67, 85				
91-710 650-92	14, 24	99-134 369-91	67, 85				
		99-134 370-91	66				